



**HERITAGE RANCH COMMUNITY SERVICES DISTRICT
BOARD OF DIRECTORS REGULAR MEETING MINUTES**

October 19, 2023

1. 4:00 PM OPEN SESSION / CALL TO ORDER / FLAG SALUTE

President Barker called the meeting to order at 4:00 pm and led the flag salute.

2. ROLL CALL

Secretary Gelos called the role.

Directors present: Bill Barker, Dan Burgess, Michael Camou, Devin Capps.

Directors absent: Masen Yaffee.

Staff present: General Manager, Scott Duffield, District Engineer, Doug Groshart, Operations Manager, Mike Wilcox and District Counsel, Josh George.

3. PUBLIC COMMENT ON MATTERS NOT ON THE AGENDA

There were no public comments.

4. CONSENT ITEMS

a. Meeting Minutes: Receive/approve minutes of regular meeting of September 21, 2023.

b. Warrant Register: Receive/approve September 2023 warrants.

c. Treasurer's Report: Receive/file September 2023 Report.

d. Treasurer's Report: Receive/file 3rd Quarter 2023 Report.

e. Fiscal Report: Receive/file September 2023 status report.

f. Office Report: Receive/file September 2023 report.

g. District Engineer Report: Receive/file October 2023 report.

h. Operations Manager Report: Receive/file October 2023 report.

There were no public comments.

Director Burgess made a motion to approve all items as presented. Director Camou seconded the motion. The motion passed by the following roll call vote:

Ayes: Barker, Burgess, Camou, Capps

Absent: Yaffee

5. BUSINESS ITEMS

- a. **Request to approve a proposal from Tuckfield & Associates to perform a sewer rate study and to provide associated financial support in an initial amount of \$18,800.**

There were no public comments.

Manager Duffield provided a brief summary of the item and answered any questions the board had.

Director Capps made a motion to approve staff recommendation. Director Burgess seconded the motion. The motion passed by the following voice vote:

Ayes: Barker, Burgess, Camou, Capps

Absent: Yaffee

- b. **Discussion and direction regarding procedures for cancelation of regular Board meetings.**

There were no public comments.

Manager Duffield provided a brief summary of the item and answered any questions the board had.

The Directors requested more notice and explanation prior to a meeting being canceled.

- c. **Discussion and direction regarding the employee grievance procedures outlined in the Memorandum of Understanding between Heritage Ranch Community Services Employees Association and Heritage Ranch Community Services District.**

There were no public comments.

Manager Duffield provided a brief summary of the item and answered any questions the board had.

- d. **Discussion and direction regarding disinfection byproducts.**

There were no public comments.

Manager Duffield provided a brief summary of the item and answered any questions the board had.

6. GENERAL MANAGER REPORT

There were no public comments.

Report was received and filed.

7. FUTURE AGENDA ITEMS

There were no public comments.

The Board determined to add the following to a future agenda:

- Legal Counsel RFP – tbd

8. ADJOURNMENT

On a motion by Director Burgess and seconded by Director Capps the meeting adjourned at 5:25 pm to the next scheduled meeting on Thursday, November 16, 2023.

APPROVED:

ATTEST:

Bill Barker, President
Board of Directors

Kristen Gelos, Secretary
Board of Directors

**HERITAGE RANCH COMMUNITY SERVICES DISTRICT
WARRANT REGISTER
OCTOBER 2023**

DATE	NAME OF PAYEE	ITEM AMOUNT	WARRANT AMOUNT
10/3/2023	CALPERS HEALTH BENEFITS EMPLOYEE PAID HEALTH BENEFIT	668.33	
	EMPLOYEE PAID HEALTH BENEFIT	668.33	\$ 1,336.66
10/3/2023	CALPERS HEALTH BENEFITS CALPERS HEALTH BENEFITS	15,419.76	\$ 15,419.76
10/6/2023	R. ARNOLD NET PAYROLL	2,882.89	\$ 2,882.89
10/6/2023	M. HUMPHREY NET PAYROLL	2,266.98	\$ 2,266.98
10/6/2023	B. VOGEL NET PAYROLL	2,570.75	\$ 2,570.75
10/6/2023	T. SHOGREN NET PAYROLL	2,344.47	\$ 2,344.47
10/6/2023	K. GELOS NET PAYROLL	2,772.81	\$ 2,772.81
10/6/2023	D. BURGESS NET PAYROLL	92.35	\$ 92.35
10/6/2023	B. BARKER NET PAYROLL	92.35	\$ 92.35
10/6/2023	S. DUFFIELD NET PAYROLL	3,451.94	\$ 3,451.94
10/6/2023	D. CAPPS NET PAYROLL	92.35	\$ 92.35
10/6/2023	M. WILCOX NET PAYROLL	2,392.11	\$ 2,392.11
10/6/2023	D. GROSHART NET PAYROLL	4,500.06	\$ 4,500.06
10/6/2023	M. CAMOU NET PAYROLL	92.35	\$ 92.35

**HERITAGE RANCH COMMUNITY SERVICES DISTRICT
WARRANT REGISTER
OCTOBER 2023**

DATE	NAME OF PAYEE	ITEM AMOUNT	WARRANT AMOUNT
10/6/2023	M. YAFFEE NET PAYROLL	92.35	\$ 92.35
10/6/2023	INTERNAL REVENUE SERVICE FEDERAL WITHHOLDING TAXES FICA WITHIHOLDING MEDICARE	2,679.22 62.00 1,010.86	\$ 3,752.08
10/6/2023	EMPLOYMENT DEVELOPMENT DEPARTM SDI STATE WITHHOLDING	309.22 1,111.01	\$ 1,420.23
10/6/2023	CALPERS RETIREMENT SYSTEM CALPERS UNIFORM ALLOWANCE PERS-IRC 457 CONTRIBUTIONS PERS RETIREMENT PERS RETIREMENT TIER 2 PERS RETIREMENT PEPRA PERS SERVICE CREDIT PURCHASE SURVIVOR BENEFIT	10.47 2,383.50 1,628.91 1,886.11 2,481.75 981.47 7.44	\$ 9,379.65
10/9/2023	PG&E ELECTRICITY	6,720.32	\$ 6,720.32
10/10/2023	GREAT WESTERN ALARM ALARM / ANSWERING SERVICE	313.32	\$ 313.32
10/10/2023	ADAMSKI, MOROSKI, MADDEN, CUMB LEGAL & ATTORNEY	2,350.00	\$ 2,350.00
10/10/2023	BLAKES INC SUPPLIES	50.01	\$ 50.01
10/10/2023	BRENNTAG PACIFIC, INC CHEMICALS CHEMICALS	3,602.05 844.90	\$ 4,446.95
10/10/2023	TYLER TECHNOLOGIES PROFESSIONAL SERVICES	22.50	\$ 22.50
10/10/2023	FGL ENVIRONMENTAL LAB TESTING	152.00	\$ 152.00

**HERITAGE RANCH COMMUNITY SERVICES DISTRICT
WARRANT REGISTER
OCTOBER 2023**

DATE	NAME OF PAYEE	ITEM AMOUNT	WARRANT AMOUNT
10/10/2023	J.H. SMITH CONSULTING PROFESSIONAL SERVICES	404.00	\$ 404.00
10/10/2023	RENTAL DEPOT EQUIPMENT RENT/LEASE	1,436.40	\$ 1,436.40
10/10/2023	FLUID RESOURCE MANAGEMENT PROFESSIONAL SERVICES	1,445.00	\$ 1,445.00
10/10/2023	PASO ROBLES FORD VEHICLES	170.00	\$ 170.00
10/10/2023	ABALONE COAST ANALYTICAL, INC. LAB TESTING	3,345.00	\$ 3,345.00
10/10/2023	CORE & MAIN LP SM TOOLS & EQUIPMENT SUPPLIES	1,049.68 912.85	\$ 1,962.53
10/10/2023	RHYTHM DESIGN UNIFORMS FY 23/24	561.50	\$ 561.50
10/10/2023	BURT INDUSTRIAL SUPPLY SM TOOLS & EQUIPMENT GAC PROJECT GAC PROJECT SUPPLIES SM TOOLS & EQUIPMENT	(1,551.10) 100.02 344.79 20.66 1,468.66	\$ 383.03
10/10/2023	DATA PROSE LLC SEPTEMBER BILLING	1,392.39	\$ 1,392.39
10/10/2023	SCOTT DUFFIELD MEDICAL REIMBURSEMENT	849.02	\$ 849.02
10/10/2023	WESTERN EXTERMINATOR STRUCTURES & GROUNDS	110.90	\$ 110.90
10/10/2023	RIVAL TECHNOLOGY INC. PROFESSIONAL SERVICES COMPUTER/SOFTWARE	909.36 130.00	\$ 1,039.36

**HERITAGE RANCH COMMUNITY SERVICES DISTRICT
WARRANT REGISTER
OCTOBER 2023**

DATE	NAME OF PAYEE	ITEM AMOUNT	WARRANT AMOUNT
10/10/2023	MID-STATE REPAIR SERVICE		
	MAINTENANCE FIXED EQUIPMENT	494.25	
	MAINTENANCE FIXED EQUIPMENT	494.25	
	MAINTENANCE FIXED EQUIPMENT	451.88	
	MAINTENANCE FIXED EQUIPMENT	494.25	
	MAINTENANCE FIXED EQUIPMENT	452.76	
	MAINTENANCE FIXED EQUIPMENT	427.02	
	MAINTENANCE FIXED EQUIPMENT	427.02	
	MAINTENANCE FIXED EQUIPMENT	486.01	
	MAINTENANCE FIXED EQUIPMENT	491.95	
	MAINTENANCE FIXED EQUIPMENT	437.66	
	MAINTENANCE FIXED EQUIPMENT	427.02	
	MAINTENANCE FIXED EQUIPMENT	621.42	\$ 5,705.49
10/10/2023	MIKE WILCOX		
	MEDICAL REIMBURSEMENT	712.94	\$ 712.94
10/10/2023	TROY SHOGREN		
	MEDICAL REIMBURSEMENT	214.21	\$ 214.21
10/10/2023	JORANDA MARKETING, INC. / JAN- STRUCTURES & GROUNDS		
		274.60	\$ 274.60
10/10/2023	SPEEDY COASTAL MESSENGER, INC. LAB TESTING		
		465.00	\$ 465.00
10/10/2023	SPICE INTEGRATION SCADA PROJECT		
		7,078.34	\$ 7,078.34
10/10/2023	NORTH COUNTY SEPTIC SERVICE IN MAINTENANCE FIXED EQUIPMENT		
		795.00	\$ 795.00
10/10/2023	FRESNO PIPE & SUPPLY, INC GAC PROJECT		
		1,872.11	\$ 1,872.11
10/10/2023	SIGN HERE SUPPLIES		
		159.80	\$ 159.80
10/10/2023	MATT'S SMOG & CAR CARE INC VEHICLES		
		41.75	\$ 41.75
10/10/2023	CHARTER COMMUNICATIONS INTERNET		
		89.99	\$ 89.99

**HERITAGE RANCH COMMUNITY SERVICES DISTRICT
WARRANT REGISTER
OCTOBER 2023**

DATE	NAME OF PAYEE	ITEM AMOUNT	WARRANT AMOUNT
10/10/2023	O'REILLY MAINT. FIXED EQUIP.	253.60	\$ 253.60
10/10/2023	THE VINTNER GAC PROJECT	52.18	\$ 52.18
10/10/2023	PORTOLA HOTEL TRAIN/TRAVEL	697.64	\$ 697.64
10/10/2023	CSDA BOD TRAINING & TRAVEL	625.00	\$ 625.00
10/10/2023	LOWE'S MAINTENANCE FIXED EQUIPMENT	52.90	\$ 52.90
10/10/2023	RING CENTRAL TELEPHONE	298.33	\$ 298.33
10/10/2023	AMAZON MAINTENANCE FIXED EQUIPMENT	97.56	\$ 97.56
10/10/2023	HARBOR FREIGHT SMALL TOOLS & EQUIPMENT SMALL TOOLS & EQUIPMENT	402.35 149.95	\$ 552.30
10/10/2023	STARLINK INTERNET	250.00	\$ 250.00
10/10/2023	OFFICE DEPOT / OFFICE MAX OFFICE SUPPLIES	62.73	\$ 62.73
10/10/2023	MATT'S SMOG & CAR CARE INC VEHICLES VEHICLES	43.42 43.42	\$ 86.84
10/10/2023	O'REILLY AUTO PARTS VEHICLES VEHICLES	(22.00) 371.72	\$ 349.72
10/14/2023	PITNEY BOWES GLOBAL FINANCIAL POSTAGE	20.76	\$ 20.76

**HERITAGE RANCH COMMUNITY SERVICES DISTRICT
WARRANT REGISTER
OCTOBER 2023**

DATE	NAME OF PAYEE	ITEM AMOUNT	WARRANT AMOUNT
10/20/2023	R. ARNOLD NET PAYROLL	2,709.29	\$ 2,709.29
10/20/2023	M. HUMPHREY NET PAYROLL	2,311.80	\$ 2,311.80
10/20/2023	B. VOGEL NET PAYROLL	2,475.03	\$ 2,475.03
10/20/2023	T. SHOGREN NET PAYROLL	2,752.62	\$ 2,752.62
10/20/2023	J. MARTY NET PAYROLL	1,801.66	\$ 1,801.66
10/20/2023	K. GELOS NET PAYROLL	2,772.81	\$ 2,772.81
10/20/2023	S. DUFFIELD NET PAYROLL	3,300.35	\$ 3,300.35
10/20/2023	M. WILCOX NET PAYROLL	2,392.11	\$ 2,392.11
10/20/2023	D. GROSHART NET PAYROLL	4,500.06	\$ 4,500.06
10/20/2023	EMPLOYMENT DEVELOPMENT DEPARTM ETT	2.19	
	SDI	316.67	
	SUI	32.78	
	STATE WITHHOLDING	1,108.05	\$ 1,459.69
10/20/2023	CALPERS RETIREMENT SYSTEM		
	PERS-IRC 457 CONTRIBUTIONS	2,433.50	
	PERS RETIREMENT	1,628.91	
	PERS RETIREMENT TIER 2	1,886.11	
	PERS RETIREMENT PEPRA	2,818.98	
	PERS SERVICE CREDIT PURCHASE	981.47	
	SURVIVOR BENEFIT	8.37	\$ 9,757.34

**HERITAGE RANCH COMMUNITY SERVICES DISTRICT
WARRANT REGISTER
OCTOBER 2023**

DATE	NAME OF PAYEE	ITEM AMOUNT	WARRANT AMOUNT
10/20/2023	INTERNAL REVENUE SERVICE FEDERAL WITHHOLDING TAXES MEDICARE	2,662.28 1,058.92	\$ 3,721.20
10/23/2023	J.B. DEWAR. INC. FUEL & OIL	918.46	\$ 918.46
10/23/2023	PG&E ELECTRICITY	4,272.83	\$ 4,272.83
10/24/2023	CALPERS RETIREMENT SYSTEM CALPERS UNFUNDED LIABILITY	8,760.67	\$ 8,760.67
10/27/2023	STATE WATER RESOURCES CONTROL LICENSES & PERMITS	110.00	\$ 110.00
10/27/2023	WATER SYSTEMS CONSULTING, INC. WRRF PROJECT	56,608.16	\$ 56,608.16
10/27/2023	GREAT WESTERN ALARM ALARM/ANSWERING SERVICE	350.32	\$ 350.32
10/27/2023	AT&T TELEPHONE	79.67	\$ 79.67
10/27/2023	USA BLUEBOOK MAINTENANCE FIXED EQUIPMENT CHEMICALS MAINTENANCE FIXED EQUIPMENT	175.89 177.98 2,352.55	\$ 2,706.42
10/27/2023	BRENNTAG PACIFIC, INC CHEMICALS	7,124.35	\$ 7,124.35
10/27/2023	STAR DRUG TESTING, INC PROFESSIONAL SERVICES	45.00	\$ 45.00
10/27/2023	ROY ARNOLD UNIFORM ALLOWANCE UNIFORM ALLOWANCE CELL PHONE/INTERNET ALLOWANCE	150.11 109.18 80.00	\$ 339.29
10/27/2023	CSDA DUES & SUBSCRIPTIONS	8,187.00	\$ 8,187.00

**HERITAGE RANCH COMMUNITY SERVICES DISTRICT
WARRANT REGISTER
OCTOBER 2023**

DATE	NAME OF PAYEE	ITEM AMOUNT	WARRANT AMOUNT
10/27/2023	RENTAL DEPOT EQUIPMENT RENT/LEASE	1,436.40	\$ 1,436.40
10/27/2023	ANTHONY'S TIRE STORE VEHICLES	297.40	\$ 297.40
10/27/2023	FLUID RESOURCE MANAGEMENT PROFESSIONAL SERVICES	710.00	\$ 710.00
10/27/2023	KRISTEN GELOS CELL PHONE/INTERNET ALLOWANCE	80.00	\$ 80.00
10/27/2023	CORE & MAIN LP METERS & EQUIP./SUPPLIES SUPPLIES SUPPLIES METERS & EQUIPMENT SUPPLIES SUPPLIES	991.45 178.39 1,717.64 109.46 697.13 501.97	\$ 4,196.04
10/27/2023	RHYTHM DESIGN UNIFORMS FY 23/24	102.50	\$ 102.50
10/27/2023	PITNEY BOWES GLOBAL FINANCIAL POSTAGE METER LEASE	161.79	\$ 161.79
10/27/2023	BURT INDUSTRIAL SUPPLY VEHICLES	40.86	\$ 40.86
10/27/2023	SCOTT DUFFIELD CELL PHONE/INTERNET ALLOWANCE	80.00	\$ 80.00
10/27/2023	WESTERN EXTERMINATOR STRUCTURES & GROUNDS	110.90	\$ 110.90
10/27/2023	MARK HUMPHREY UNIFORM ALLOWANCE CELL PHONE/INTERNET ALLOWANCE	271.86 80.00	\$ 351.86
10/27/2023	MID-STATE REPAIR SERVICE VEHICLES	802.34	\$ 802.34

**HERITAGE RANCH COMMUNITY SERVICES DISTRICT
WARRANT REGISTER
OCTOBER 2023**

DATE	NAME OF PAYEE	ITEM AMOUNT	WARRANT AMOUNT
10/27/2023	BRIAN VOGEL		
	UNIFORM ALLOWANCE	228.36	
	UNIFORM ALLOWANCE	109.18	
	CELL PHONE/INTERNET ALLOWANCE	80.00	\$ 417.54
10/27/2023	MIKE WILCOX		
	CELL PHONE/INTERNET ALLOWANCE	80.00	\$ 80.00
10/27/2023	TROY SHOGRN		
	CELL PHONE/INTERNET ALLOWANCE	80.00	\$ 80.00
10/27/2023	DOUGLAS GROSHART		
	CELL PHONE/INTERNET ALLOWANCE	80.00	\$ 80.00
10/27/2023	A.M. PECHE & ASSOCIATES LLC		
	PROFESSIONAL SERVICES	350.00	\$ 350.00
10/27/2023	JORANDA MARKETING, INC. / JAN- STRUCTURES & GROUNDS		
		274.60	\$ 274.60
10/27/2023	SPICE INTEGRATION		
	MAINT. FIXED EQUIP./GAC PROJECT	5,375.00	
	SCADA PROJECT	2,812.50	\$ 8,187.50
10/27/2023	HYDROPRO SOLUTIONS		
	METERS & EQUIPMENT	5,624.59	\$ 5,624.59
10/27/2023	AMERICAN WATER COLLEGE, LLC		
	TRAINING & TRAVEL	1,554.00	\$ 1,554.00
10/27/2023	HANK'S WELDING SERVICE, INC.		
	GAC PROJECT	300.00	\$ 300.00
10/27/2023	EVOQUA WATER TECHNOLOGIES LLC		
	GAC PROJECT	1,501.50	\$ 1,501.50
10/27/2023	MGE UNDERGROUND		
	MAINTENANCE FIXED EQUIPMENT	6,289.74	\$ 6,289.74
10/27/2023	JERED MARTY		
	UNIFORM ALLOWANCE	190.30	\$ 190.30

**HERITAGE RANCH COMMUNITY SERVICES DISTRICT
WARRANT REGISTER
OCTOBER 2023**

DATE	NAME OF PAYEE	ITEM AMOUNT	WARRANT AMOUNT
10/27/2023	CARBON HEALTH MEDICAL PROFESSIONAL SERVICES	190.00	\$ 190.00
TOTAL ALL WARRANTS			\$265,861.15

**HERITAGE RANCH COMMUNITY SERVICES DISTRICT
TREASURER'S REPORT
OCTOBER 2023**

SUMMARY REPORT OF ALL ACCOUNTS

Beginning Balance:	\$ 4,234,229
Ending Balance:	\$ 4,235,202
Variance:	\$ 974
Interest Earnings for the Month Reported:	\$ 37,981
Interest Earnings Fiscal Year-to-Date:	\$ 73,607

ANALYSIS OF REVENUES

Total operating income for water and sewer was:	\$ 205,332
Non-operating income was:	\$ 53,115
Franchise fees paid to the District by San Miguel Garbage was:	\$ 7,770
Interest earnings for the LAIF account was:	\$ 37,389
Interest earnings for the Five Star Bank checking account was:	\$ 10
Interest earnings for the Five Star Bank DWR Loan Services account was:	\$ 3
Interest earnings for the Five Star Bank DWR Reserve account was:	\$ 350
Interest earnings for the Mechanics Bank money market account was:	\$ (6,100)

ANALYSIS OF EXPENSES

Five Star Bank checking account total warrants, fees, and Electronic Fund Transfers was:	\$ (269,590)
--	--------------

STATEMENT OF COMPLIANCE

This report was prepared in accordance with the Heritage Ranch Community Services District Statement of Investment Policy. All investment activity was within policy limits. There are sufficient funds to meet the next 30 days obligations. Attached is a status report of all accounts and related bank statements.

HERITAGE RANCH COMMUNITY SERVICES DISTRICT
STATUS REPORT FOR ALL ACCOUNTS
OCTOBER 2023

BEGINNING BALANCE ALL ACCOUNTS		\$4,234,228.69
<hr/>		
OPERATING CASH IN DRAWER		\$ 300.00
<hr/>		
FIVE STAR BANK DWR LOAN REPAYMENT (1994-2029):		
BEGINNING BALANCE 9/30/2023	916.36	
QUARTERLY DEPOSIT	-	
INTEREST EARNED	2.74	
SEMI-ANNUAL PAYMENT	-	
ENDING BALANCE 10/31/2023		\$ 919.10
<hr/>		
FIVE STAR BANK DWR RESERVE ACCOUNT		
BEGINNING BALANCE 9/30/2023	116,866.65	
INTEREST EARNED	349.67	
ENDING BALANCE 10/31/2023		\$ 117,216.32
<hr/>		
FIVE STAR BANK SDWSRF LOAN SERVICES ACCOUNT		
BEGINNING BALANCE 9/30/2023	15,352.79	
QUARTERLY DEPOSIT	-	
INTEREST EARNED	45.94	
SEMI-ANNUAL PAYMENT	-	
ENDING BALANCE 10/31/2023		\$ 15,398.73
<hr/>		
FIVE STAR BANK SDWSRF RESERVE ACCOUNT		
BEGINNING BALANCE 9/30/2023	60,477.17	
INTEREST EARNED	180.95	
ENDING BALANCE 10/31/2023		\$ 60,658.12
<hr/>		
MECHANICS BANK MONEY MARKET ACCOUNT		
BEGINNING BALANCE 9/30/2023	9,399.38	
DEPOSIT REVENUE - CASH	2,178.26	
INTEREST EARNED	0.08	
REVENUE TRANSFER <i>To Five Star Checking</i>	(6,100.00)	
ENDING BALANCE 10/31/2023		\$ 5,477.72
<hr/>		
FIVE STAR BANK - MONEY MARKET		
BEGINNING BALANCE 9/30/2023	877.36	
INTEREST EARNED	2.63	
ENDING BALANCE 10/31/2023		\$ 879.99
<hr/>		

**HERITAGE RANCH COMMUNITY SERVICES DISTRICT
STATUS REPORT FOR ALL ACCOUNTS
OCTOBER 2023**

FIVE STAR BANK - CHECKING		
BEGINNING BALANCE 9/30/2023	18,381.91	
DEPOSIT REVENUE & MISCELLANEOUS INCOME	236,504.26	
INTEREST EARNED	9.63	
TOTAL CHECKS, FEES AND EFT'S	(269,590.05)	
REVENUE TRANSFER <i>From LAIF</i>	100,000.00	
ENDING BALANCE 10/31/2023		\$ 85,305.75

LOCAL AGENCY INVESTMENT FUND (LAIF)		
BEGINNING BALANCE 9/30/2023	4,011,657.07	
INTEREST EARNED	37,389.41	
REVENUE TRANSFER <i>To Five Star Checking</i>	(100,000.00)	
ENDING BALANCE 10/31/2023		\$3,949,046.48

ENDING BALANCE ALL ACCOUNTS		\$4,235,202.21
DIFFERENCE FROM LAST MONTH	Increase	\$ 973.52

**HERITAGE RANCH COMMUNITY SERVICES DISTRICT - CONSOLIDATED BUDGET
2023/24 Budget**

OPERATING REVENUE	Budget FY 23/24	Actual October	Actual Year to Date	Percentage Year to Date	Variance Explanation
Water Fees	1,364,806	126,572	536,658	39%	
Sewer Fees	1,018,537	76,080	304,020	30%	
Hook-Up Fees	2,400	0	0	0%	
Turn on Fees	3,500	175	1,100	31%	
Late Fees	18,830	2,505	10,658	57%	
Plan Check & Inspection	1,600	0	0	0%	
Miscellaneous Income	500	0	917	183%	
TOTAL OPERATING	\$2,410,173	\$205,332	\$853,352	35%	

FRANCHISE REVENUE					
Solid Waste Franchise Fees	88,698	7,770	33,727	38%	
TOTAL FRANCHISE	\$88,698	\$7,770	\$33,727	38%	

TOTAL OPERATING \$2,498,871 \$213,101 \$887,079 35%

NON-OPERATING REVENUE					
Standby Charges	242,200	0	7,329	3%	
Property Tax	454,384	15,134	25,028	6%	
Interest	30,000	37,981	73,607	245%	
Connection Fees	70,580	0	0	0%	
TOTAL NON-OPERATING	\$797,164	\$53,115	\$105,963	13%	

RESERVE REVENUE					
Capital Reserves	539,887	22,978	69,230	13%	
Operating Reserves	1,767,061	51,676	157,369	9%	
TOTAL RESERVE	\$2,306,948	\$74,654	\$226,600	10%	

TOTAL NON-OPERATING \$3,104,112 \$127,769 \$332,563 11%

TOTAL ALL INCOME	\$5,602,983	\$340,870	\$1,219,643	22%	
-------------------------	--------------------	------------------	--------------------	------------	--

**HERITAGE RANCH COMMUNITY SERVICES DISTRICT - CONSOLIDATED BUDGET
2023/24 Budget**

OPERATING EXPENSES

SALARIES AND BENEFITS	Budget FY 23/24	Actual October	Actual Year to Date	Percentage Year to Date	Variance Explanation
Salaries	993,973	69,836	269,953	27%	
Health Insurance	183,739	13,202	51,006	28%	
Health Insurance - Retirees	51,408	3,994	15,975	31%	
Pers Retirement	176,138	15,856	62,752	36%	
OPEB Funding/Transfer	10,181	0	0	0%	
Standby	13,200	655	3,404	26%	
Overtime	7,930	168	1,964	25%	
Workers Comp. Ins.	24,000	0	23,025	96%	
Directors' Fees	36,000	500	1,800	5%	
Medicare/FICA	14,616	1,066	4,144	28%	
Car Allowance	3,000	250	1,000	33%	
SUI/ETT	1,000	0	0	0%	
Uniforms	5,000	1,723	2,765	55%	
TOTAL SALARIES & BENEFITS	\$1,520,185	\$107,249	\$437,789	29%	

UTILITIES

Electricity	129,263	10,456	44,259	34%	
Propane	1,525	0	0	0%	
Water Purchase	28,600	0	15,848	55%	
Telephone/Internet	12,801	1,358	4,796	37%	
TOTAL UTILITIES	\$172,189	\$11,814	\$64,903	38%	

MAINTENANCE & SUPPLIES

Chemicals	82,160	11,749	39,328	48%	
Computer/Software	35,256	130	6,638	19%	
Equip. Rental/Lease	2,600	2,873	7,182	276%	
Fixed Equip.	194,480	17,113	76,888	40%	
Fuel & Oil	15,600	918	5,534	35%	
Lab Testing	61,360	3,962	12,907	21%	
Office Supplies	1,560	63	145	9%	
Parks & Recreation	1,000	0	0	0%	
Struct./Grnds.	15,537	771	5,996	39%	
Small Tools/Equip.	3,120	1,520	3,531	113%	
Supplies	4,680	4,799	6,130	131%	
Meters/Equip.	12,480	6,165	6,485	52%	
Vehicles	6,240	1,789	3,056	49%	
TOTAL MAINT. & SUP.	\$436,073	\$51,852	\$173,820	40%	

**HERITAGE RANCH COMMUNITY SERVICES DISTRICT - CONSOLIDATED BUDGET
2023/24 Budget**

GENERAL & ADMINISTRATION	Budget FY 23/24	Actual October	Actual Year to Date	Percentage Year to Date	Variance Explanation
Ads./Advertising	1,500	0	958	64%	
Alarm/Answering Service	4,160	664	1,524	37%	
Audit	10,000	0	0	0%	
Bank Charges/Fees	1,000	0	0	0%	
Consulting/Engineering	10,000	0	3,298	33%	
Dues/Subscription	10,400	8,187	5,212	50%	
Elections	0	0	0	0%	
Insurance	44,000	0	44,797	102%	Paid Annually
LAFCO	7,700	0	7,281	95%	Paid Annually
Legal/Attorney	25,000	2,350	7,910	32%	
Licenses/Permits	30,160	110	70	0%	
Plan Check & Inspection	1,600	0	1,533	96%	
Postage/Billing	15,600	1,575	4,735	30%	
Professional Service	92,872	4,076	12,505	13%	
Tax Collection	7,300	0	0	0%	
Staff Training & Travel	12,480	2,252	4,176	33%	
Board Training & Travel	1,000	625	625	63%	
TOTAL G & A	\$274,772	\$19,838	\$94,623	34%	

CAPITAL PROJECTS & EQUIPMENT

Structures/Improvements	2,271,948	74,654	226,600	10%	
Equipment	35,000	0	0	0%	
TOTAL CAPITAL EXPENSE	\$2,306,948	74,654	226,600	10%	

DEBT

State Loan Payment	103,629	0	51,814	50%	
State Loan Payment Phase II	58,740	0	0	0%	
Western Alliance Lease-PVS	153,314	0	76,580	50%	
TOTAL DEBT	\$315,683	\$0	\$128,395		

FUNDED DEPRECIATION	\$288,000	\$24,000	\$96,000	33%	
UNFUNDED DEPRECIATION	\$0	\$0	\$0	0%	

TOTAL EXPENSE	\$5,313,850	\$289,407	\$1,222,129	23%	
----------------------	--------------------	------------------	--------------------	------------	--

CAPACITY CHARGES TRANSFER \$70,580 \$0 \$0 0%

SOLID WASTE FEES TRANSFER \$26,109 \$2,405 \$9,942 38%

FUND TOTAL	\$192,444	\$49,058	(\$12,428)		
-------------------	------------------	-----------------	-------------------	--	--

**HERITAGE RANCH COMMUNITY SERVICES DISTRICT
OFFICE REPORT**

OCTOBER 2023

Utility Billing

- On November 1st, 1,939 bills were processed for a total dollar amount of \$197,655 for water and sewer user fees for the month of October.
- We processed 267 penalties for bills that were due by October 25th.
- We mailed out 38 Intent To Disconnect letters to customers that were more than 60 days delinquent.
- We issued 15 48-hour notices and locked off 9 meters for non-payment.

Customer Service Orders

- Staff completed a total of 48 service orders for the month of October. The breakdown by job code is as follows:

LOCK METER	9	OCCUPANT CHANGE	11
METER SWAP	21	UNLOCK	5
PRESSURE CHECK	1	LEAK	1

Administration

- Nothing to report.

San Miguel Garbage Franchise Fees Received

- The total Franchise Fees received for the Month of September was \$ 7,769.55. The breakdown is as follows:

Residential Garbage Collection - \$ 6,020.80
Commercial Garbage Collection - \$ 1,028.00
Roll-Off Collection - \$ 720.75

HERITAGE RANCH COMMUNITY SERVICES DISTRICT

District Engineer Report For the Month of November 2023

In addition to normal engineering and administrative duties, below are updates for several areas of work:

Operations Support

- Working with Operations Staff re:
 - GAC project operation, troubleshooting for pilot study
 - Lift station refurbishment project (needs, preferences, etc.)
 - PRV project for order and scope of work

Capital Improvement Projects

Projects / equipment replacement planned for this fiscal year and their status include:

- DBP/Compliance: See separate agenda item and report regarding this issue.
- SCADA water system: As of 9/14/23, the new SCADA system is completely installed and running.
- SCADA Telemetry survey: Working with SPICE and HROA to complete telemetry connections throughout the service area.
- SCADA wastewater collection system: As we begin the lift station refurbishment project, wastewater SCADA will be an important portion of the project. Working with operations and SPICE to determine the best path forward and what to include in SCADA project vs. refurbishment project.
- PRV Project – Contractor selection will be complete the week of 11/13/23. Verbal update to be provided at the meeting re: contractor, schedule and budget.
- Lift Station 1-5 rehabilitation design phase: Project scoping is underway with LS #3 as the top priority, followed by #2 and then #1. All SCADA will be updated at all 5 lift stations as well.
- Wastewater collection system model and infiltration / inflow: Working with vendors to determine the best way to move forward. We have discussed GIS, smoke testing and video inspection with vendors. The next step is determining the scope/phasing of the assessment and obtaining pricing from vendors for the work.

- WRRF Project – Continuing to work with the General Manager and WSC to move the design forward.

HERITAGE RANCH COMMUNITY SERVICES DISTRICT

Operations Report For the Month of October 2023

Water treatment

- The Operations staff has made no operational changes to the water treatment process since last month's report. Replacement Carbon tanks for the GAC system were installed, backwashed according to manufacturer's specifications, and put into service this past Monday. Additional improvements in the planning phases include but are not limited to chemical injection refinement and safety entailing continuing upgrades to all chemical injection stations and fully integrating them into the PLC programming. This will enhance the Operator's ability to adjust chemical feed rates and obtain immediate feedback from those adjustments.
- Staff are working clean sediment from the spent backwash basins at the plant. This is an arduous task that entails isolating basins, dewatering the beds, and removing sludge for drying and offsite transport.

Water distribution

- Meter register replacements continue with the installation of 26 additional meter registers.
- Staff will begin the task of service line inventory as mandated by the CA Water Boards. This is a component of the revised Lead and Copper rule.

Wastewater collection

- The collection of data from lift stations and lack of alarms due to SCADA failure continues to be an urgent problem. SPICE is working with staff to develop a solution to the telemetry project that will best set us up for the next phase of fully integrating all satellite facilities for communication. The telemetry or communications project will not immediately eliminate the problem, but it will give us a solid platform to build on for the upcoming lift station SCADA project.

Wastewater treatment

- One of the aerators was recently taken out of service, cleaned, and re-tethered with new cable clamps and electrical cable. Another aerator is scheduled for electric rewind service.

Facilities

- Staff will be working on backfilling a long-time erosion problem at the water treatment plant between the spent backwash basins and one of the solar arrays.

Vehicles and equipment

- Deferred maintenance continues on the fleet with general drivability and safety being the focus.

HERITAGE RANCH COMMUNITY SERVICES DISTRICT

MEMORANDUM

TO: Board of Directors

FROM: Scott Duffield, General Manager

DATE: November 16, 2023

SUBJECT: Discussion regarding the Water Resource Recovery Facility project: 1) Receive the Initial Study - Mitigated Negative Declaration; 2) Receive the 60% Design; and 3) Receive finance plan update.

Recommendation

It is recommended that the Board of Directors receive and discuss items associated with the Water Resource Recovery Facility Upgrade project.

Background

Since March 2021, your Board has been pursuing the Water Resource Recovery Facility Project (Project) and has formally made numerous decisions:

- 3/18/21 Authorized moving forward with the Project
- 5/20/21 Authorized RFQ/P for Design Phase professional services
- 8/12/21 Selected WSC as Design Phase professional services
- 11/18/21 Adopted a Project Charter
- 5/19/22 Determined flows and loads methodology
- 6/15/23 Determined flows and loads methodology – updated analysis
- 7/20/23 Discussed site layout considerations and the MBR equipment procurement process
- 8/22/23 Received the 30% Design
- 9/21/23 Approved the bid documents and authorized advertising for MBR equipment procurement
- 10/19/23 Authorized a rate study

Discussion

Environmental Document

The environmental document was written by WSC's sub-consultant Rincon. The Project impacts are limited such that the environmental document is an Initial Study – Mitigated Negative Declaration (IS-MND), as opposed to a full-blown Environmental Impact Report (EIR). The IS-MND complies with the California Environmental Quality Act (CEQA), and since we are seeking funding from the United States Department of Agriculture (USDA), it also complies with National Environmental Policy Act (NEPA) requirements. The IS-MND is straight forward and impacts to the project and environment are minimal.

Proposed mitigation measures include standard provisions such as waste recycling, dust and erosion control and monitoring for paleontological resources during excavation.

As part of the IS-MND, the District complied with AB 52 which requires public agencies to consult with tribes during the CEQA process. The goal of AB 52 is to promote the involvement of California Native American Tribes in the decision-making process when it comes to identifying and developing mitigation for impacts to resources of importance to their culture.

The draft IS-MND is available on our website to receive, file, and provide any additional comments during the public noticing period, which is November 17, 2023 through December 18, 2023. It is anticipated that the final IS-MND will be presented to your Board for adoption during the first quarter of 2024 likely at the January meeting.

60% Design

At the August 22, 2023 meeting, your Board received the 30% Design. Since that time, WSC and staff have furthered the design, and we are incorporating several cost-saving measures. During the design process it also became apparent that a section of the effluent pipeline needs to be upgraded to accommodate design parameters. A few examples of cost-saving measures by design are:

- The operations building has been deleted from the project and operator workspaces will be accommodated either in the existing office building or in a remodeled shop bay.
- There will be only one coarse screen with a manual bypass rather than two coarse screens at the Headworks, with an integrated washer and compactor resulting in a simplified design.
- The effluent pumps will serve multiple purposes including conveyance of off-spec. water to the Equalization Basin precluding the need for stand-alone pumps for that purpose.
- The shape of the Chemical area has been simplified and the size reduced to save in construction costs.

The draft 60% Design is available on our website to receive, file, and provide any additional comments within the next week. The 60% Design and associated engineer's estimate will

inform the rate study being performed by Tuckfield & Associates. It is anticipated that the rate study will be presented to your Board during the first quarter of 2024.

Finance plan update

The District needs to fund the Project and does not currently have adequate means by which to purchase the Project equipment, including the packaged MBR, nor construct the Project as a whole. The FY 2023/24 Budget includes budget from cash reserves for design phase services only. At the October 19, 2023 meeting, your Board initiated a sewer rate study. A successful Proposition 218 process will need to follow that will provide funding for the Project.

In addition, funding and financing providers, including Federal and/or State agencies such as USDA and/or Department of Water Resources, require a financial analysis and will need assurance that the Project can be paid for prior to any funding approval, i.e., rates are, or are going to be in place at the time of funding approval.

Staff and the finance team will be working closely with the design team and the rate consultant.

Results

The public noticing process for the IS-MND allows the public an opportunity to comment on the project, the proposed impacts and mitigation measures in accordance with the CEQA / NEPA process. Your Board will adopt the IS-MND at a subsequent meeting once the public review process is completed. The Board members can review and comment on the IS-MND during the public review period.

Directors should direct any comments on the 60% Design to staff within one week of this meeting.

Support of staff and consultants, the rate study, and finance team, will help to provide the community with cost-effective, adaptable wastewater treatment that achieves reliable compliance and sustainably meets the long-term needs of the community and environment.

Attachments: Draft Initial Study - Mitigated Negative Declaration (website and Clerk's file)
60% Design (website and Clerks file)

File: Projects_WRRF

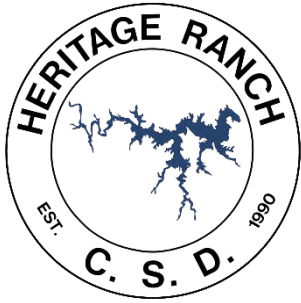

60% Design Report

Water Resource Recovery Facility Upgrades

OCTOBER 31, 2023

HERITAGE RANCH COMMUNITY SERVICES DISTRICT





HERITAGE RANCH COMMUNITY SERVICES DISTRICT

60% Design Report

OCTOBER 2023



Prepared by Water Systems Consulting, Inc



ACKNOWLEDGEMENTS

The Preliminary Design Report was prepared by Water Systems Consulting, Inc. The primary authors are listed below.



Matthew Rodrigues, PE

Lizzie Wiley, EIT

Dylan Wade, PE

Water Systems Consulting, Inc. would like to acknowledge the significant contributions of Heritage Ranch Community Services District. The primary contributors are listed below.

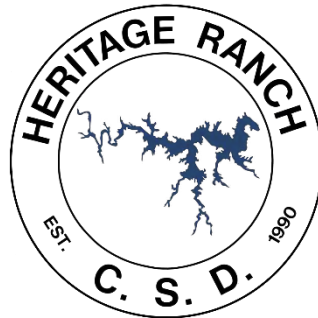

Scott Duffield, PE

Doug Groshart, PE

Mike Wilcox

TABLE OF CONTENTS

Executive Summary	1
Background	2
Project Overview	3
Flows and Loads	7
Implementation and Next Steps.....	10
1.0 Introduction	1-1
1.1 Background.....	1-2
1.2 Existing Facilities	1-2
1.3 Prior Preliminary Design Work	1-7
1.4 Scope of Upgrades	1-8
1.5 Program Charter	1-9
2.0 Site Planning Evaluation.....	2-1
2.1 Approach	2-2
2.2 Evaluation	2-4
2.3 Effluent Disposal Site.....	2-8
2.4 Conclusions	2-8
3.0 Design Confirmation	3-1
3.1 Approach	3-2
3.2 Alternatives Evaluation	3-3
3.3 Outcome	3-10
4.0 Design Criteria.....	4-1
4.1 Effluent Requirements	4-2
4.2 Wastewater Characterization	4-4
4.3 Design Flows and Loads.....	4-13
4.4 Design Standards	4-14
5.0 Planned WRRF Upgrades	5-1
5.1 Overview.....	5-2
5.2 Facility Hydraulics	5-5
5.3 Process Units.....	5-11
5.4 Existing Facilities	5-24
5.5 Electrical, Instrumentation, and Control Facilities	5-25
5.6 Building Programming.....	5-30

- 5.7 Geotechnical Conditions 5-32
- 6.0 Staffing Requirements 6-1
 - 6.1 Approach 6-2
 - 6.2 Staffing Requirements 6-2
 - 6.3 Recommendations 6-4
- 7.0 Implementation 7-1
 - 7.1 Continuation of Existing Operations 7-2
 - 7.2 Design and Construction Schedule 7-2
 - 7.3 Project Cost Opinion 7-5
 - 7.4 Next Steps 7-6
- Appendix A Time Schedule Order R3-2022-0046 A
- Appendix B Program Charter B
- Appendix C Site Survey C
- Appendix D Wastewater Characterization TM D
- Appendix E Soils Engineering Report E

LIST OF FIGURES

Figure 1 HRCSD WRRF Upgrade Process Flow Diagram	5
Figure 2 Site Plan	6
Figure 3 WRRF Upgrades Design and Construction Schedule	11
Figure 4 Pond 1 and Influent Force Mains.....	1-3
Figure 5 Existing Effluent Pump Station	1-5
Figure 6 Existing Disinfection Facility	1-5
Figure 7 Pond 3 Effluent Storage Pond.....	1-5
Figure 8 Existing Sand Filters	1-6
Figure 9 Existing Outfall	1-6
Figure 10 Existing Dechlorination Point.....	1-6
Figure 11 WWTP Area Designations and Process Areas.....	2-3
Figure 12 WWTP Site Planning Decisions and Availability	2-6
Figure 13 Available Space for WRRF Upgrades	2-7
Figure 14 Site Plan	2-10
Figure 15 Packaged MBR Alternative Site Layout.....	3-5
Figure 16 Site Built MBR Alternative Site Layout.....	3-6
Figure 17 HRCSD WRRF Upgrade Process Flow Diagram.....	5-4
Figure 18 Preliminary Hydraulic Profile	5-6
Figure 19 Dry Weather Diurnal Flow Patterns	5-8
Figure 20 Diurnal Inflow Cumulative Diagram	5-8
Figure 21 Wet Weather Flow Equalization for Different Design Flow Scenarios	5-10
Figure 22 Existing Effluent Chlorination Dosing Point	5-21
Figure 23 Existing WWTP Single Line Diagram	5-28
Figure 24 Proposed Single Line Diagram for Upgraded WRRF.....	5-29
Figure 25 Geotechnical Site Investigation Trenching Locations	5-33
Figure 26 WRRF Upgrades Design and Construction Schedule	7-3

LIST OF TABLES

Table 1 WDR Order No. R3-2017-0026 Discharge Requirements.....	3
Table 2 Historical Flows and Loads from 2017- March 2023	8
Table 3 Design Flows and Loads	9
Table 4 Physical and Design Characteristics of Aerated Ponds	1-4
Table 5 Alternatives from 2021 Preliminary Engineering Memorandum (2)	1-7
Table 6 Site Planning Notes and Decisions.....	2-5
Table 7 Project Elements of MBR Alternatives	3-3
Table 8 Representative Manufacturers and Equipment for MBR Alternatives	3-4
Table 9 Main Cost Differences of MBR Alternatives	3-7
Table 10 Capital Cost Breakdown	3-8
Table 11 MBR Alternative Total Capital Cost Comparison	3-9
Table 12 Non-Economic Criteria for MBR Alternatives Analysis	3-10
Table 13 WDR Order No. R3-2017-0026 Discharge Requirements.....	4-3
Table 14 Purpose of Averaging Periods for Design Application.....	4-5
Table 15 Historical Flows and Loads from 2017-March 2023	4-9
Table 16 Historical Flow Peaking Factors	4-10
Table 17 Historical Loadings and Peaking Factors.....	4-11
Table 18 Projected Flows and Loads	4-12
Table 19 Design Flows and Loads	4-13
Table 20 Coarse Screen Design Criteria	5-11
Table 21 Equalization Basin Design Criteria	5-12
Table 22 Equalization Basin Pump Station Design Criteria	5-13
Table 23 Packaged MBR Design Criteria	5-15
Table 24 Dewatering Facility Design Criteria.....	5-17
Table 25 Utility Water System Demands	5-19
Table 26 Effluent and UW Pump Station Design Criteria.....	5-20

Table 27 Chemical List and Facility Design Criteria	5-23
Table 28 Changes to Existing Facilities for WRRF Upgrades.....	5-24
Table 29 New and Existing Buildings for WRRF Upgrades	5-31
Table 30 Staffing Requirements by Process or Activity	6-3
Table 31 Upgraded WRRF Staffing Requirements Summary.....	6-4
Table 32 HRCSD WWTP Personnel FY22.....	6-4
Table 33 Class 2 Project Cost Opinion.....	7-6

ACROYNMS & ABBREVIATIONS

AA	average annual
AACE	AACE International
ADWF	average dry weather flow
ATS	automatic transfer switch
BGS	below ground surface
BOD	biochemical oxygen demand
CBC	California Building Code
CCRWQCB	Central Coast Regional Water Quality Control Board
CFC	California Fire Code
CM	construction management
COD	chemical oxygen demand
CPO	Chief Plant Operator
CSD	Community Services District
DISTRICT	Heritage Ranch Community Services District
DOIC	Designated Operator-In-Charge
EI&C	electrical, instrumentation and control
ESDC	engineering services during construction
F/M	food-to-microorganism ratio
FTE	full time equivalent
HP	horsepower
IES	Illuminating Engineering Society
IS	Initial Study
IS-MND	Initial Study-Mitigated Negative Declaration
KVA	kilovolt ampere
KWHR	kilowatt-hour
MBR	membrane bioreactor
MCC	motor control center
MD	maximum day
MG	million gallons
mg/L	milligrams per liter
MGD	million gallons per day
mL/L	milliliters per liter
MLE	Modified Ludzack Ettinger
MLSS	mixed liquor suspended solids

Acronyms & Abbreviations

MM	maximum month
MND	Mitigated Negative Declaration
MPN	most probable number
MW	maximum week
NFPA	National Fire Protection Agency
OIT	Operator-in-Training
OIT	operator interface terminal
PDR	Preliminary Design Report
PEM	Preliminary Engineering Memorandum
PER	Preliminary Engineering Report
PFD	process flow diagram
PG&E	Pacific Gas and Electric Company
PH	peak hour
PPD	pounds per day
PPE	personal protective equipment
PVC	polyvinyl chloride
RAS	return activated sludge
SCADA	Supervisory Control and Data Acquisition
SLO COUNTY	San Luis Obispo County
SLO APCD	San Luis Obispo County Air Pollution Control District
SRT	solids retention time
SWRCB	State Water Resources Control Board
TBD	to be determined
TM	Technical Memorandum
TSO	Time Schedule Order
TKN	total Kjeldahl nitrogen
TSS	total suspended solids
USDA	United States Department of Agriculture
UV	ultraviolet
UW	utility water
VAC	volts alternating current
VSS	volatile suspended solids
WAS	waste activated sludge
WDR	Waste Discharge Requirement
WRRF	Water Resource Recovery Facility
WWTP	Wastewater Treatment Plant
µg/L	micrograms per liter

Executive Summary

This section provides a summary of the findings within this Preliminary Design Report. Detailed information is included in subsequent chapters and appendices of this report.

IN THIS SECTION

- Background
- Project Overview
- Flows and Loads
- Implementation and Next Steps

Background

Heritage Ranch Community Services District (District) provides municipal services to most of the Village of Heritage Ranch in north San Luis Obispo County, including wastewater collection and treatment. The District owns and operates the collection system pipelines and lift stations, and a centralized wastewater treatment plant (WWTP). The existing WWTP is an aerated pond system that produces disinfected secondary treated effluent that is discharged to an ephemeral drainage way which is tributary to the Nacimiento River.

In 2017, the District renewed their Waste Discharge Requirements (WDR) for their WWTP with the Central Coast Regional Water Quality Control Board (CCRWQCB). The updated WDR (Order No. R3-2017-0026) included more stringent limits for total recoverable copper and un-ionized ammonia, as well as a 10 mg/L-N nitrate limit.

Recognizing that the District had not been meeting existing WDR effluent requirements and could not immediately meet the new effluent requirements through operational optimization or minor changes to their existing treatment system, the District requested and received Time Schedule Order (TSO) No. R3-2018-0011 in 2018. The TSO, which was extended in October 2022 (TSO R3-2022-0046), requires full compliance with effluent requirements from WDR R3-2017-0026 by September 30, 2027.

Prior work determined significant upgrades to the District's WWTP are required to meet the WDR permit limits and the TSO. The resultant project is an upgrade of the District's WWTP to a water resource recovery facility (WRRF) capable of nitrification and denitrification (WRRF Upgrades), which is described in this 60% Design Report (Report). The WRRF Upgrades will be funded by the District's sewer fund and a combination of grants and/or low interest loans from the United States Department of Agriculture (USDA) Rural Development Water & Waste Disposal Loan & Grant Program. The total cost opinion for the WRRF Upgrades, including construction costs, construction contingency, and implementation costs for engineering services during construction and construction management is \$24,526,000 in November 2023 dollars.

The WRRF Upgrades Program represents one of the most significant investments in the District's history. To establish a clear and consistent vision and mission, and a set of goals and objectives, the District project staff, the District Board, and WSC developed a Program Charter through collaboration in a workshop setting. The Vision and Mission of the WRRF Upgrade Program, are:

Vision: Provide cost-effective, adaptable wastewater treatment that achieves reliable compliance and sustainably meets the long-term needs of the community and environment.

Mission: Deliver a new Water Resource Recovery Facility that exceeds regulatory requirements and positions the District to maximize the beneficial use of recycled water.

The Program Charter sets the tone for all work to be performed on the Program and serves as a valuable reference for those contributing to the Program's success.

Project Overview

New effluent limitations for copper, unionized ammonia, and nitrate were established in WDR Order No. R3-2017-0026 and carried through to TSO No. R3-2022-0046, as summarized in Table 1 by constituent and compliance period. The existing WWTP cannot be easily modified or operationally optimized to meet the new permit limits, specifically un-ionized ammonia, nitrate, and copper. The most notable discharge permit requirements that drive the intensity of treatment requirements are the daily maximum nitrate limit of 10 mg/L as N, and the 30-day average un-ionized ammonia limit of 0.025 mg/L. These limits require a nitrification-denitrification process capable of consistently meeting the nitrogen limits.

Table 1 WDR Order No. R3-2017-0026 Discharge Requirements

Constituent	30-Day Average	7-Day Average	Daily Maximum
Biochemical Oxygen Demand (BOD) (mg/L)	30	45	90
Total Suspended Solids (TSS) (mg/L) ¹	30	45	90
BOD and TSS Removal	85%	-	-
pH ¹	6.0 - 8.3		
Nitrate (as N) (mg/L)	-	-	10
Oil and Grease (mg/L)	10	-	20
Chlorine, Total Residual (µg/L)	-	-	ND ²
Settleable Solids (mL/L)	-	-	0.1
Unionized Ammonia (mg/L)	0.025	-	-
Copper, Total Recoverable (µg/L)	11	-	22
Fecal Coliform Bacteria (MPN/100 mL)	200/400	-	-
Total Coliform Bacteria (MPN/100 mL)		23 ³	2,400
<p>^[1] Applied as an instantaneous effluent limitation.</p> <p>^[2] Non-detected by amperometric titration or an equally sensitive method.</p> <p>^[3] This is a seven sample median.</p>			

Aside from repurposing the existing treatment ponds for storage space and flow equalization, the existing treatment and conveyance facilities at the existing WWTP site will be demolished to create available space for new facilities. Minor modifications will be made to the effluent disposal site for conveyance and dechlorination improvements. The WRRF Upgrades include construction of the following facilities:

- **Influent Splitter Box** to intercept and combine raw influent flows from the three (3) terminal lift stations in the collection system and convey wastewater to either the Equalization Basin or the Headworks facility.
- **Equalization Basin** to attenuate peak flows to the treatment process and provide diurnal flow and load equalization to provide more stable treatment.
- **Headworks** facility consisting of coarse screening.
- **Packaged MBR** activated sludge system to provide full nitrification-denitrification and direct filtration as well as pre-membrane fine screening.
- **Effluent and Utility Water Pump Station** to provide effluent pumping to the discharge location, utility water supply to in-plant uses, and provisions for future recycled uses.
- **Chemical Facility** for storage of chemicals required for MBR cleaning and effluent disinfection.
- **Dewatering Facility** to provide dewatering of WAS from the MBR system and short-term storage of dewatered solids within a building.
- **Electrical Building** to house motor control centers (MCC) and power distribution system.
- **Standby Generator** to provide backup power to operate the WRRF.

Existing Maintenance Building Retrofits to provide space for operator workstations, supervisory control and data acquisition (SCADA) interfaces, and bathroom facilities for onsite operations and maintenance staff. A process flow diagram of the treatment process is shown in Figure 1 and a conceptual site layout of the proposed WRRF Upgrades is shown in Figure 2.

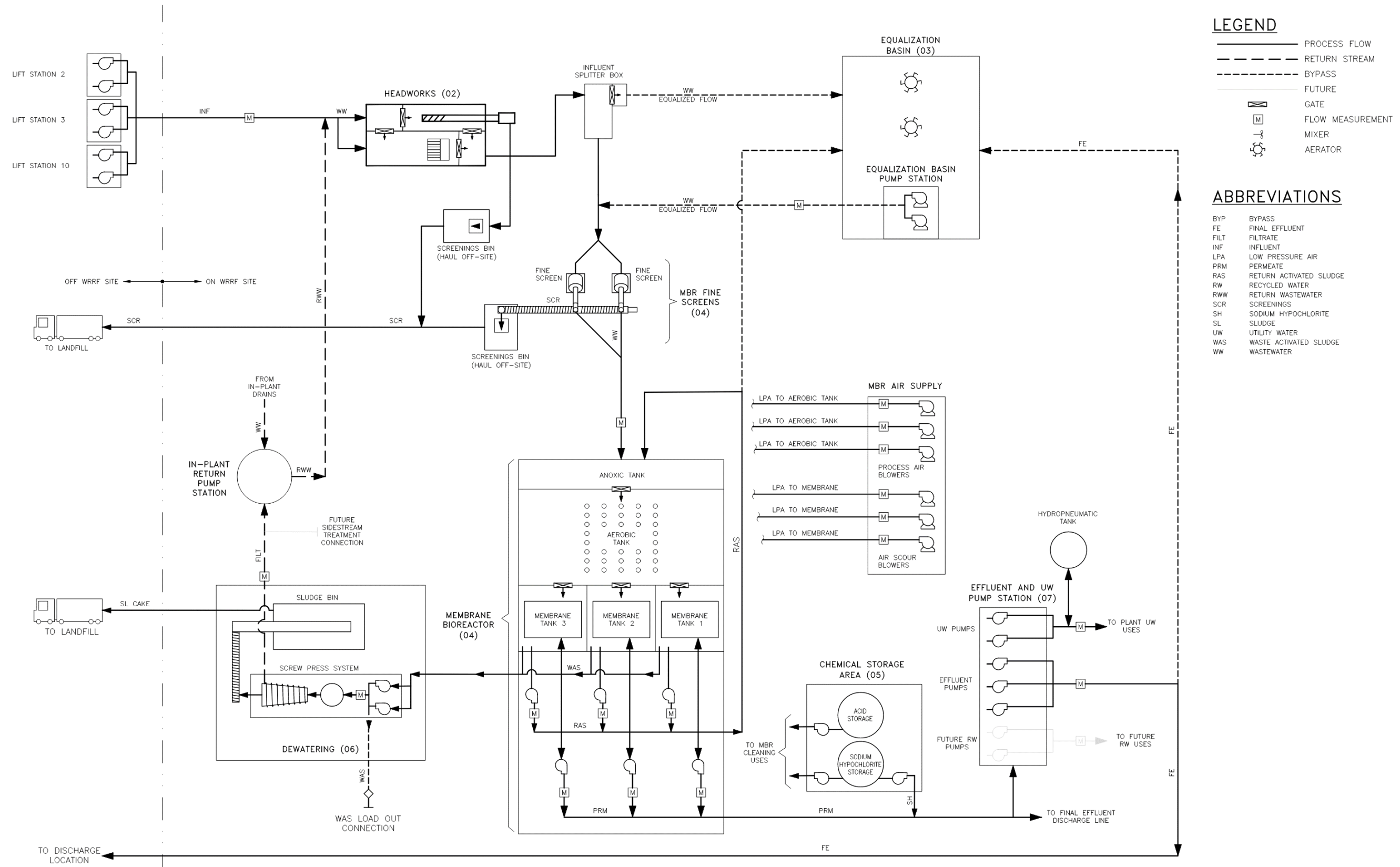

Figure 1 HRCSD WRRF Upgrade Process Flow Diagram

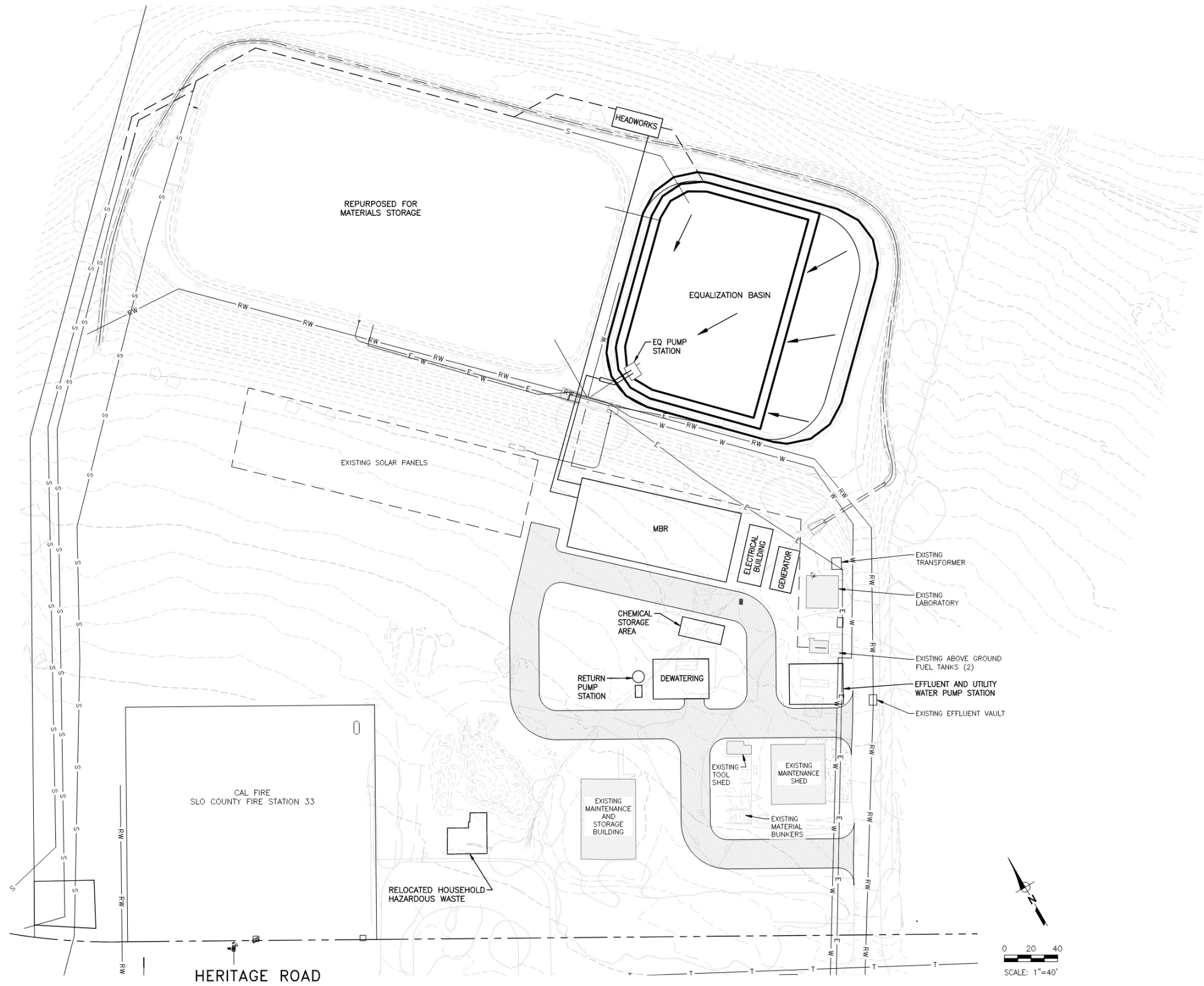

Figure 2 Site Plan

Flows and Loads

A wastewater characterization of the raw influent at the District's WWTP was performed to quantify historical flows and pollutant loads. Quantifying historical flows and loads over different averaging periods provides a basis for projecting future flows and loads using metrics for anticipated service area growth. Selection of averaging periods is necessary for development of design criteria for treatment process sizing, as well as alignment with relevant effluent discharge permit conditions (e.g., average monthly, average weekly, maximum daily, etc.). Selecting the appropriate averaging periods for influent wastewater characterizations supports treatment process sizing and compliance with permit conditions. The following averaging periods for flows and loads analysis were analyzed as part of the preliminary design wastewater characterization:

- Flow Averaging Periods
 - Average Annual (AA)
 - Average Dry Weather Flow (ADWF)
 - Average Wet Weather Flow (AWWF)
 - Maximum Month (MM)
 - Maximum Week (MW)
 - Maximum Day (MD)
 - Peak Hour (PH)
- Loading Averaging Periods
 - Average Annual (AA)
 - Maximum Month (MM)
 - Maximum Week (MW)
 - Maximum Day (MD)

The District provided flow and influent pollutant concentration data for the prior 10-years for the wastewater characterization analysis. Upon review, it was determined that the District did not have any raw influent flow metering data for the existing WWTP and the WWTP effluent flow data could not be accurately adjusted to represent influent flows. A combination of terminal lift station flow data from the District's collection system, flow meter testing at those lift stations, and Pacific, Gas & Electric (PG&E) power consumption data was used to estimate daily influent flows. Based on the flow analysis of the prior 10-years, a 6-year timeframe from 2017 through 2022 was selected for historical flows and loads analysis. However, due to significant rainfall between January and March in 2023, the selected PH flow accounts for peak wet weather flows during that time. The historical influent flow and pollutant loading data for the various averaging periods is summarized in Table 2.

Table 2 Historical Flows and Loads from 2017- March 2023

Parameter		2017	2018	2019	2020	2021	2022	Jan-Mar 2023	Selected (6-yr Avg. or Max)
AA	Flow (MGD)	0.21	0.19	0.21	0.20	0.19	0.20		0.20
	BOD Loading (ppd)	610	650	560	680	730	640		650
	TSS Loading (ppd)	650	660	650	690	640	630		660
	TKN Loading (ppd-N)	110	90	90	100	130	130		110
ADWF	Flow (MGD)	0.20	0.20	0.20	0.21	0.19	0.20		0.20
AWWF	Flow (MGD)	0.25	0.18	0.23	0.18	0.20	0.19		0.21
MM	Flow (MGD)	0.30	0.21	0.30	0.24	0.22	0.23	0.39	0.39 ¹
	BOD Loading (ppd)	680	760	700	880	980	810		980
	TSS Loading (ppd)	770	800	850	890	820	880		900
MW	Flow (MGD)	0.39	0.28	0.34	0.27	0.32	0.29	0.46	0.46 ¹
	BOD Loading (ppd)	830	820	850	1,060	1,090	790		1,100
	TSS Loading (ppd)	860	850	870	1,080	910	880		1,090
MD	Flow (MGD)	0.52	0.46	0.45	0.32	0.64	0.54	0.74	0.74 ¹
	BOD Loading (ppd)	1,080	990	880	1,300	1,340	1,040		1,340
	TSS Loading (ppd)	1,250	1,150	1,130	1,350	930	1,240		1,350
PH	Flow (MGD)	1.08	0.67	0.96	1.14	1.12	1.21	1.35	1.35 ¹
Min Day	Flow (MGD)	0.15	0.16	0.15	0.15	0.14	0.12		0.12

^[1] Selection based on flows from January 2023 through March 2023.

Historical flows and loads were used to project future flows and loads through a 20% increase of the number of housing units. The District's historical and future service area is almost exclusively domestic; therefore, the increase in housing units was proportionally applied to historical flows and loads to calculate the projections. The exception to this projection methodology is the PH flow, which was selected based on the PH flow calculated from the equalization volume analysis that is captured in this Report.

The selected design flows and loads that the WRRF treatment processes will be designed against are summarized in Table 3. These flows and loads align with the projected flows and loads for AA, MM, MW, ADWF, and AWWF conditions. MW flow conditions represent the flow and load design condition for the treatment processes downstream of the Headworks. Flow parameters above the MW design condition apply specifically to the hydraulic design of the Headworks, Influent Splitter Box, and Equalization Basin, which are upstream of the MBR.

Table 3 Design Flows and Loads

Parameter	Units	AA	MM	MW	MD	ADWF	AWWF	PH	Min Day
Flow	MGD	0.24	0.46	0.55	0.88	0.24	0.25	1.39	0.15
BOD	mg/L	390	305	290	223	-	-	-	
	ppd	780	1,170	1,330	1,640	-	-	-	
TSS	mg/L	395	289	294	215	-	-	-	
	ppd	790	1,110	1,350	1,580	-	-	-	
TKN	mg/L-N	70	52	50	38	-	-	-	
	ppd-N	140	200	230	280	-	-	-	
Ammonia	mg/L-N	50	39	35	27	-	-	-	
	ppd-N	100	150	160	200	-	-		

Implementation and Next Steps

This Report describes the current design approach and site and process design that will be advanced into final design. This Report represents 60% Design Report TSO milestone action, which is to be submitted to the CCRWQCB by November 15, 2023. In addition to CCRWQCB TSO R3-2022-0046 milestone requirements, the progression of the design and construction schedule for the WRRF Upgrades is driven by or dependent on the following factors:

- USDA review of design deliverables and approval of design documents against USDA Water & Waste Disposal Loan & Grant Program requirements.
- Equipment procurement for long-lead equipment and project bidding schedules.
- Constructability of the WRRF Upgrades and reasonable expectation of construction timelines for the nature of the improvements being constructed.
- Startup and commissioning requirements for an upgraded WRRF.

The timelines and critical path relationships between these activities were considered in the development of a design and construction schedule that incorporates these elements, which is captured in Figure 3.

The next project milestone per the TSO is completion and submission of the Final Design Report (e.g., plans and specifications) to the CCRWQCB by April 15, 2024. Prior to completion of the Final Design Report, there are several milestones that will be tracked internally by the District and WSC to advance the project:

- Incorporation of USDA review comments on the Draft Preliminary Engineering Report (PER) and submission of the Final PER to secure funding commitments from USDA.
- Completion of the 100% design by March 2024.
- Adoption of the District's sewer service rate increases to support funding of the project.

Permitting and environmental efforts with County of San Luis Obispo entities and state and federal organizations, respectively, are also currently underway to advance the WRRF Upgrades toward implementation.

Heritage Ranch WRRF Improvements Schedule



Permitting

ROWD Application: March 2022 – June 2022
 TSO Renewal: July 2022 – November 2022
 NPDES Permitting: April 2025 – December 2026

Design

PDR: April 2022 – December 2022
 60% Design: October 2023
 Final Design: January 2023 – December 2024
 Equipment Procurement: April 2024 – September 2024
 Bidding and Award: January 2025 – April 2025

USDA

PER: March 2024
 USDA PER Review: April 2024 – July 2024
 USDA Design Document and Equipment Procurement Review:
 April 2024 – January 2025

Construction

WRF Improvements: March 2025 – January 2027
 30% Construction Complete: October 2025
 80% Construction Complete: October 2026

Commissioning

Upgraded WRF Operations:
 February 2027 – September 2027

Figure 3 WRRF Upgrades Design and Construction Schedule

Completion of this PDR marks a 60% design progression which sets the basis of design for nearly all aspects of the WRRF Upgrades. The proposed WRRF Upgrades described in this PDR will be carried forward into a detailed design with subsequent 90% and 100% design deliverables prior to preparing bid set documents for public bid.

1.0 Introduction

This chapter introduces the WRRF Upgrade project to highlight the project drivers, history and context of the existing facility, preliminary design work performed to date, the scope of the upgrades, and an overview of the Program Charter.

IN THIS SECTION

- Background
- Existing Facilities
- Prior Preliminary Design Work
- Scope of Upgrades
- Program Charter

1.1 Background

Heritage Ranch Community Services District (District) is located in the northern part of San Luis Obispo County (SLO County), east of Lake Nacimiento and south of the Nacimiento River. The District provides municipal services to most of the Village of Heritage Ranch, including wastewater collection and treatment. The District owns and operates the collection system pipelines and lift stations, and the centralized wastewater treatment plant (WWTP) located at 4870 Heritage in Paso Robles, California. Wastewater flows are primarily domestic with a small fraction of commercial sources from a local shopping center. The existing WWTP is an aerated pond system that produces disinfected secondary treated effluent that is discharged to an ephemeral drainage way which is tributary to the Nacimiento River.

In 2017, the District renewed their Waste Discharge Requirements (WDR) for their WWTP with the Central Coast Regional Water Quality Control Board (CCRWQCB). The updated WDR (Order No. R3-2017-0026) included more stringent limits for total recoverable copper and un-ionized ammonia, as well as a 10 mg/L-N nitrate limit.

Recognizing that the District had not been meeting existing WDR effluent requirements and could not immediately meet the new effluent requirements through operational optimization or minor changes to their existing treatment system, the District requested and received Time Schedule Order (TSO) No. R3-2018-0011 in 2018. Following discussions with the CCRWQCB and preliminary engineering studies for upgrades to their WWTP, the District requested and received a TSO extension that was adopted October 14, 2022 (TSO R3-2022-0046). The TSO extension requires full compliance with effluent requirements from WDR R3-2017-0026 by September 30, 2027. TSO requirements and milestone requirements can be referenced in Appendix A.

Through preliminary engineering studies and operational evaluations, it was determined significant upgrades to the District's WWTP are required to meet the WDR permit limits. The driver for the project is thus twofold:

1. the existing WWTP cannot be easily modified or operationally optimized to meet permit limits, specifically un-ionized ammonia, nitrate, and copper; and
2. the District must produce treated effluent that can consistently and reliably meet permit limits by September 30, 2027 per the TSO.

The resultant project is an upgrade of the District's WWTP to a water resource recovery facility (WRRF) capable of nitrification and denitrification (WRRF Upgrades), which is described in this 60% Design Report (Report).

1.2 Existing Facilities

The existing WWTP was originally constructed in 1978, consisting of an in-series aerated pond system with two ponds, an effluent pump station, on-site chlorination with sodium hypochlorite, and dechlorination with sodium bisulfite at the effluent disposal site. The effluent disposal site, which is approximately 3.5 miles from the WWTP, also includes an effluent storage pond (Pond

3), sand filters for effluent polishing and dechlorination with sodium bisulfite. This section summarizes the current operation and purpose of the existing facilities. Chapter 2.0 includes site maps illustrating these facilities and their proposed use or modifications for the WRRF Upgrades.

1.2.1 Aerated Ponds

Pond 1 and Pond 2 are lined ponds operated in-series to provide biochemical oxygen demand (BOD) removal and partial nitrification. Raw influent from the collection system enters Pond 1 through three (3) influent force mains (Figure 4) and flows into Pond 2 by gravity. Pond 2 effluent flows by gravity to the effluent pump station wet well. One of the lift station force mains can bypass Pond 1 through an 8-inch pipeline that terminates at Pond 2. Physical and design characteristics of Pond 1 and Pond 2 are summarized in Table 4.



Figure 4 Pond 1 and Influent Force Mains

Table 4 Physical and Design Characteristics of Aerated Ponds

Pond 1	
Type	Partially Aerated, Lined
Surface Area	1.25 acres
Total Depth	13 feet
Normal Operating Depth	11 feet
Side Slope	3:1 H/V
Total Volume	3.6 MG
Operating Volume	2.8 MG
Aeration Type	Mechanical Surface
Number of Aerators	3
Total Horsepower	57.5 (40, 10, 7.5) HP
Pond 2	
Type	Partially Aerated, Lined
Surface Area	0.75 acres
Total Depth	14 feet
Normal Operating Depth	12 feet
Side Slope	3:1 H/V
Total Volume	2.0 MG
Operating Volume	1.7 MG
Aeration Type	Mechanical Surface
Number of Aerators	1
Total Horsepower	10 HP

1.2.2 Effluent Pump Station and Disinfection

Pond 2 effluent is pumped through an 8-inch force main that is injected with sodium hypochlorite for disinfection before transitioning to a 6-inch pipeline near the WWTP property line. Sodium hypochlorite is fed through an on-site storage tank and peristaltic pump into a dosing point at a vault along the access road to the WWTP. The force main extends 3.5 miles to the disposal site. The effluent pump station includes two (2) 25-hp vertical turbine pumps. Debris and rags from the upstream pond system can cause clogging of the pump suction that must be removed. The pumps are sized to convey up to 536,000 gallons per day (gpd), equal to 186 gallons per minute (gpm) or 268,000 gpd per pump (1). The existing pumps do not have reliable capacity (with one pump offline) to convey the rated design capacity of the existing WWTP of 400,000 gpd. Figure 5 shows a photo of the existing effluent pump station and Figure 6 shows the existing sodium hypochlorite storage tank and the shed that houses the chemical feed pump.



Figure 5 Existing Effluent Pump Station



Figure 6 Existing Disinfection Facility

1.2.3 Pond 3 Effluent Storage Pond

Flow from the effluent pump station is either directed to the Pond 3 (Figure 7) or to the sand filters. Pond 3 ranges from approximately 13 to 16 feet deep and has an approximate storage capacity of 6.5 MG. During the late spring, summer, and early fall, the flow is sent to Pond 3 upstream of the sand filters for effluent polishing process and storage prior to disposal. From late fall months through early spring months, effluent from Pond 3 exceeds effluent requirements for pH and suspended solids likely due to algae growth and thus flow bypasses Pond 3 toward the sand filters.



Figure 7 Pond 3 Effluent Storage Pond

1.2.4 Sand Filters

The effluent disposal site includes three (3) sand filters that provide suspended solids removal (Figure 8). The equipment includes a spray-type filter feed system to aerate the water and distribute it across an 18" deep bed of sand media, segmented into three (3) filter areas. A gravel underdrain collects the filtrate and conveys it to the outfall.



Figure 8 Existing Sand Filters

1.2.5 Dechlorination and Outfall

From the filter underdrain, treated water discharges into an ephemeral drainage (Figure 9). Treated wastewater is dechlorinated using sodium bisulfite tablets in the filter underdrain before reaching the outfall (Figure 10). The effluent in the ephemeral drainage way flows approximately 1.5 miles where it then percolates into the ground. During high flow periods, the discharge could potentially keep flowing toward the Nacimiento River which is 4.2 miles from the discharge point.



Figure 9 Existing Outfall



Figure 10 Existing Dechlorination Point

1.3 Prior Preliminary Design Work

The District hired MKN to prepare a Recycled Water Study (published January 2017) to evaluate potential recycled water uses within the District's service area, and a Preliminary Engineering Memorandum (PEM) to evaluate upgrades to the WWTP that would allow the District to meet the new regulatory effluent limits (published April 2021).

The Recycled Water Study identified one potential user with an average day demand of 63,000 gpd. Based on the project cost and lack of interested recycled water customers, the District did not identify recycled water as a key driver for upgrades to the WWTP.

MKN's PEM evaluated four (4) treatment alternatives ranging from modifications to the existing pond system to installation of package systems to replace the pond treatment system. The PEM identified a packaged membrane bioreactor (MBR) system as the preferred alternative for WRRF Upgrades based on the following criteria:

- Impacts to existing treatment facilities
 - Footprint
 - Process redundancy upgrades
- Expected effluent water quality
- Sludge handling
- Capital, operation, and maintenance costs

Table 5 Alternatives from 2021 Preliminary Engineering Memorandum (2)

Alternative	Description
1	Modifications to the Existing Pond System with Diffused Aeration And Bioreactor
2	Conversion of the Existing Pond System to an Extended Aeration System
3A	Installation of a Packaged Activated Sludge System
3B	Installation of a Packaged Membrane Bioreactor System

Following completion of the PEM, the District procured WSC as their design engineer for the WRRF Upgrades. One of the initial tasks of the design scope was a design confirmation to compare the preferred alternative for a packaged MBR system against a site built MBR facility, the approach and results of which are captured in Chapter 3.0.

1.4 Scope of Upgrades

The WRRF Upgrades and WSC's proposed design scope include construction of the following facilities:

- **Headworks** facility consisting of coarse screening.
- **Influent Splitter Box** to intercept and combine raw influent flows from the three (3) terminal lift stations in the collection system and convey wastewater to either the Equalization Basin or the Headworks facility.
- **Equalization Basin** to attenuate peak flows to the treatment process and provide diurnal flow and load equalization to provide more stable treatment.
- **Packaged MBR** activated sludge system to provide full nitrification-denitrification and direct filtration as well as pre-membrane fine screening.
- **Effluent and Utility Water Pump Station** to provide effluent pumping to the discharge location, utility water supply to in-plant uses, and provisions for future recycled uses.
- **Chemical Facility** for storage of chemicals required for MBR cleaning and effluent disinfection.
- **Dewatering Facility** to provide dewatering of WAS from the MBR system and short-term storage of dewatered solids within a building.
- **Electrical Building** to house motor control centers (MCC) and power distribution system.
- **Standby Generator** to provide backup power to operate the WRRF.

Existing Maintenance Building Retrofits to provide space for operator workstations, supervisory control and data acquisition (SCADA) interfaces, and bathroom facilities for onsite operations and maintenance staff.

1.5 Program Charter

The start of the WRRF Upgrades design phase represents a significant milestone of the District's commitment to the scope of the upgrades and the overall program for implementation. To establish a clear and consistent vision and mission, and a set of goals and objectives, the District project staff, the District Board, and WSC participated in a Program Chartering Workshop on November 4, 2021. The purpose of the Program Chartering Workshop was to develop a Program Charter that would be adopted by all its contributors and project staff to:

- Define vision, goals and objectives of the Program including an articulation of key success factors.
- Describe Program benefits, and what defines Program success.
- Establish the Steering Committee team including structure, roles and responsibilities, decision authority, and define subcommittees.
- Identify the key Program stakeholders, including identification of key stakeholders
- Describe the desired values and norms for the Program.
- Set a framework for encouraging collaboration, transferring knowledge, resolving disputes, avoiding scope creep, and measuring progress.
- Establish a mechanism for periodic review and/or update of the Program Charter.

The Program Charter sets the tone for all work to be performed on the Program and serves as a valuable reference for those contributing to the Program's success. Key decisions related to design approach can be reflected upon the Program Charter to support evaluation of those decisions.

The Vision and Mission of the WRRF Upgrade Program, as developed by the District Board, District staff, and WSC at the Program Chartering Workshop, are:

Vision: Provide cost-effective, adaptable wastewater treatment that achieves reliable compliance and sustainably meets the long-term needs of the community and environment.

Mission: Deliver a new Water Resource Recovery Facility that exceeds regulatory requirements and positions the District to maximize the beneficial use of recycled water.

The District Board adopted the Program Charter on November 18, 2021, which can be referenced in Appendix B.

2.0 Site Planning Evaluation

The Site Planning evaluation defines the availability, constraints, considerations, and District preferences for utilizing areas and existing infrastructure at the WRRF site and the effluent discharge location.

IN THIS SECTION

- Approach
- Evaluation
- Effluent Disposal Site
- Conclusions

2.1 Approach

In December 2021, WSC and HRCSD Operations Staff conducted a site walk at the WWTP to develop the vision and preferences for use of areas throughout the WWTP site, as well as document WWTP site constraints, considerations, and planned future operation of existing facilities. WSC and the District discussed and determined what infrastructure is to remain or be removed, and which areas of the site were potentially available for future improvements. Site opportunities and constraints were identified and presented by the WWTP operators, with an understanding of what infrastructure is to be constructed for the WRRF Upgrades.

Area designations within the WWTP site were used to differentiate facilities by operational functionality and purpose. Areas are segmented to provide a spatial representation of similar process or facility locations to aid in locating future upgrades or retrofits in a manner that minimizes yard piping length, electrical power feed distance and pumping between unit processes. The area designations of the existing facilities are shown in Figure 11, and defined below:

- **Power:** Consists of the solar panels, the area reserved for future solar panel expansion, the main switchgear, and the electrical transformer.
- **Processes:** Consists of two treatment ponds and the effluent pump station.
- **Operations & Maintenance (O&M):** Consists of the Storage Building, Materials Storage, Maintenance Building, Chlorine Chemical Storage, Storage Sheds, Fuel Tanks, and the Laboratory

Based on the discussions with District staff and operators during the site walk and consideration of the WRRF Upgrades scope, areas were categorized as either “to remain”, “to repurpose”, or “to be removed”. Areas to remain will be preserved for operation or use after the upgrades are implemented, areas to repurpose will be upgraded or modified to serve a new purpose, and areas to be removed will be demolished or relocated as part of the WRRF Upgrades. Areas to be removed create additional available space for WRRF Upgrades infrastructure.

A site survey of the WRRF site was also performed to obtain utility locations, site topography and key elevations, and improved equipment and infrastructure location accuracy. This site survey can be referenced in Appendix C.

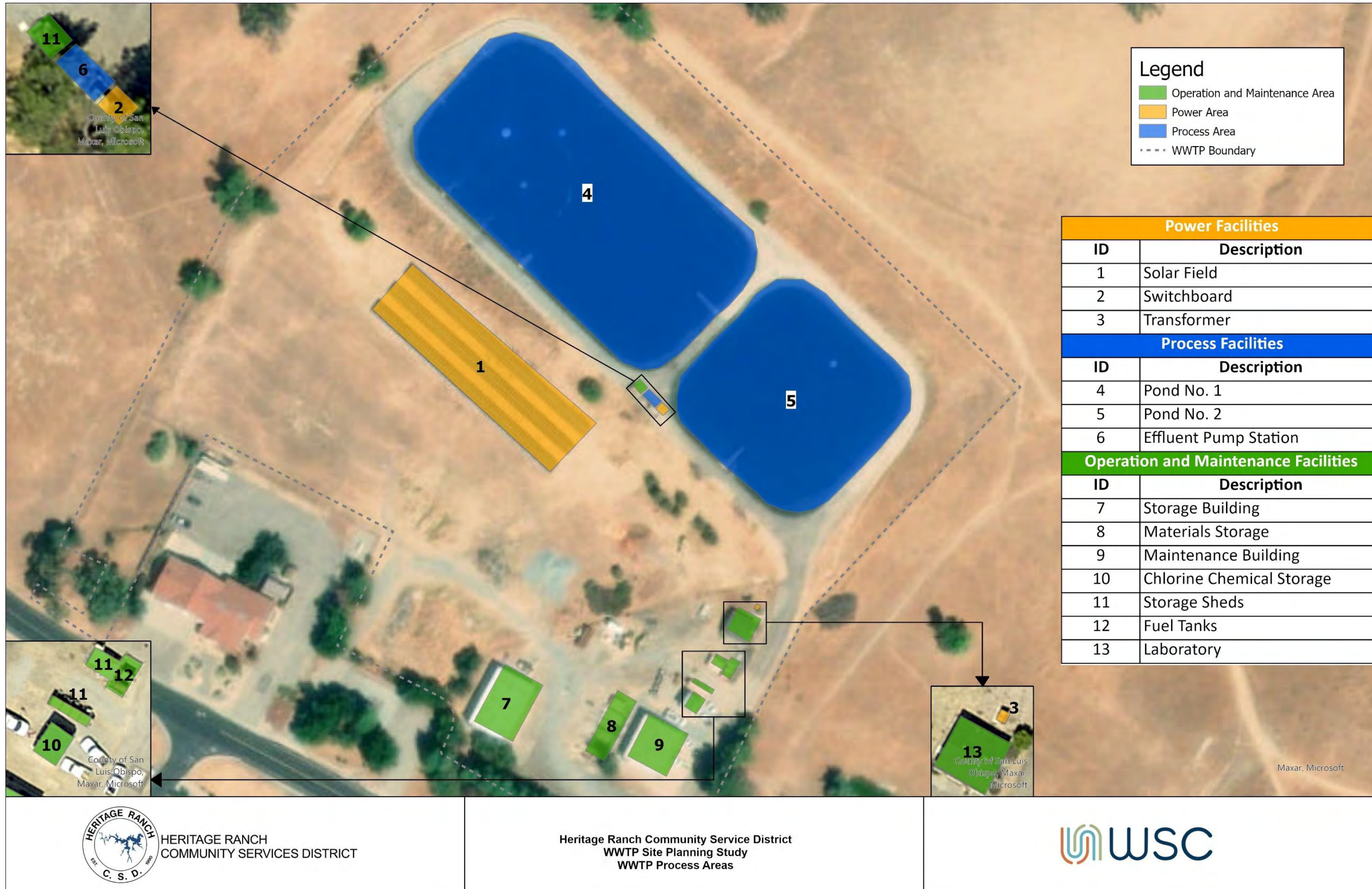

Figure 11 WWTP Area Designations and Process Areas

2.2 Evaluation

WSC analyzed the information collected from the site walk with District staff and the site survey results to define site availability, opportunities and constraints for each Process Area, as well as site planning decisions for the existing areas. Table 6 includes these results by Process Area, categorized by Area Designation, and Figure 12 illustrates the site planning decisions. Figure 13 summarizes the available space for the WRRF Upgrades and the area to be preserved for future expansion of the Solar Field.

In addition to the information provided in Table 6, general conclusions for various site planning elements are described below.

- **Siting of Upgrades:** As illustrated in Figure 13, there is sufficient available space for site upgrades at the existing site. The two larger areas available for upgrades are south or northwest of the existing Solar Field. The area to the south of the Solar Field is closer to existing facilities and utilities but presents some constraints and challenges for construction due to several utility conflicts in the area. The area to the northwest of the Solar Field presents challenges for incorporating hydraulic controls for flow equalization without pumping or needing to construct in the area of the existing influent force mains; furthermore, this area includes the neighboring fire station and proposed future residential development north of the site.
- **Site Constraints:** The key constraints are maintaining operation of the existing treatment ponds through construction and constructing new transformer and switchboard equipment while keeping the existing site operational and avoiding utility conflicts. Additionally, there is an existing household hazardous waste trailer in the middle of the site that will be relocated toward the roundabout driveway off Heritage Road, southwest of the new Operations Building and northwest of the Storage Building, which limits available area in that location.
- **Utility Access Points and Rerouting:** Utility access points and locations can be referenced in Appendix C, which includes a full-size exhibit of the known underground utilities at the HRCSD WWTP. All utilities that serve Process Area functions are located underground in buried trenches or within electrical ductbanks throughout the site. Electrical, high pressure gas, and water connections are between the existing treatment ponds and the available spaces for WRRF Upgrades. Regardless of where the WRRF Upgrades are sited, there are underground utilities that will require relocation or coordination with new utilities.

Table 6 Site Planning Notes and Decisions

Process Area (ID)	Planned Future Uses/Projects	Constraints	Site Planning Decision
Area Designation: Power Facilities			
Solar Field (1)	The solar power system was recently constructed onsite as a sustainable energy resource for the facility. There are plans to expand on this in the future with a similarly sized solar array to the southwest of the existing solar array.	The electrical feed between the transformer and the solar panels, which follows a direct line between the two, may interfere with underground utilities or construction in that area.	Remain
Switchgear (2)	As discussed in Section 5.5, the existing switchgear is too small for the loads of the new WRRF Upgrades and will need to be replaced with a larger switchgear.	Existing switchgear does not have enough capacity to serve future loads. Switchgear is currently connected to existing solar field.	Remove
Transformer (3)	As discussed in Section 5.5, the existing transformer is too small for the loads of the new WRRF Upgrades and will need to be replaced with a larger transformer.	Existing transformer does not have enough capacity to serve future loads. Transformer is currently connected to existing solar field.	Remove
Area Designation: Process Facilities			
Pond 1 (4)	Continue operation during construction to provide treatment. Repurpose as materials storage following implementation of WRRF Upgrades.	The existing treatment processes must stay online during construction to maintain compliance with the discharge permit.	Repurpose
Pond 2 (5)	Continue operation during construction to provide treatment. Repurpose as Equalization Basin following implementation of the treatment process upgrades.	The existing treatment processes must stay online during construction to maintain compliance with the discharge permit.	Repurpose
Effluent Pump Station (6)	Continue operation during construction to provide conveyance of treated effluent. A new effluent pump station will be constructed as part of the WRRF Upgrades.	The existing treatment processes must stay online during construction to maintain compliance with the discharge permit.	Remove
Area Designation: Operation and Maintenance Facilities			
Storage Building (7)	Continue to use for equipment storage.	No constraints identified since the facility will remain.	Remain
Materials Storage (8)	Continue to use for materials storage.	No constraints identified since the facility will remain.	Remain
Maintenance Building (9)	Continue to use for maintenance space and equipment storage. Some of the existing purposes, such as use for operator workspace and restroom facilities, will be retrofitted or expanded to provide operator workstations, sanitary facilities, and locker space.	No constraints identified since the facility will remain.	Remain
Chlorine Chemical Storage (10)	This is currently in poor condition and thus needs to be removed. A new chemical storage area will be relocated to serve new processes.	The Chlorine Chemical Storage area is in a location that will be used for future construction. Temporary chlorine dosing operations will be needed while construction takes place in that footprint.	Remove
Storage Sheds (11)	The storage shed spaces will not needed and will be removed.	No constraints identified.	Remove
Fuel Tanks (12)	Continue to use as storage for fuel.	No constraints identified since the facility will remain.	Remain
Laboratory (13)	Continue to use as a laboratory.	The laboratory has an existing sewer pipeline that was not identified or readily located during the site survey. Locating this line may require potholing or investigation during early construction grading efforts.	Remain

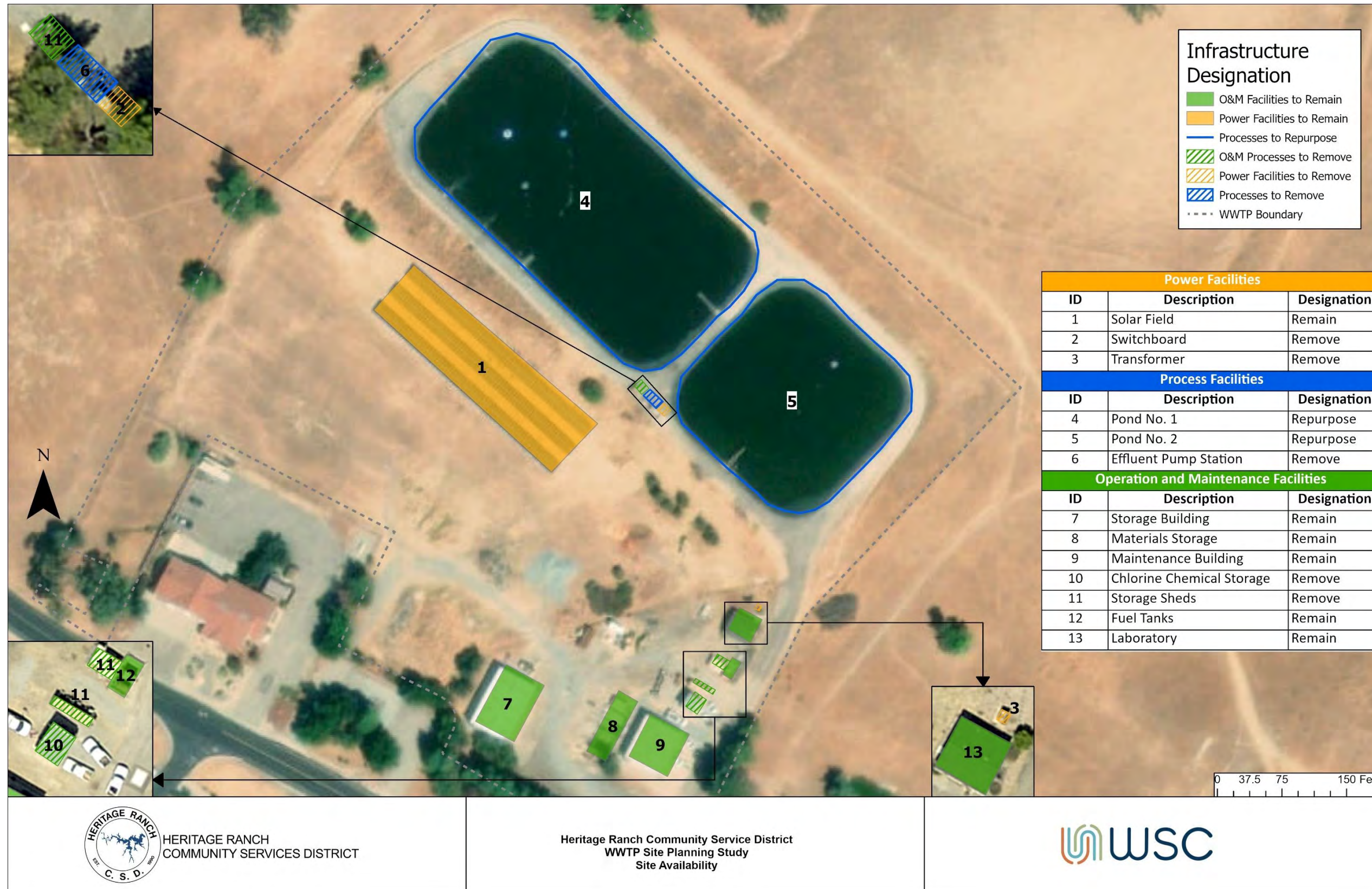

Figure 12 WWTP Site Planning Decisions and Availability

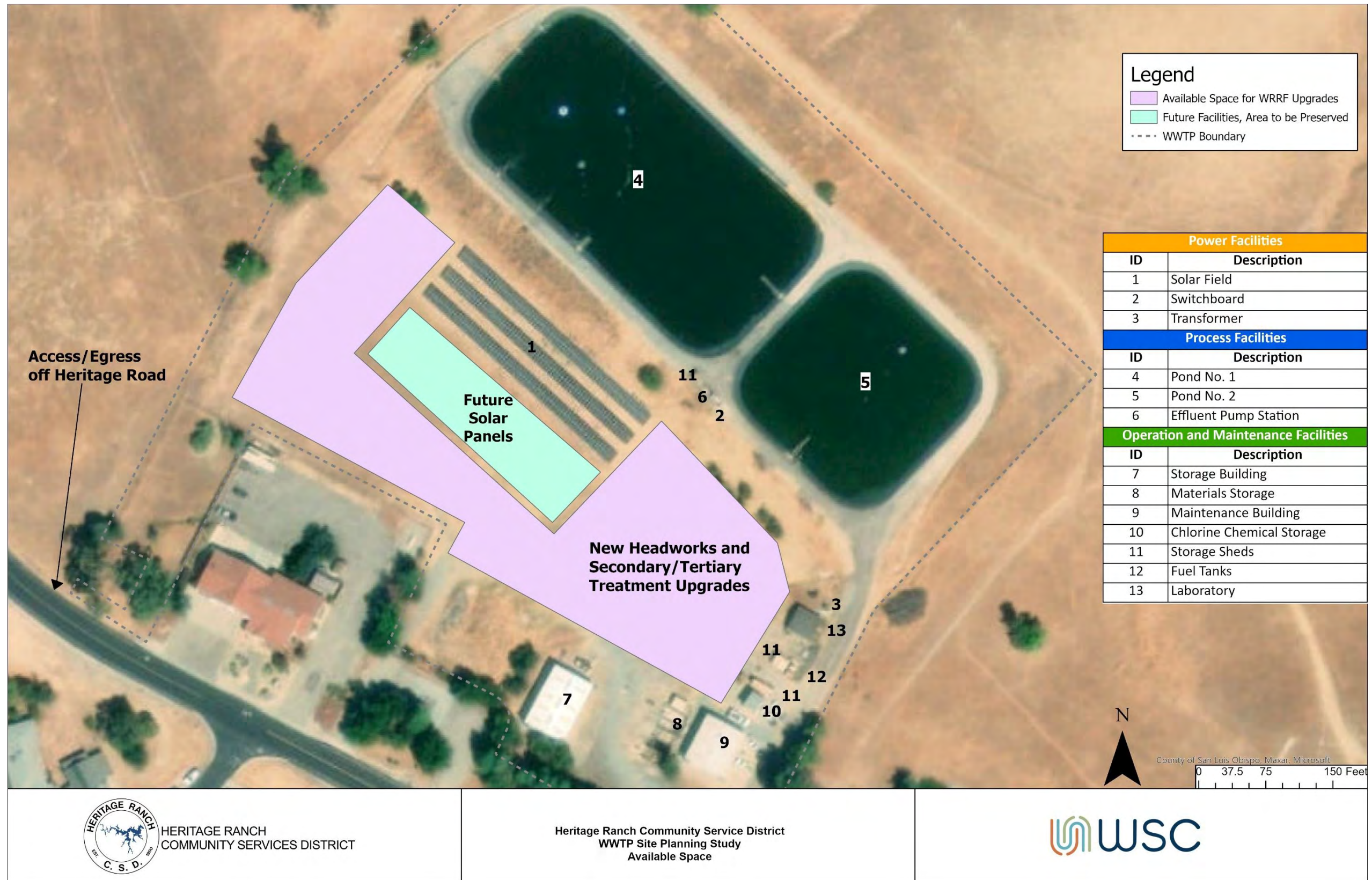

Figure 13 Available Space for WRRF Upgrades

2.3 Effluent Disposal Site

Effluent from the WWTP is conveyed to the Effluent Disposal Site located off Nacimiento Lake Drive, which is approximately 2.5 miles east of the WWTP site. Existing treatment facilities at the Effluent Disposal Site include the following:

- **Pond 3:** An earthen dammed pond that provides storage and polishing for effluent prior to gravity flow to the Sand Filters.
- **Sand Filters:** Three (3) sand filters located at grade fed by a spray system that provide filtration of effluent prior to dechlorination and discharge. Underdrains from the filter convey the filtered effluent to the dechlorination piping by gravity.
- **Dechlorination:** A standpipe system near the discharge location that provides dechlorination of the effluent via sodium bisulfite tablets.
- **Discharge Location:** Effluent pipeline that discharges to an ephemeral drainage way, tributary to the Nacimiento River.

Pond 3 will remain in place following the WRRF Upgrades. The Sand Filters will be bypassed for effluent disposal since additional treatment will not be required. The Dechlorination facility will be replaced with liquid sodium bisulfite storage, a chemical dosing system to quench residual chlorine in the effluent, and on-line instrumentation to monitor residual chlorine in the effluent prior to discharge. The Discharge Location will remain as-is with minor improvements for easier effluent sampling. There is adequate space at the Effluent Disposal Site for the Dechlorination facility improvements with no significant constraints outside of the lack of existing electrical power. The planning and design of these improvements will be captured outside of this PDR.

2.4 Conclusions

Key results of the Site Planning Evaluation include identification of constructability and sequencing constraints to consider during design and available space for the WRRF Upgrades. Based on the results of the Site Planning Evaluation and review of the Site Survey, the available space south of the existing Solar Fields is most favorable for siting of the WRRF Upgrades for the following reasons:

1. This location allows for integration into the existing system and utility locations with minimal yard piping and electrical service runs.
2. It provides more constructable options for intercepting the influent force mains while maintaining pressure from the collection system, which provides better opportunities for gravity flow downstream of an Influent Splitter Box.
3. It is located away from the neighboring fire station facility and the future housing development that may be located directly north of the northwest site boundary.
4. Existing trees and buildings at the south and southwest end of the site provide screening from the public roadway of new WRRF facilities.

5. When considering the location of the Solar Field expansion area, it provides the largest contiguous area for siting of improvements.

Following the District's direction to use this area of the site for the WRRF Upgrades location, WSC prepared a conceptual site plan of the proposed upgrades as a basis for the site design, as illustrated in Figure 14. This site plan reflects approximate footprints of all the process units, buildings, and supporting facilities. Physical separations between facilities based on CBC and CFC requirements for hazardous material storage and hazardous area classifications based on NFPA 820 were incorporated into the site layout. The proposed layout allows for gravity flow from the beginning of the process to the end of the MBR process and provides sufficient access-egress for equipment access, maintenance, chemical deliveries, and vehicle access. The site layout does not mitigate all site constraints such as utility conflicts and the need to operate the existing facility through construction, but it provided significant benefits over the other potential on-site location.

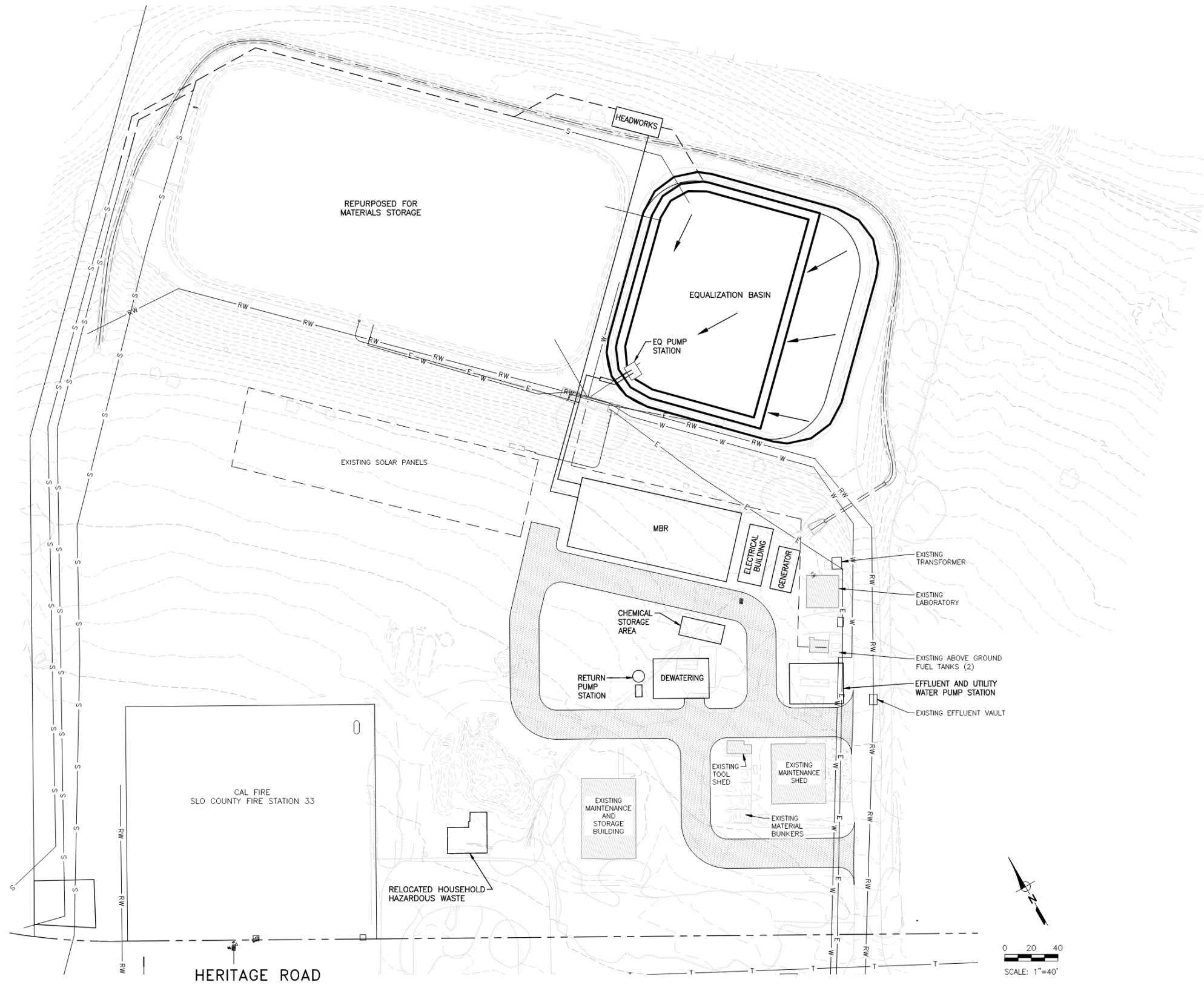

Figure 14 Site Plan

3.0 Design Confirmation

WSC completed a Design Confirmation task to evaluate alternatives for a packaged MBR system against a site built MBR for the WRRF Upgrades. The alternatives were evaluated on both economic and non-economic criteria. The alternatives analysis was presented to the District Board for selection of the preferred alternative for the WRRF Upgrades.

IN THIS SECTION

- Approach
- Alternatives Evaluation
- Recommendation and Outcome

3.1 Approach

Early in the design phase, WSC discussed the results of the previously completed PEM for the WRRF Upgrades with the District and identified advantages of a site built MBR over a packaged MBR system that could be realized at a comparable cost. The purpose of the design confirmation task was to confirm which MBR system provides the best economic and non-economic advantages based on an alternatives analysis. The evaluation included a conceptual design for each alternative consisting of site layouts, hydraulics analysis, equipment requirements, and an Association for the Advancement of Cost Engineering (AACE) Class 4 cost analysis.

WSC defined two alternatives, the (1) Packaged MBR, and (2) Site Built MBR based on the project elements outlined in Table 7. Key differences in project elements include the following:

Equalization Basin Pump Station: Pumping of equalized flows is required for the Packaged MBR alternative due to the height of the packaged system which must be installed at grade and therefore has a higher initial hydraulic grade than the Site Built MBR which can be partially buried.

Dewatering Building Odor Control: The footprint of the Dewatering System for the Packaged MBR alternative was much larger and would have required a much larger building than the Dewatering System for the Site Build MBR alternative.

WAS Storage: WAS Storage for the Packaged MBR is included with the Dewatering System packaged system whereas the Site Built MBR alternative includes a constructed WAS storage tank.

Table 7 Project Elements of MBR Alternatives

Project Element	Packaged MBR	Site Built MBR
Headworks - Coarse Screens	✓	✓
Headworks - Fine Screens	Packaged with MBR	Constructed
Headworks - Grit Removal	Packaged with MBR	Constructed
Influent Splitter Box	✓	✓
Equalization Basin Improvements	✓	✓
Equalization Basin Pump Station	✓	
MBR	Packaged Unit	Constructed
Dewatering System	Packaged with MBR	Constructed
Dewatering Building & Odor Control		✓
WAS Storage	Packaged with MBR	Constructed
Chemical Facility	✓	✓
Effluent & Utility Water Pump Station	✓	✓
Operations Building	✓	✓

3.2 Alternatives Evaluation

The alternatives evaluation of the MBR alternatives consisted of the following main steps:

- Development of preliminary design criteria.
- Vendor outreach for headworks, MBR, and dewatering system equipment.
- Prepared conceptual site layouts for each alternative, which included assessment of hydraulic, electrical, supporting facility, operation, and maintenance requirements.
- Development of AACE Class 4 cost estimate and evaluation of non-economic criteria.

3.2.1 Design Criteria

Design criteria for this analysis included redundancy criteria, flow requirements, pollutant loading, and effluent criteria based on the design phase work performed up to the point the analysis was performed. The following criteria was provided to all vendors:

- Design Coarse Screens for Peak Hour flow of 1.7 MGD with a 1 + 1 configuration (1 duty, 1 standby).

- Design Grit Removal, Fine Screens, and MBR for Max Day flow of 0.95 million gallons per day (MGD) and annual average (AA) flow of 0.30 MGD.
- Membrane tank redundancy in a 2 + 1 configuration (2 duty, 1 standby).
- Process water temperature of 16 – 25-degrees Celsius.
- Effluent Requirements for biochemical oxygen demand (BOD), total suspended solids (TSS), nitrate, and un-ionized ammonia (as summarized in Section 4.1).
- Daily wasting rate of 10,000 gallons per day (gpd) of WAS at 0.5-1.0% solids directly from membrane tanks, with a single dewatering unit.

To provide a direct comparison of costs for buildout treatment capacity, phasing of design or construction for future capacity needs was not considered in this alternatives analysis.

3.2.2 Vendor Outreach

WSC performed vendor outreach for the headworks, MBR, and dewatering system equipment to at least two vendors per system, per alternative. Representative manufacturers and equipment were selected for each alternative, as summarized in Table 8.

Table 8 Representative Manufacturers and Equipment for MBR Alternatives

Project Element	Packaged MBR	Site Built MBR
Headworks - Coarse Screens	Saveco Flo-MultiRake Bar Screen	Saveco Flo-MultiRake Bar Screen
Headworks - Grit Removal	Or-Tec (Supplied by Cloacina, combined system with fine screening)	Saveco SAVI Vortex Grit Separator
Headworks - Fine Screens	Or-Tec (Supplied by Cloacina, combined system with Grit Removal)	Saveco Flo-Drum Rotating Drum Screen
MBR	Cloacina Package MEMPAC-M300 System with Suez ZW500D membranes	Suez ZW500D membranes
Dewatering System	Cloacina Package DRYPAC System with PWTech Volute Dewatering Press	FKC Screw Press

3.2.3 Site Layouts

Site layouts for each alternative were prepared based on process unit footprints and results of the Site Planning Evaluation. The same footprint of the existing WWTP site was used for siting of both alternatives. Figure 15 and Figure 16 show the conceptual site layouts for the Packaged MBR and Site Built MBR alternatives, respectively.

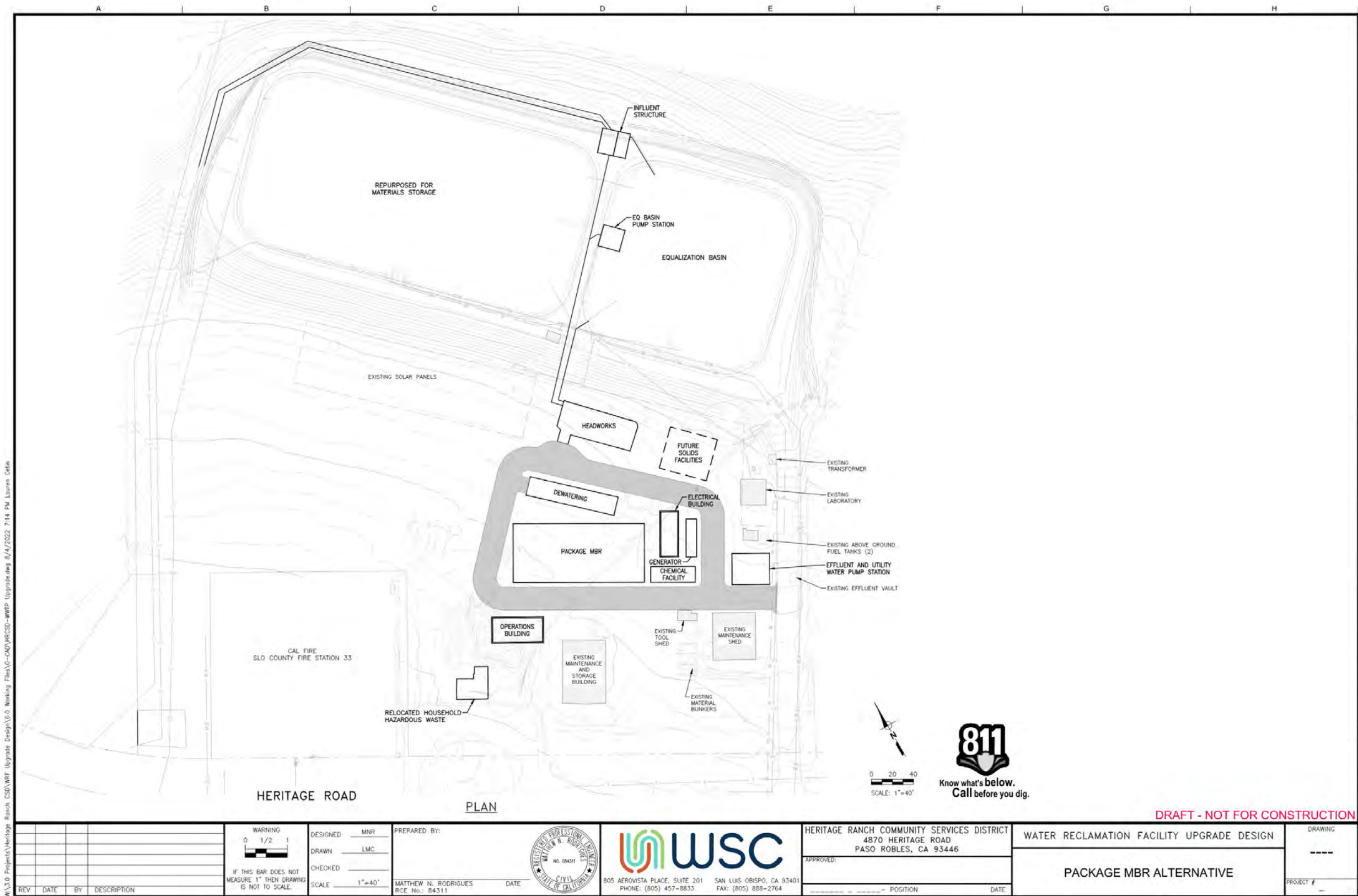

Figure 15 Packaged MBR Alternative Site Layout

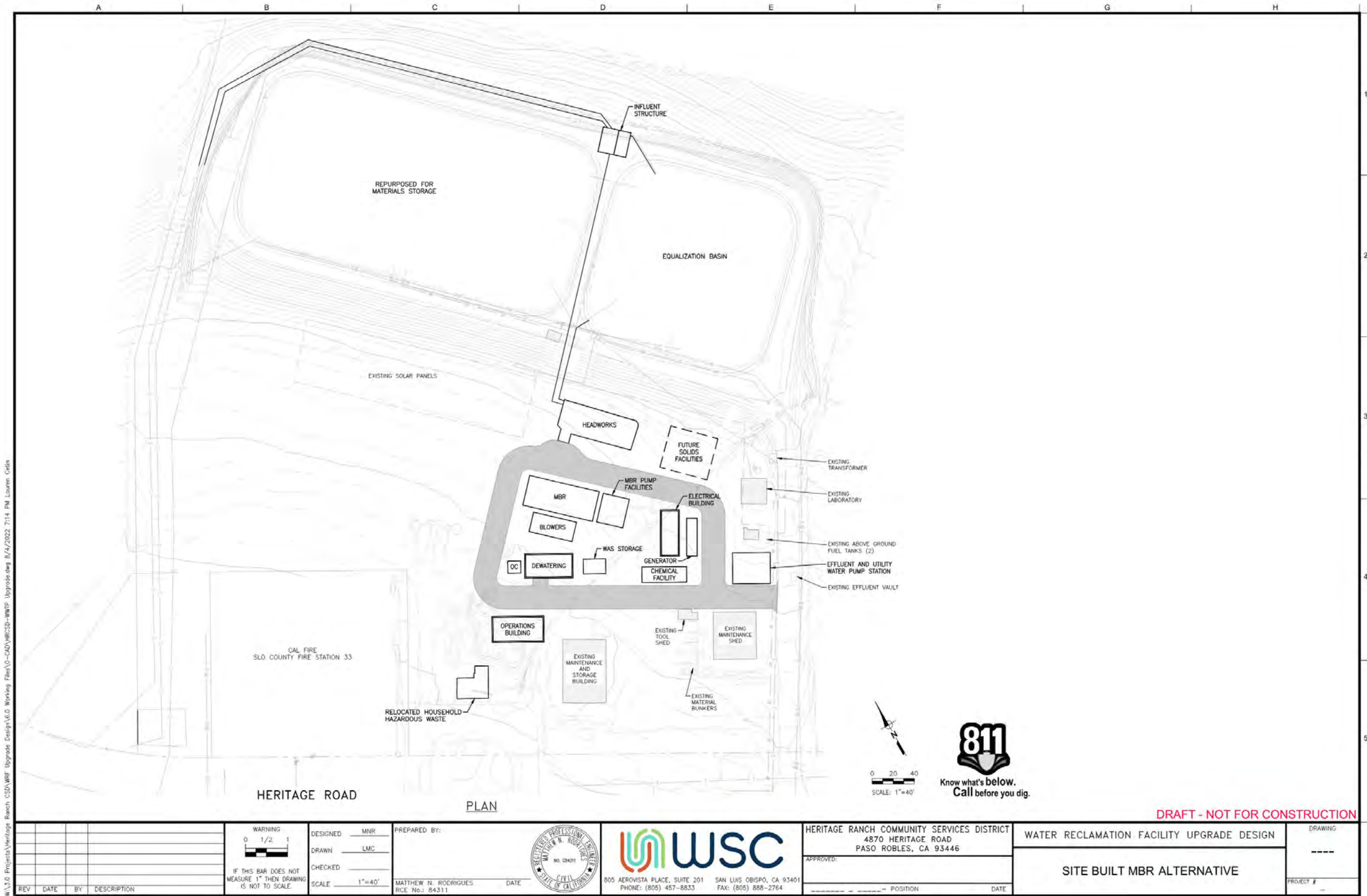

Figure 16 Site Built MBR Alternative Site Layout

3.2.4 Economic Comparison

An AACE Class 4 Cost Estimate was developed for each MBR alternative to represent a “Study or Feasibility Level” analysis with 1-15% Project Definition. The accuracy range of the cost estimates was classified as -15% to +20% accuracy. Costs were quantified in July 2022 dollars using the following data sources:

- Current vendor quotes, inclusive of tax and freight.
- Recent project bids from similar projects or for similar systems and equipment.
- Parametric estimating and escalation from similar projects (completed in last 5 years).
- Unit quantity takeoffs and unit costs.

The cost estimates do not include differences in design phase costs, escalation to midpoint of construction, or third-party value engineering opportunities for design. Annual operations and maintenance (O&M) costs were not included due to the similarities in energy consumption, equipment replacement, chemical use, and other O&M cost factors between the two alternatives. The total capital costs for the Packaged MBR and Site Built MBR alternatives are \$20,752,000 and \$20,028,000, respectively. The main cost differences between the two alternatives were attributable to the main process components, as noted in Table 9.

Table 9 Main Cost Differences of MBR Alternatives

Cost Component	Key Difference in Costs
Influent Splitter Box	The Packaged MBR alternative includes a higher cost due to the need for an equalization basin pump station to pump equalized flows up to an elevated Headworks facility that must sit at a higher grade to flow by gravity into the above grade packaged MBR system. The Site Built MBR alternative does not require an equalization basin pump station since the partially buried MBR allows gravity flow from the Influent Splitter Box and equalization basin through to the MBR tanks.
Headworks	The Site Built MBR alternative includes the coarse screen, grit removal, and fine screening processes which results in a higher cost compared to the Packaged MBR alternative, which only includes the coarse screens.
MBR	The Packaged MBR alternative has a higher cost because it includes the grit removal-fine screen combined process equipment. Also, the base cost for the equipment plus tankage is greater than the base cost of equipment and concrete structure of the Site Built MBR alternative.
Dewatering System	Higher cost associated with Site Built MBR because pre-engineered metal building was applied to design to allow for dewatering system odor control process. The footprint of the Packaged MBR alternative’s dewatering system was too large to accommodate a reasonably sized building.

Table 10 is a legend for the breakdown of subtotal costs that comprise the total capital cost, and Table 11 includes a detailed comparison of the total capital costs for the MBR alternatives.

Table 10 Capital Cost Breakdown

ID	Cost Item	Equal To
A	Process Elements	
B	Subtotal	A
C	Unaccounted for Costs	$B \times 5\%$
D	Contractor Overhead & Profit	$B \times 15\%$
E	General Conditions	$B \times 3\%$
F	Construction Cost Subtotal	$B + C + D + E$
G	Implementation (Admin, ESDC, CM)	$F \times 15\%$
H	Construction Contingency	$F \times 15\%$
I	Total Capital Cost	$F + G + H$

Table 11 MBR Alternative Total Capital Cost Comparison

ID	Cost Item	Packaged MBR	Site Built MBR	Equal To
A	Influent Splitter Box	\$ 570,000	\$ 120,000	
A	Headworks	\$ 755,000	\$ 1,742,000	
A	MBR	\$ 5,610,000	\$ 3,925,000	
A	Dewatering	\$ 888,000	\$ 1,429,000	
A	WAS Storage	\$ -	\$ 194,000	
A	Chemical Facility	\$ 504,000	\$ 504,000	
A	Electrical Building	\$ 1,041,000	\$ 1,041,000	
A	Generator	\$ 558,000	\$ 558,000	
A	Effluent and UW Pump Station	\$ 464,000	\$ 464,000	
A	Operations Building	\$ 1,266,000	\$ 1,266,000	
A	Site Civil and Grading	\$ 398,000	\$ 359,000	
A	Equalization Basin Improvements	\$ 857,000	\$ 857,000	
A	Demolition	\$ 65,000	\$ 65,000	
B	Subtotal	\$ 12,976,000	\$ 12,524,000	Sum of A
C	Unaccounted for Costs	\$ 649,000	\$ 627,000	B x 5%
D	Contractor Overhead & Profit	\$ 1,947,000	\$ 1,879,000	B x 15%
E	General Conditions	\$ 390,000	\$ 376,000	B x 3%
F	Construction Cost Subtotal	\$ 15,962,000	\$ 15,406,000	B + C + D + E
G	ESDC and CM	\$ 2,395,000	\$ 2,311,000	F x 15%
H	Construction Contingency	\$ 2,395,000	\$ 2,311,000	F x 15%
I	Total Capital Cost	\$ 20,752,000	\$ 20,028,000	F + G + H

3.2.5 Non-Economic Comparison

WSC prepared a set of non-economic criteria that was discussed with District staff. Based on engineering judgment and project experience, WSC's preliminary scoring showed the Site Built MBR was at an advantage for the criteria summarized in Table 12. During the presentation of the MBR Alternatives Analysis to the District Board, the District elected to focus on the economic evaluation and to not perform a non-economic scoring comparison. Some of the non-economic comparison was discussed during the discussions with the District Board and staff, but a formal scoring was not attributed to compare the alternatives on this basis.

Table 12 Non-Economic Criteria for MBR Alternatives Analysis

Non-Economic Criteria	
Technical Performance Ability to Install Dewatering Odor Control Ability to Meet Permit Limits Adaptability to Varying Influent	Long-Term Resiliency Ease of Capacity Expansion Level of Risk from Process Failures Ease of Incorporating Process Changes
O&M Process Control Adjustments Level of Complexity Maintenance Intensity	Implementation Constructability Permitting Construction Schedule Savings

3.3 Outcome

Following WSC’s presentation of the economic and non-economic comparisons between the two alternatives at the April 20, 2023 Board Meeting, the Board directed District staff to move forward with a packaged MBR. The preliminary design details and criteria captured in this Report are representative of a Packaged MBR.

4.0 Design Criteria

This chapter captures the key design criteria for design of the WRRF Upgrades that will govern sizing of facilities, equipment redundancy, operational approach and method, and treatment capacity.

IN THIS SECTION

- Effluent Requirements
- Wastewater Characterization
- Design Flows and Loads
- Design Standards

During preliminary design, influent flow and loading characteristics, redundancy and reliability criteria, and effluent water quality requirements are the main design criteria applied. Application of these criteria will allow for determination of treatment technology selection, process sizing, facility hydraulics, and site layout. As the design progresses, design standards are applied to specify equipment types, material selection, and design features for compliance with codes and regulations. A summary of these design criteria is captured in this section, except for reliability and redundancy criteria, which are captured in Section 5.3 with each process unit description.

4.1 Effluent Requirements

As previously introduced, new effluent limitations for copper, unionized ammonia, and nitrate were established in WDR Order No. R3-2017-0026 and carried through to TSO No. R3-2022-0046, requiring full compliance by September 30, 2027. The final effluent limitations of WDR Order No. R3-2017-0026 are captured in Table 13 by constituent and compliance period.

The most notable discharge requirements that drive the intensity of treatment requirements are the daily maximum nitrate limit of 10 mg/L as N, and the 30-day average un-ionized ammonia limit of 0.025 mg/L. These limits require a nitrification-denitrification process capable of consistently meeting the nitrogen limits. BOD removal will be well below the discharge requirements since BOD is removed faster than inorganic nitrogen constituents at the retention times required for nitrification-denitrification. TSS limits are also easily attainable with either clarification or direct filtration methods. Lastly, the total recoverable copper limit requires a measurable reduction through the treatment process. Copper and other heavy metal reduction can reach up to 98% in biological processes with adequate bioreactor solids concentrations and solids retention times (SRT) (3). The District monitored influent total recoverable copper levels through the TSO monitoring requirements over 14 sampling periods from June 2018 through September 2021 and the levels ranged from 50 to 151 µg/L with an average of 91 µg/L. At these influent concentrations, incidental copper removal through the biological process is expected to meet the effluent discharge limits without any specific treatment measures for copper.

Table 13 WDR Order No. R3-2017-0026 Discharge Requirements

Constituent	30-Day Average	7-Day Average	Daily Maximum
Biochemical Oxygen Demand (BOD) (mg/L)	30	45	90
Total Suspended Solids (TSS) (mg/L)¹	30	45	90
BOD and TSS Removal	85%	-	-
pH¹	6.0 - 8.3		
Nitrate (as N) (mg/L)	-	-	10
Oil and Grease (mg/L)	10	-	20
Chlorine, Total Residual (µg/L)	-	-	ND ²
Settleable Solids (mL/L)	-	-	0.1
Unionized Ammonia (mg/L)	0.025	-	-
Copper, Total Recoverable (µg/L)	11	-	22
Fecal Coliform Bacteria (MPN/100 mL)	200/400	-	-
Total Coliform Bacteria (MPN/100 mL)		23 ³	2,400
<p>^[1] Applied as an instantaneous effluent limitation.</p> <p>^[2] Non-detected by amperometric titration or an equally sensitive method.</p> <p>^[3] This is a seven sample median.</p>			

4.2 Wastewater Characterization

Performing a wastewater characterization of the raw influent at the District's WWTP provides quantification of historical flows and pollutant loads. Wastewater characterization helps with understanding of variances in influent characteristics over different averaging periods, as summarized below.

- Average Annual (AA): Represents the average flows and loads occurring during a 24-hours period based on historical measurements.
- Average Dry Weather Flow (ADWF): The average daily flow occurring during the months of June, July, and August, the three driest consecutive months on average from 2009 - 2022. During ADWF, infiltration and inflow (I/I) to the collection system is minimal and flows and loads are primarily a results of wastewater generation.
- Average Wet Weather Flow (AWWF): The average daily flow occurring during the months of December, January, and February, the three wettest consecutive months on average from 2009 - 2022. During precipitation events in AWWF months, I/I to the collection system contribute to maximum flow conditions.
- Max Month (MM): Consecutive 30-day period during which flows and loads are greatest. MM flows and loads may occur in wet weather months in years with high precipitation, or during dry weather months in years where tourism and residency rates are higher.
- Max Week (MW): Consecutive 7-day period during which flows and loads are greatest. Depending on the year, MW flows and loads may occur during significant precipitation events, or during dry weather months when tourism and seasonal residents increase wastewater generation.
- Max Day (MD): Day of the year during which flows and loads are the greatest. MD flows typically occur during precipitation events, while MD loadings vary between wet weather and dry weather months.
- Peak Hour (PH): Maximum flow occurring during any 1-hour period of any day of the year. PH typically occurs during the most significant wet weather event of the year. Loadings are not quantified for a PH averaging period since they do not govern any aspect of the design.
- Minimum Day: Day of the year during which flows and loads are lowest.
- Minimum Flow: Minimum diurnal flow occurring during the year.

The averaging periods summarized above are applied to the design for different purposes, as summarized in Table 14.

Table 14 Purpose of Averaging Periods for Design Application

Averaging Period	Purpose for Facility Design
Average Annual	Basis of sizing for pumping facilities, pipelines, and treatment processes
	Quantification of operation and maintenance requirements
	Quantification of flow and load peaking factors
Maximum Month	Sizing of chemical storage facilities
	Sizing of sludge handling facilities
	Sizing of biological treatment process
Maximum Week	Evaluating biological system tolerance to sustained peak loadings
Maximum Day	Sizing of disinfection process
	Determination of flow management strategy and hydraulics
Peak Hour	Sizing of equalization basin and preliminary treatment facilities
	Sizing of influent flow structures
	Determination of flow management strategy and hydraulics
Minimum Day	Determining lower threshold for nutrient loading to biological system
Minimum Flow	Sizing of pumps for conveyance and chemical feed systems
	Determine low range of flow measurement devices

Historical data provides a basis for projecting future flows and loads using metrics for anticipated service area growth. The projected flows and loads across different averaging periods are directly applied to facility sizing and hydraulic design for the WRRF Upgrades. This section summarizes the approach, analysis and results of the wastewater characterization performed for the District's WRRF Upgrades. Appendix D includes the Wastewater Characterization TM which reflects the analysis performed during preliminary design for the 2017-2021 period. As the design progressed through the end of calendar year 2022 and through the wet weather months of 2023, the wastewater characterization analysis was updated with 2017-2022 flow and load data as well as 2023 wet weather data to include the most recent and relevant data to improve accuracy of the historical data set. The Final Design Report will

include a Final Wastewater Characterization TM that includes the final flows and loads analysis for the Project.

4.2.1 Approach

Wastewater characterization includes analysis of both influent flows and pollutant loads. The flows are analyzed first, as pollutant loads are calculated directly from flows. WSC requested all available data from the District for the prior 10-years and assessed its relevance to the wastewater characterization effort. Upon review, it was determined that the District did not have any raw influent flow metering data. Available flow data for the existing WWTP was limited to effluent data from the effluent pump station downstream of Pond 2. Due to the high retention time of Pond 1 and Pond 2 and evaporation rates from their large surface areas, the effluent flow rate is expected to be significantly less than the influent flow rate and could not be accurately adjusted to represent influent flows.

Instead of using direct influent flow measurements, a combination of terminal lift station flow data from the collection system, flow meter testing at those lift stations, and Pacific, Gas & Electric (PG&E) power consumption data was applied to an alternative method for flow analysis:

1. Flow meters were placed on the discharge piping of each terminal lift station for a set period to obtain data for actual pumping rates, as compared to nameplate readings from each pump.
2. Power consumption was quantified using the pump curves for the pumps at each terminal lift station at the actual pumping rates from Step 1.
3. Historical PG&E power consumption data for each terminal lift station was obtained to allow for quantification of daily kilowatt-hour (kWhr) power at each lift station which was used to back calculate hours of pump runtime.
4. Runtime hours from Step 3 and actual pumping rates from Step 1 were used to estimate gallons pumped per day, which was then totaled for all three terminal lift stations to obtain estimated historical daily influent flow to the WWTP.

This method provides a reasonable estimation of influent flows, which is warranted due to the lack of available data. Furthermore, this method does not allow for a standard approach of statistically analyzing influent flows to determine their distribution and quantify influent flows based on probability of exceedance at different averaging periods; therefore, direct calculation of influent flows over different averaging periods was performed. For example, Max Month flows were quantified using the maximum of a 30-day running average over the data set, instead of selecting a flow at a probability of exceedance value equal to 91.7% (11 months/12 months).

Analysis of historical loadings included review and analysis of historical BOD, TSS, and total Kjeldahl nitrogen (TKN) influent data. The District also performed sampling events to quantify additional influent constituents to support the design efforts and improve accuracy of the wastewater characterization. The constituents analyzed from the additional influent sampling events included:

- Biochemical Oxygen Demand (BOD)
- Soluble BOD (sBOD)
- Carbonaceous BOD (cBOD)
- Chemical Oxygen Demand (COD)
- Soluble COD (sCOD)
- Total Suspended Solids (TSS)
- Volatile Suspended Solids (VSS)
- Alkalinity
- Total Ammonia Nitrogen (ammonia)
- Total Kjeldahl Nitrogen (TKN)
- Metals

The compiled set of water quality data was used to develop historical loadings for BOD, TSS, TKN and Ammonia. Loadings are calculated by multiplying the constituent concentration by the influent flow (in MGD) and a factor of 8.345, to obtain loadings in pounds per day (ppd). Because the loading data is directly calculated from the influent flow data, the same direct calculation method was performed to quantify loadings over different averaging periods.

Additional details of the wastewater characterization approach and analysis are captured in the Wastewater Characterization TM located in Appendix D.

4.2.2 Historical Flows and Loads

Using the approach outlined above and as described in the Wastewater Characterization TM, historical flows and loads were estimated over the prior 6-year period from 2017-2022. The 6-year timeline represented more conservative (i.e., greater) values and was more representative of recent trends in residency rates, drought conditions, and increased rate of residents working from home, which all directly impact influent wastewater characteristics. However, due to significant rainfall between January and March in 2023, the flow analysis accounted for that time period in selecting historical MM, MW, MD, and PH flows. Table 15 summarizes the historical flows and loads for each averaging period.

Table 15 Historical Flows and Loads from 2017-March 2023

Parameter		2017	2018	2019	2020	2021	2022	Jan-Mar 2023	Selected (6-yr Avg. or Max)
AA	Flow (MGD)	0.21	0.19	0.21	0.20	0.19	0.20		0.20
	BOD Loading (ppd)	610	650	560	680	730	640		650
	TSS Loading (ppd)	650	660	650	690	640	630		660
	TKN Loading (ppd-N)	110	90	90	100	130	130		110
ADWF	Flow (MGD)	0.20	0.20	0.20	0.21	0.19	0.20		0.20
AWWF	Flow (MGD)	0.25	0.18	0.23	0.18	0.20	0.19		0.21
MM	Flow (MGD)	0.30	0.21	0.30	0.24	0.22	0.23	0.39	0.39 ¹
	BOD Loading (ppd)	680	760	700	880	980	810		980
	TSS Loading (ppd)	770	800	850	890	820	880		900
MW	Flow (MGD)	0.39	0.28	0.34	0.27	0.32	0.29	0.46	0.46 ¹
	BOD Loading (ppd)	830	820	850	1,060	1,090	790		1,100
	TSS Loading (ppd)	860	850	870	1,080	910	880		1,100
MD	Flow (MGD)	0.52	0.46	0.45	0.32	0.64	0.54	0.74	0.74 ¹
	BOD Loading (ppd)	1,080	990	880	1,300	1,340	1,040		1,340
	TSS Loading (ppd)	1,250	1,150	1,130	1,350	930	1,240		1,350
PH	Flow (MGD)	1.08	0.67	0.96	1.14	1.12	1.21	1.35	1.35 ¹
Min Day	Flow (MGD)	0.15	0.16	0.15	0.15	0.14	0.12		0.12
^[1] Selection based on flows from January 2023 through March 2023.									

Peaking factors for historical flows, in relation to AA flow, were developed to provide a basis for projecting future flows, as summarized in Table 16.

Table 16 Historical Flow Peaking Factors

Averaging Period	Historical Flow (MGD)	Peaking Factor (to AA)
AA	0.20	1.0
ADWF	0.20	1.0
AWWF	0.21	1.0
MM	0.39	1.9
MW	0.46	2.3
MD	0.74	3.7
PH	1.35	6.7

Similarly, peaking factors for historical loads were calculated, as summarized in Table 17.

Table 17 Historical Loadings and Peaking Factors

Constituent	Averaging Period	Historical Loading (ppd or ppd as N)	Peaking Factor (to AA)
BOD	AA	650	1.0
	MM	980	1.5
	MW	1,100	1.7
	MD	1,340	2.1
TSS	AA	660	1.0
	MM	900	1.4
	MW	1,090	1.7
	MD	1,350	2.0
TKN	AA	110	1.0
	MM	-	1.5
	MW	-	1.7
	MD	-	2.1
Ammonia	AA	80	1.0
	MM	-	1.5
	MW	-	1.7
	MD	-	2.1

4.2.3 Projected Flows and Loads

Historical flows and loads were used to project future flows and loads through a 20% increase of the number of housing units. The District's historical and future service area is almost exclusively domestic; therefore, the increase in housing units was proportionally applied to historical flows and loads to calculate the projections. The exception to this projection methodology is the PH flow, which was selected based on the PH flow calculated from the equalization volume analysis captured in Section 5.2.1.2. Details of the projection method approach and analysis can be referenced in Appendix D. Table 18 includes a summary of the projected flows and loads for each averaging period.

Table 18 Projected Flows and Loads

Parameter	Units	AA	MM	MW	MD	ADWF	AWWF	PH	Min Day
Flow	MGD	0.24	0.46	0.55	0.88	0.24	0.25	1.39	0.15
BOD	mg/L	390	305	290	223	-	-	-	
	ppd	780	1,170	1,330	1,640	-	-	-	
TSS	mg/L	395	289	294	215	-	-	-	
	ppd	790	1,110	1,350	1,580	-	-	-	
TKN	mg/L-N	70	52	50	38	-	-	-	
	ppd-N	140	200	230	280	-	-	-	
Ammonia	mg/L-N	50	39	35	27	-	-	-	
	ppd-N	100	150	160	200	-	-	-	

4.3 Design Flows and Loads

The selected design flows and loads that the WRRF treatment processes will be designed against are summarized in Table 19. These flows and loads align with the projected flows and loads for AA, MM, MW, ADWF, and AWWF conditions. MW conditions represent the flow and load design condition for the treatment processes downstream of the Headworks. Flow parameters above the MW design condition apply specifically to the hydraulic design of the Headworks, Influent Splitter Box, and Equalization Basin. The hydraulic requirements and design approach for the Influent Splitter Box and Equalization Basin are discussed in Section 5.3, and the design flow selection in relation to Equalization Basin volume requirements is covered in Section 5.2.1.

Table 19 Design Flows and Loads

Parameter	Units	AA	MM	MW	MD	ADWF	AWWF	PH	Min Day
Flow	MGD	0.24	0.46	0.55	0.88	0.24	0.25	1.39	0.15
BOD	mg/L	390	305	290	223	-	-	-	
	ppd	780	1,170	1,330	1,640	-	-	-	
TSS	mg/L	395	289	294	215	-	-	-	
	ppd	790	1,110	1,350	1,580	-	-	-	
TKN	mg/L-N	70	52	50	38	-	-	-	
	ppd-N	140	200	230	280	-	-	-	
Ammonia	mg/L-N	50	39	35	27	-	-	-	
	ppd-N	100	150	160	200	-	-	-	

4.4 Design Standards

Several design standards will be applied to the WRRF Upgrade design, including industry, local, state, and federal standards, codes, and regulations. The WRRF Upgrade design will comply with the relevant requirements and latest versions of the following standards and organizations as applicable:

- American Concrete Institute (ACI)
- American National Standards Institute (ANSI)
- American Society of Mechanical Engineers (ASME)
- American Water Works Association (AWWA)
- American Society of Heating, Refrigeration and Air Condition Engineers (ASHRAE)
- Association for Materials Protection and Performance (AAMP, formerly NACE-SSPC)
- ASTM International (ASTM)
- California Title 22 Regulations
- California Building Code (CBC)
- California Division of Occupational Safety and Health (Cal/OSHA) and The Occupational Safety and Health Administration (OSHA)
- California Energy Code
- California Fire Code (CFC)
- California Green Building Code (CALGreen)
- California Mechanical Code (CMC)
- California Plumbing Code (CPC)
- County of San Luis Obispo Civil and Transportation Standards
- Engineers Joint Contract Documents Committee (EJCDC) Procurement Contracts
- Hydraulic Institute (HI)
- National Electric Code (NEC)
- National Electrical Manufacturers Association (NEMA)
- National Electrical Testing Association (NETA)
- National Fire Protection Agency (NFPA) 70E – Standard for Electrical Safety in the Workplace
- National Fire Protection Agency (NFPA) 820 – Standard for Fire Protection in Wastewater Treatment and Collection Facilities
- Underwriters Laboratory (UL)
- United States Department of Agriculture (USDA) Water & Waste Disposal Loan & Grant Program

5.0 Planned WRRF Upgrades

This chapter provides details of the planned WRRF Upgrades for existing facilities, and new process units, supporting facilities, and buildings. Geotechnical conditions studied as part of the geotechnical site investigation are also captured in this chapter.

IN THIS SECTION

- Overview
- Facility Hydraulics
- Process Units
- Existing Facilities
- EI&C Facilities
- Building Programming
- Geotechnical Conditions

5.1 Overview

The planned WRRF upgrades include decommissioning and repurposing of the existing on-site treatment ponds and construction of a new MBR treatment plant to produce disinfected tertiary water. Pond 1 will be taken offline, cleaned, and its liner removed, then be repurposed as a storage yard area with an earthen driveway for vehicle access. Pond 2 will be taken offline, cleaned, have its liner replaced, then be repurposed as the Equalization Basin. The existing effluent pump station and chlorination facilities will be decommissioned, demolished, and replaced with new facilities. Modifications and plans for off-site facilities at the Effluent Disposal Site are captured in Section 0.

Starting at the beginning of the process flow, the WRRF Upgrades include rerouting of the influent wastewater flows from terminal lift stations 2, 3, and 10. Raw influent wastewater that is currently conveyed to Pond 1 through influent force mains will be re-routed through buried piping to the Headworks located near the northern corner of the existing Pond 2. Wastewater will flow by gravity through the Headworks facility which consists of a single mechanical Coarse Screen or a manual bypass to a Manual Bar Rack Screen if the Coarse Screen needs to be taken offline.

Influent flows greater than the MW flow of 0.55 MGD will be routed by gravity downstream of the Headworks at the Influent Splitter Box to the Equalization Basin through an adjustable slide gate and flows less than 0.55 MGD will be conveyed by gravity to the fine screens at the MBR. The Equalization Basin will consist of a single basin that is graded and segmented to allow for storage of diurnal flows in a depressed area of the basin, as well as peak wet weather flows. Equalized diurnal or peak wet weather flows will be pumped out of the basin through the Equalization Basin Pump Station to the fine screens at the MBR based on flow controls from influent flow meter readings at the Headworks for peak flows or by operator discretion for diurnal flows.

The Packaged MBR process design includes two (2) parallel Fine Screens followed by an activated sludge process that flow into parallel Membrane Tanks. The hydraulics of the MBR process will be determined following selection of the Packaged MBR seller and submittal approval of their design documents. A provision for diverting RAS to the Equalization Basin will be required of the Packaged MBR seller to accommodate routine startup and maintenance activities.

WAS from the MBR process will be conveyed from the Packaged MBR process to the Dewatering Facility for dewatering via a Screw Press. Sludge feed pumps will pull suction from the Packaged MBR process and pump to a single Screw Press. Dewatered solids will be stored in a roll-off bin and filtrate from the Screw Press will be returned to the Equalization Basin through an In-Plant Return Pump Station.

Permeate from the MBR process will be pumped to the Effluent and Utility Water (UW) Pump Station where it is dosed with sodium hypochlorite upstream of the pump station wet well. The UW pumps will supply treated effluent for UW uses throughout the WRRF and the remaining

flow will be conveyed through the effluent pipeline to the Effluent Disposal Site. The UW pumps will be sized to accommodate potential future recycled water irrigation demands at the nearby Gateway Park. Additionally, the Effluent and UW Pump Station will be designed to accommodate the addition of dedicated recycled water pumps to supply other potential recycled water uses in the future. A Chemical Storage Area will include storage, containment, and conveyance for chemicals required for the MBR process and chlorination as well as space for potential future chemical storage totes. Details of the upgrades specific to the process units (e.g., Headworks, MBR, etc.) are included in Section 5.3.

Motor control centers (MCCs) for the process equipment will be located in a prefabricated Electrical Building and a diesel-powered Standby Generator will provide emergency backup power. Details of the electrical, instrumentation, and control (EI&C) upgrades are included in Section 5.5.

The existing Laboratory currently used for water quality analysis and process sample storage will remain in place for continued use. The existing Maintenance Building will be retrofitted to provide SCADA interfaces, operator workstations, a breakroom, and restrooms. Details of the building programming are included in Section 5.6.

Site improvements will include minor grading, roadway improvements for the access road from Heritage Road, construction of an access-egress loop around the WRRF, and stormwater improvements that allow sheet flow across the site and stormwater inlets along the paved areas to convey stormwater to existing drainage locations at the site. Approximately 3,200 feet of the effluent discharge line will be replaced with 8" C900 pipe to accommodate the increased system pressures associated with the design flow conditions.

A process flow diagram of the treatment process is included in Figure 17.

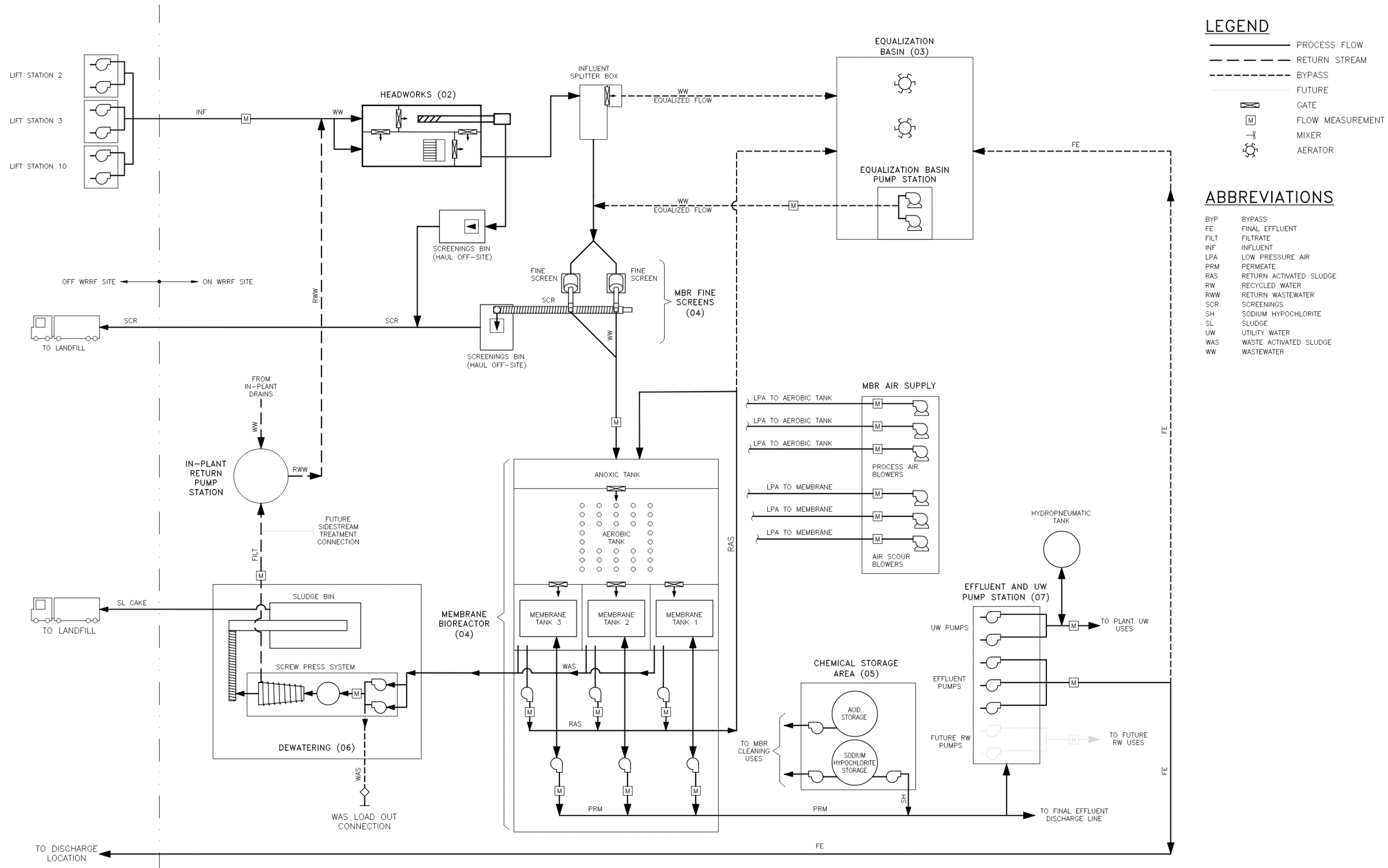

Figure 17 HRCSD WRRF Upgrade Process Flow Diagram

5.2 Facility Hydraulics

The hydraulics of the existing site are controlled by the force main pressure from the collection system's terminal lift stations, the Pond 1 and Pond 2 elevations, and the effluent pump station. The influent force mains have sufficient head to pump approximately 8 to 10 feet above the top of existing pond elevations, which are approximately 915.5-ft elevation¹. Pond 1 flows into Pond 2 by gravity and flow from Pond 2 into the existing effluent pump station is also by gravity. Pond 1 will be repurposed as a non-process facility, Pond 2 will be repurposed as the Equalization Basin, and the existing effluent pump station will be replaced.

As introduced in the conceptual site plan in Chapter 2.0, siting of the WRRF Upgrades is southwest of Pond 2 at a lower level of the site ranging from approximately 896-ft to 900-ft elevation. , Because the Packaged MBR is installed on top of an on-grade slab, the hydraulic grade line of the Packaged MBR fine screens is estimated to be 913-ft elevation, which will govern upstream hydraulics at the Headworks and Influent Splitter Box, and require the equalized flow from the Equalization Basin to be pumped to the Packaged MBR fine screens.

To utilize the pumping energy from the collection system, the Headworks will be constructed as an above grade packaged unit to allow for downstream gravity flow to the Packaged MBR. The Influent Splitter Box will be located at the northern corner of Pond 2 as a partially buried structure to allow for gravity flow into the Equalization Basin and the Packaged MBR. A preliminary hydraulic profile of the liquid stream process is included in Figure 18.

¹ Based on Site Topographic Plan and North American Vertical Datum of 1988 (NAVD 88), MBS Land Surveys, 2022.

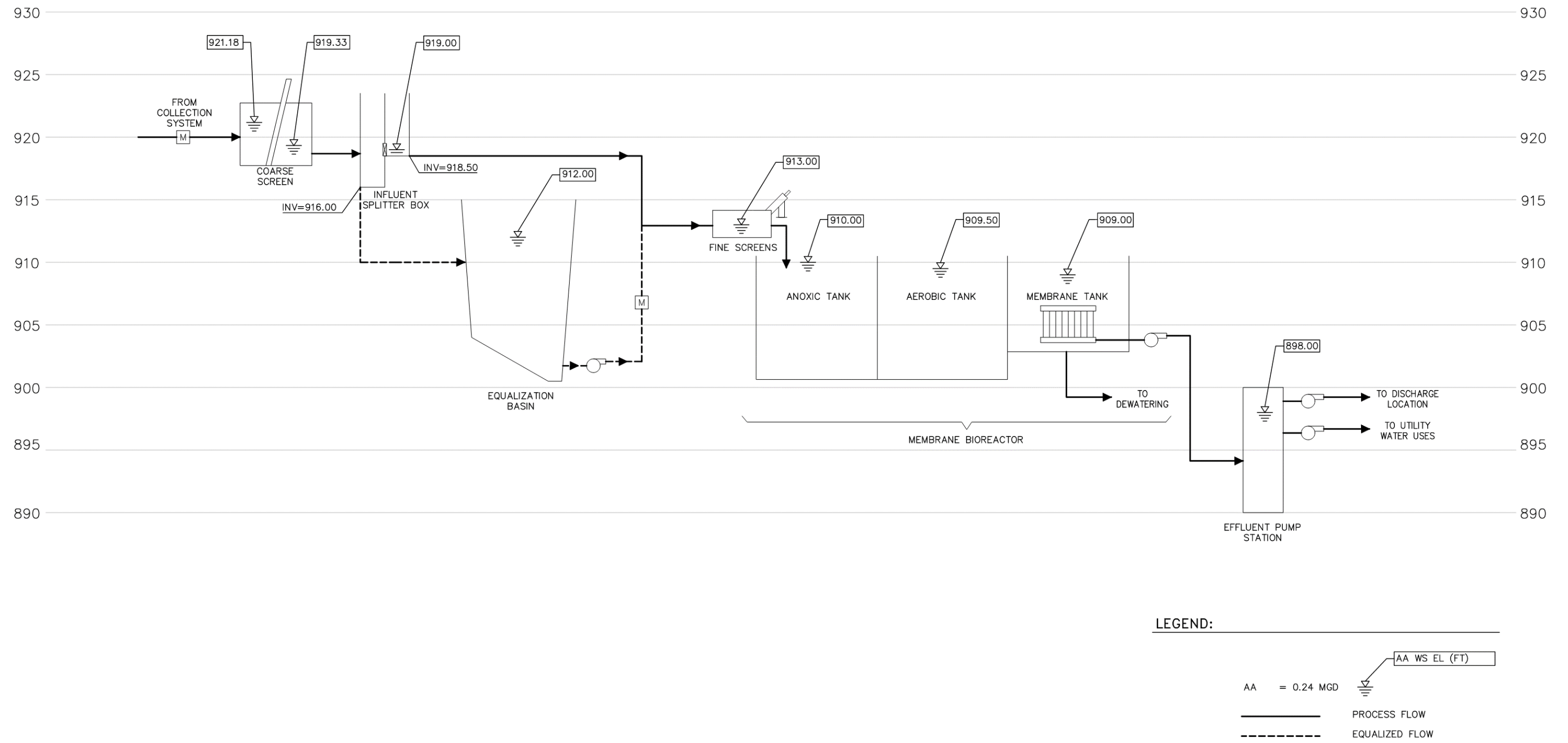

Figure 18 Preliminary Hydraulic Profile

5.2.1 Flow Equalization

Flow equalization analysis for the WRRF Upgrades leveraged the influent flow data set that was described in Section 4.2. Analysis included review of hourly diurnal flow data from a dry weather month and hourly flow data from the historical max week flow period which captured a significant precipitation event:

- Diurnal Analysis
 - July 21, 2021
- Peak Wet Weather Analysis
 - January 27, 2021 through February 2, 2021 (5.9-inches of precipitation)

The diurnal equalization volume will govern how the Equalization Basin is graded and designed to accommodate storage of lesser but more consistent storage volumes that minimize operational and maintenance attention for conveyance and washdown requirements. The peak wet weather equalization governs the storage capacity requirements for the Equalization Basin. The following subsections describe the approach and results of each flow equalization analysis.

5.2.1.1 Diurnal Equalization Analysis

A representative hourly diurnal flow curve was developed from the July 21, 2021 flow data to project a typical diurnal flow pattern at the buildout AA and ADWF flow of 0.24 MGD. The required diurnal equalization volume was calculated using an inflow cumulative volume diagram where the cumulative inflow volume is plotted versus the time of day along with a straight line flowrate. The required volume is then calculated using the maximum difference between the two plotted lines. The cumulative volume diagram for this analysis is shown in Figure 20, which indicates a required diurnal equalization volume of 30,000 gallons.

Figure 19 Dry Weather Diurnal Flow Patterns

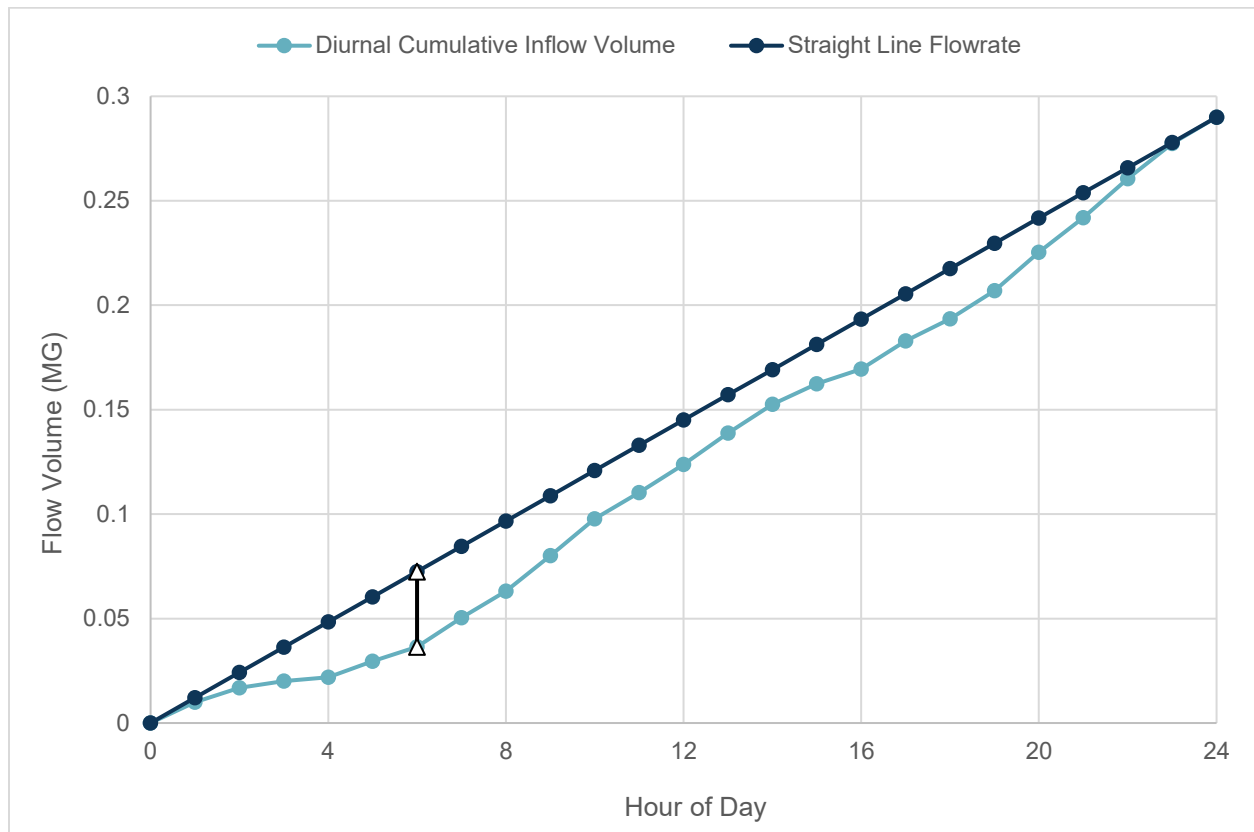

Figure 20 Diurnal Inflow Cumulative Diagram

5.2.1.2 Wet Weather Equalization Analysis

A standard approach to analyzing wet weather flow data for equalization calculations may include collection system flow monitoring and collection system modeling. Collection system modeling can help quantify wet weather peaking factors, I/I, and future contributions to wet weather flows based on age-based pipeline modeling and baseline wastewater generation increases from service area growth. This information was not available for this analysis; therefore, historical flow and precipitation data was reviewed to identify the most intense rain event based on a 7-day running average of daily precipitation totals. The future MW flow

condition is likely to occur during a wet weather event based on the wastewater generation patterns in the Heritage Ranch community (i.e., increased residency rate and tourism would not have such a pronounced impact on wastewater flows), and review of historical peak flow event data which occurs consistently during or following precipitation events in wet weather months.

The January 27, 2021 through February 2, 2021 period was selected to develop a 7-day influent hydrograph for the influent flow to the WWTP. Other 7-day periods were analyzed to quantify equalization requirements, but the hydrograph from this period yielded the greatest wet weather equalization volume requirement. To simulate a future MW flow scenario, the 7-day influent hydrograph was scaled up to match a MW flow of 0.55 MGD, the projected MW flow condition. Design flow averaging periods from MD to MW were evaluated to quantify respective equalization volume requirements:

- Max Day: Flows greater than 0.88 MGD are diverted to the Equalization Basin
- Max 2-Days: Flows greater than 0.74 MGD are diverted to the Equalization Basin
- Max 3-Days: Flows greater than 0.65 MGD are diverted to the Equalization Basin
- Max Week: Flows greater than 0.55 MGD are diverted to the Equalization Basin

The equalized influent flows for the four averaging periods are included in Figure 21, along with notation of the required Equalization Basin volumes as parenthetical references in the legend. The equalization volumes noted are direct calculations from the hydrograph and do not include a safety factor. The flat period of each averaging period curve indicates the period that the Equalization Basin is in use either filling or draining. As the design flow condition decreases, this period increases in duration.

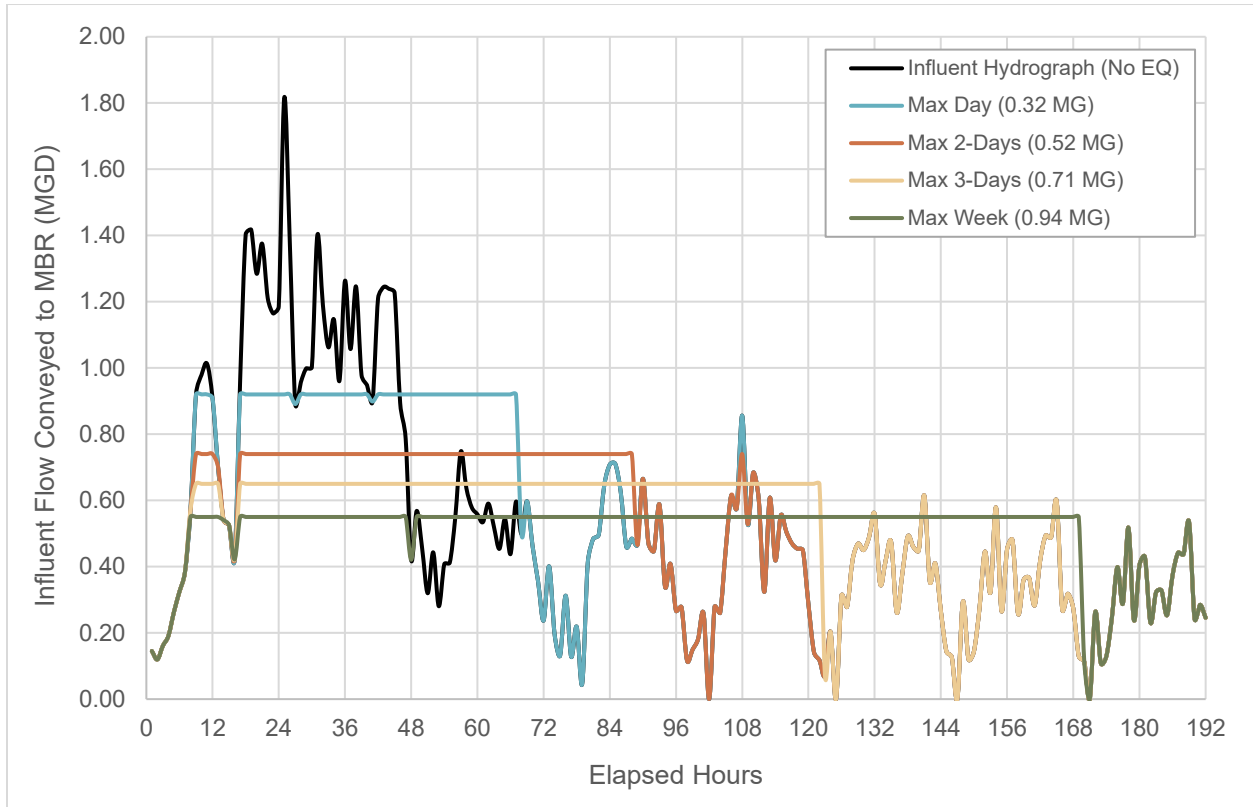

Figure 21 Wet Weather Flow Equalization for Different Design Flow Scenarios

Selection of equalization volume and design flow is a balance between cost of equalization basin construction, operational and maintenance intensity of operating the equalization facilities, and potential savings of downsizing and impacts to downstream processes. Pond 2, the pond that will be repurposed as the Equalization Basin, has a current operational capacity of 1.7 MG with 2-feet of freeboard. Improvements to the Equalization Basin include cleaning, minor grading, and replacing the liner, all of which will have similar effort regardless of the volume generated by the averaging period condition selected for design since the basin is already constructed. As the design flow increases (e.g., MW to MD), additional freeboard would be available in the basin and a greater safety factor for storage would be realized because of the high available storage volume of Pond 2.

As presented in Section 4.3, the MW flow of 0.55 MGD was selected as the design flow to the treatment process, which yields an Equalization Basin volume requirement of 0.94 MG. With inclusion of a 20% storage safety factor the minimum required equalization volume is 1.1 MG. With minor grading of the existing bottom surface and a minimum operational freeboard of 3-feet, the Equalization Basin will have a greater storage volume. Selection of this design flow allows for downsizing of the treatment facilities to potentially save on capital and operating costs for the WRRF Upgrades.

5.3 Process Units

This section provides a summary of the function and purpose of the main treatment process units, their integration with other process units, reliability and redundancy criteria, and sizing based on design flows and loads.

5.3.1 Headworks

The Headworks facility consists of a Coarse Screen to remove inorganic solids and debris from the wastewater stream prior to biological treatment. Coarse Screens are reliable, spare and wear parts are low cost and require little storage space, and replacement of wear parts is not maintenance or equipment intensive.

The Headworks facility is critical to removing solids that can damage downstream equipment and cause floatable or settled solids buildup throughout the process. Wastewater will be conveyed from the influent force mains into a single force main that will flow into an above grade tank mounted Coarse Screen unit. Gates internal to the tank will allow manual bypass into a channel with a manual bar rack screen in the event the Coarse Screen needs to be taken offline. The Coarse Screen will be designed to convey and screen the PH flow.

The Coarse Screen will be a tank mounted above grade system with direct flange connections to upstream and downstream piping. The above grade construction will allow gravity flow from the Coarse Screen to the MBR. The Coarse Screen will be a perforated plate style with an inclined screw that conveys screenings to an integrated washer compactor. All screenings from the Coarse Screen will be directly conveyed from the integrated compactor unit into a roll-away bin for periodic off hauling to a landfill.

The Coarse Screen design criteria is summarized in Table 20.

Table 20 Coarse Screen Design Criteria

Criteria	Design/Value
Type	Bar
Opening	0.25-inch
Redundancy	
Mechanical Screen	1
Manual Screen	1
Washer-Compactor	Integrated into Coarse Screen
Design Flow	1.4 MGD

5.3.2 Influent Splitter Box

The Influent Splitter Box will be constructed downstream of the Headworks Facility at the northern corner of the existing Pond 2 as a partially buried structure. The Influent Splitter Box will be configured to convey flows in excess of MW flows to the MBR or divert flows in excess of MW flows to the Equalization Basin. Level in the Influent Splitter Box will be controlled by a submerged orifice plate which will convey wastewater up to MW flows until the level in the Influent Splitter Box will then rise and overflow over a weir slide gate into a separate chamber that conveys wastewater the Equalization Basin. Inverts on both outlets of the structure will be located at the bottom of the structure to allow solids to flush out of the Influent Splitter Box to downstream processes for capture and treatment.

5.3.3 Equalization Basin

The Equalization Basin's primary purposes are to attenuate peak flows to the treatment process and provide diurnal flow and load equalization to provide more stable treatment. It will consist of a single basin with two (2) level controlled surface aerators mounted on slide rails and cables that will rise and fall with the water surface. The aerators will help mitigate odors, keep any solids in suspension, and prevent raw influent from becoming septic. Based on a 0.02 hp/1,000 gallon volume (3), the total mixing energy requirement is 18 hp. Wharf heads supplied with UW will be located along the perimeter of the basin to provide operators wash down water for cleaning the basin as needed. The Equalization Basin will be sized for an operational volume of 0.89 MG. The Equalization Basin design criteria is summarized in Table 21. Details of the Equalization Basin design approach is captured in Section 5.2.1.

Table 21 Equalization Basin Design Criteria

Criteria	Design/Value
Redundancy	
Number of Zones	1
Surface Aerators	2
Operations	
Washdown	Wharf Heads
Mixing Requirement (Total)	18 hp
Storage Volume	1.1 MG at 4-ft of freeboard

The Equalization Basin will be graded and segmented to allow for storage of diurnal flows in a depressed area of the basin near the inlets and outlets, with the remaining area sloped toward the depressed area for easy washdown and drainage of peak wet weather flows. Equalized diurnal or peak wet weather flows will flow by gravity to an Equalization Basin Pump Station at the western corner of the Equalization Basin. Two (2) submersible pumps will provide hydraulic lift of the equalized wastewater to the downstream MBR fine screens. The pumps will be controlled based on influent flow to the plant as measured by the influent flow meter upstream of the Headworks. Once influent flows are below MW flows by a certain factor for a given amount of time, the Equalization Basin Pump Station will convey flows downstream and shut off if influent flows again exceed MW flows. Operators will also retain manual control of the pumps for wet weather and diurnal flow operations.

Table 22 Equalization Basin Pump Station Design Criteria

Criteria	Design/Value
Redundancy	
Number of Pumps	2 (N+1)
Design	
Pump Type	Submersible Centrifugal
TDH	20 feet
Motor Size	7.5 hp
Pumping Capacity	480 gpm

5.3.4 Packaged Membrane Bioreactor

The design of the MBR treatment process (including hydraulics) will be delegated to the Packaged MBR Seller as specified in the Equipment Pre-procurement contract. Specifications require the Seller to design an activated sludge system capable of providing nitrification-denitrification (i.e., total nitrogen removal) with membranes that provide direct solids-liquid phase separation of the mixed liquor suspended solids (MLSS). To protect the membranes, redundant fine screens will also be required upstream of the MBR. Redundancy requirements include an N+1 configuration that will allow the Packaged MBR system to treat the 0.55 MW design flows and loads with one (1) Membrane Tank out of service.

The key process design criteria for the MBR are based on the effluent requirements for un-ionized ammonia and nitrate. Un-ionized ammonia is typically lower in effluent wastewater since the pH of effluents are low enough that most ammoniacal nitrogen is in the form of ionized

ammonia (i.e., ammonium). As temperature and pH increase, the percentage of ammoniacal nitrogen that is un-ionized also increases. At the pH and temperature expected for the WRRF effluent, the un-ionized ammonia limit requires full nitrification of the wastewater to meet the limit reliably and consistently, while accounting for potential fluctuations in both pH and temperature parameters. Furthermore, the daily maximum nitrate limit of 10 mg/L-N requires consistent denitrification but does not require any enhanced nitrogen removal process typical of some facilities with lower total nitrogen or nitrate limits.

The MBR Seller is responsible for determining availability of influent carbon for denitrification and alkalinity for effective nitrification, both of which are typically the limiting factors for nitrification-denitrification processes. External carbon sources such as glycerol or MicroC can be introduced upstream of anoxic basins to maintain the denitrification reactions and drive nitrates lower, while alkaline sources such as sodium hydroxide can be introduced in the aeration basins to maintain a pH range that does not inhibit nitrification. The process design parameters that will be provided to the MBR Sellers during equipment pre-procurement advertisement are included in Table 23, along with a summary of the other design criteria.

Table 23 Packaged MBR Design Criteria

Criteria	Design/Value
Raw Influent Constituent Ratios	
COD:BOD ₅	1.8
sCOD:COD	0.30
sBOD ₅ :BOD ₅	0.55
TKN:BOD	0.17
Redundancy	
Membrane Tanks & Blowers	N + 1 Configuration
Permeate Pumps	N + 1 Configuration
RAS Pumps	N + 1 Configuration
Process Blowers	N + 1 Configuration
Monitoring	
Dissolved Oxygen + pH	Each Biological Tank
Ammonia	U/S & at end of Aeration Tank
Nitrate	U/S of Membrane Tank
TSS	U/S of Membrane Tank
Operation	
Full Nitrification-Denitrification	Yes
Phosphorus Removal	No
Aeration Method	Fine Bubble Diffusion
Process Parameters	
Temperature	15 – 25 °C

5.3.5 Dewatering Facility

Solids handling at the WRRF will include dewatering of undigested solids from the MBR process. A dewatering technology alternatives analysis was performed as part of the PDR effort to identify the preferred dewatering technology. A screw press dewatering unit was recommended to the District and selected over a belt filter press and centrifuge due to its low footprint, ease of operation, minimal moving parts to maintain, and lower energy consumption relative to a centrifuge. Screw presses can reliably dewater low solids content WAS to greater than 15% solids with little operator supervision or adjustments. They also come complete as skid systems with integrated controls, polymer dosing, and pumping in a small footprint with easy equipment access. Solids thickening is not required upstream of screw press dewatering due to the high MLSS from MBR processes that can be dewatered to 18% solids with polymer addition.

A screw press skid system and solids storage roll-off bin will be located outdoors on a slab with an overhead canopy structure. Skid mounted self-priming sludge feed pumps will pull WAS directly from the Membrane Tanks for dewatering. Stored dewatered solids will be off hauled regularly through a solids disposal contractor. The Dewatering Facility will include a driveway for ease of access to the solids storage roll-off bin. Filtrate from the Screw Press will be returned to the Equalization Basin through an In-Plant Return Pump Station.

The Dewatering Facility design criteria is summarized in Table 24.

Table 24 Dewatering Facility Design Criteria

Criteria	Design/Value
Type	
Dewatering Unit	Screw Press
Redundancy	
Dewatering Unit Number	1
Solids Feed Pumps	2
Operation	
Dewatering Frequency	5 days; 8 hours/day
Polymer Dosing	25-30 pounds per dry ton
Estimated Cake Solids	15-18%
Solids Capture	>95%

5.3.6 Effluent and Utility Water Pump Station

The Effluent and Utility Water Pump Station consists of a wet well and vertical turbine pumps to provide effluent conveyance to the effluent disposal location and UW supply to in-plant uses. Permeate from the MBR process will be pumped to the Effluent and UW Pump Station wet well, disinfected with sodium hypochlorite, and either used directly for in-plant uses as UW or disinfected again and discharged by the effluent pumps through the effluent pipeline. The UW pumps will be sized to accommodate future recycled water irrigation demands at the nearby Gateway Park. Additionally, the Effluent and UW Pump Station will be designed to accommodate the addition of more recycled water pumps to supply other recycled water uses in the future.

The effluent pumps will be sized to provide two (2) duty and one (1) standby pump to convey the maximum 0.55 MGD design flow with the ability to ramp up approximately 10% over that flow rate to accommodate any transient peaks in flow from the MBR permeate pumps. The key constraint for the effluent pump design is the pressure class rating of the effluent pipeline which starts out as PVC Class 200 piping (200 psi max rating) for the first 5,700-ft of length, then transitions to PVC Class 160 piping (160 psi max rating). Based on record drawings and District supplied information, that effluent pipeline was constructed in the late 1970s and has not been repaired or replaced since. To remain under the 200 psi and 160 psi ratings of the effluent pipeline, the flow from the effluent pumps would need to be limited to approximately 0.40 MGD and nearly 2 MG of equalization volume would be required upstream. Increasing equalization

volume requirements to that level and creating long-term operational, maintenance, and odor mitigation concerns associated with consistently equalizing flows was considered disadvantageous for a facility that is undergoing an upgrade. The District and WSC identified two alternatives to alleviate this constraint at the 0.55 MGD pumping rate:

Alternative 1: Locate an intermediate pump station near the halfway point of the effluent pipeline to reduce the total dynamic head requirements of the effluent pumps and thereby reduce the effluent pipeline pressures. The intermediate pump station would convey flows to the effluent disposal site. Location of the intermediate pump station is governed by the total dynamic head requirements at each pump station to remain under the existing pipeline pressure ratings.

Alternative 2: Replace a given length of the existing effluent pipeline starting from the effluent pump station with a higher-pressure class pipeline that can withstand the higher initial pressures in the system. The length of the pipeline that would be replaced is based on an evaluation of where system pressures would fall under the 200 psi pressure rating for the first reach of PVC Class 200 pipe at different pipe diameter alternatives.

WSC performed an analysis of these two alternatives using a 20-year life cycle cost analysis as the basis for evaluation. Although the capital cost associated with Alternative 1 was estimated to be lower than Alternative 2, the preferred alternative was determined to be Alternative 2 due to the high risk of discharging highly pressurized flows through the existing aged pipeline. A pressure analysis showed that approximately 3,200 feet of the existing 6-inch PVC Class 200 pipe needs to be replaced with 8-inch C900 (with 305 pressure rating) pipe to maintain optimal pressure conditions in the pipeline at the maximum flow of 0.55 MGD and a pipeline max pressure safety factor of 25% compared to the pipeline pressure rating.

Sizing of the UW pumps is performed by quantifying and characterizing in-plant uses as either intermittent or continuous demands. Two (2) UW pumps were sized to supply the in-plant UW demands as well as the future recycled water demands for irrigation of the nearby Gateway Park. A blind flange connection will be available for future construction of recycled water piping. A hydropneumatic tank downstream of the pumps will help stabilize pressure in the UW distribution system to mitigate high pump cycling of the UW pumps. A summary of the UW demands is included in Table 25.

Table 25 Utility Water System Demands

Utility Water Use	Type	Unit Demand (gpm)	Pressure (psi)	No. of Units	Operation	Design Demand (gpm)
Hose Bibbs for Maintenance	Intermittent	4.1	TBD	8	Two in use at any given time	8
MBR Foam Control Spray System	Intermittent	30	TBD	1	Continuous	30
Dewatering (Drum Shower Header)¹	Intermittent	47	30	1	15s On/15min Off	12
Dewatering (Headbox Shower Header)¹	Intermittent	16	30	1	10s On/10min Off	3
Dewatering (Pan Shower Header)¹	Intermittent	10	30	1	15s On/15min Off	2.5
Irrigation	Intermittent	5	75	2	As required	10
Headworks (Coarse Screen)	Intermittent	10	60	1	30s on/15min off	5
Headworks (Integrated Washer-Compactor)	Intermittent	138	60	1	30s on/15min off	19
Headworks (Fine Screens)	Intermittent	30	40	1	30s on/15min off	15
Equalization Basin (Wharf Hydrants)	Intermittent	100	80	3	One in use at any given time	100

¹ Only one Dewatering Utility Water Use will be demanded at a given time.

The Effluent and UW Pump Station design criteria is summarized in Table 26.

Table 26 Effluent and UW Pump Station Design Criteria

Criteria	Design/Value
Effluent Pumps	
Type	Vertical Turbine
Redundancy	2 Duty, 1 Standby
Pumping Capacity	0.55 MGD; 380 gpm Total; 190 gpm each
UW Pumps	
Type	Vertical Turbine
Redundancy	1 Duty, 1 Standby
Demands	
Demand Range	33 - 200 gpm
Design Pumping Capacity	
UW Pumps	100 gpm

5.3.7 Disinfection

The existing disinfection system includes a sodium hypochlorite storage tank, a peristaltic feed pump, and a dosing point located in a vault along the main entrance road to the WWTP facility, as shown in Figure 22. The WRRF Upgrades will include demolition of the existing storage tank and chemical feed pump but will maintain the dosing point in the vault. The new Chemical Facility (see Section 5.3.8) will include chemical storage and pumping facilities to replace the existing systems and to provide storage for MBR cleaning chemicals, alkalinity, and carbon sources, as required. The effluent pipeline has a retention time of 52 minutes at a max flow of 0.55 MGD and an average retention time of 118 minutes at the AA flow of 0.24 MGD, which provide adequate retention time for disinfection.



Figure 22 Existing Effluent Chlorination Dosing Point

The District and WSC considered the potential drivers to upgrade the disinfection system to ultraviolet (UV) disinfection:

- UV disinfection may only require chlorination to provide a residual in the effluent pipeline to mitigate biofilm formation, resulting in a decrease of chemical use.
- If the effluent pipeline was considered for conveyance to recycled water uses, the current contact time in the effluent pipeline to potential recycled water use points does not meet Title 22 regulatory requirements for tertiary disinfected recycled water use (450 mg/L-min) without significant chemical dosing and additional redundancy.

Recycled water use is not a driver of this project and the additional cost of upgrading to UV disinfection does not provide additional benefit towards meeting effluent requirements. Chlorine disinfection was selected as the preferred disinfection alternative, with future recycled water uses or changing effluent requirements being factors that could lead to disinfection upgrades in the future.

The existing dechlorination process at the effluent disposal site consists of dosing sodium bisulfite via dissolvable tablets in the filter underdrain before the outfall. To improve reliability of the dechlorination process and provide better process control, a sodium bisulfite dosing system will be constructed at the effluent disposal facility to provide storage, dosing through a chemical pump, and measurement of residual free chlorine. The existing sodium bisulfite dosing system will be replaced.

5.3.8 Chemical Facility

A new Chemical Facility will be constructed to provide storage, containment, and conveyance for chemicals required for the MBR process and on-site chlorination. Chemical storage will either be in totes, drums, or fixed tanks with refill connection points. Pumping units will be peristaltic type chemical pumps with compatible materials and appurtenances for the associated chemical. Peristaltic pumps were selected because they are less prone to clogging with no valving or impedance in flow path, and their wear parts can be easily replaced with minimal pump downtime. Each chemical storage space will have its own dedicated containment area and sump to minimize risk of chemical reactions from spills.

The Chemical Facility was sited along the access-egress route around the perimeter of the WRRF to allow for easy offloading and refilling of chemical storage. Siting of the Chemical Facility included review of California Fire Code and California Building Code requirements for separation distances for hazardous material storage. Additionally, the Chemical Facility was located central to the MBR and the Effluent and UW Pump Station to minimize lay length of sodium hypochlorite chemical dosing pipe, which can be prone to issues and safety concerns related to sodium hypochlorite off gassing.

Table 25 below includes a list of the chemicals that will or may be used at the WRRF, and design criteria for pumping and storage. Polymer used for solids dewatering is not included in Table 27 since it will be stored in the Dewatering Building. The 60% Design is based on the use of sodium hypochlorite for disinfection and membrane cleaning, and citric acid for membrane cleaning. The need for an alkalinity or external carbon source will be confirmed through additional process modeling. If those process chemicals are not required, space will be designed into the Chemical Facility to allow for addition of those chemical systems, should influent wastewater characteristics change and necessitate their use. The Chemical Facility will include one (1) additional secondary containment and storage space for future chemical storage needs.

Table 27 Chemical List and Facility Design Criteria

Chemical	Purpose	Pumping Units	Storage Quantity	Notes
Sodium Hydroxide 50%	Alkalinity Source for MBR Process	1 Duty	250 gal	Tote Storage
MicroC	External Carbon Source for Denitrification	1 Duty	250 gal	Tote Storage
Citric Acid 30%	Membrane Cleaning	1 Duty	55 gal	Drum storage
Sodium Hypochlorite 12.5%	Membrane Cleaning	1 Duty	250 gal	2,000-gallon tank storage shared with Disinfection supply
Sodium Hypochlorite 12.5%	Disinfection	2 Duty (Low and High Capacity)	1750 gal	2,000-gallon tank storage shared with Membrane Cleaning supply

5.4 Existing Facilities

The existing WWTP facilities will either be repurposed, replaced, relocated, or remain as-is. Details of the evaluation for future use of the existing facilities can be referenced in Chapter 2.0. Table 28 includes a summary of the changes or fate of the existing facilities onsite and offsite, some of which are previously discussed in this Chapter or elsewhere in the 60% Design Report.

Table 28 Changes to Existing Facilities for WRRF Upgrades

Existing Facility	Scope of Changes for WRRF Upgrades	PDR Section Reference
Pond 1	Pond 1 will be taken offline, cleaned, and its liner removed, then be repurposed as a storage yard area with an earthen driveway for vehicle access.	Sections 2.2 and 5.1
Pond 2	Pond 2 will be taken offline, cleaned, have its liner replaced, then be repurposed as the Equalization Basin.	Sections 2.2 and 5.1
Effluent Pump Station	The effluent pump station will be decommissioned, demolished, and replaced by the effluent pumping at the Effluent and UW Pump Station.	Sections 2.2 and 5.1
Pond 3	Pond 3 will remain in place as-is.	Section 2.3
Chlorine Chemical Storage	The chlorine chemical storage area and associated pumping and piping will be demolished and replaced with the new Chemical Facility.	Sections 2.2 and 5.3.7
Sand Filters	Sand Filters will be bypassed.	Section 2.3
Dechlorination	The existing dechlorination point will be removed and replaced with a new dechlorination facility.	Section 2.3 and 5.3.7
Outfall	The outfall will remain in place as-is.	Section 2.3
Hazardous Household Waste	This waste storage trailer is currently located at the center of the site and will be relocated toward the roundabout driveway off Heritage Road, southwest of the new Operations Building.	--
Laboratory	The laboratory will remain in place as-is for continued use.	Sections 2.2 and 5.1

5.5 Electrical, Instrumentation, and Control Facilities

The existing electrical system is a 400-amp, 480/277 VAC, electrical service from PG&E. The existing PG&E padmount transformer is 150 KVA, located adjacent to the access road just immediately northeast of the Laboratory. The electrical service is connected to a 400-amp metering switchboard containing PG&E watt-hour meter #1010760604. The metering switchboard was manufactured in January 2021 and installed at the same time as the existing Solar Field. The metering switchboard has a 400-amp main breaker, 200-amp feeder breaker connected to existing panelboard, two 20-amp breakers for an energy monitoring panel, and bus interconnection of the existing solar system. The existing Solar Field is rated at 163 kilowatts and will remain in service through construction and to supply power for the upgraded WRRF. The existing electrical service connected load is 182 amps. Figure 23 includes a Single Line Diagram for the existing WWTP.

The existing panelboard contains miscellaneous breakers, and is connected to the effluent pumps, the chemical facility, and the pond aerators. The existing instrumentation system includes dissolved oxygen analyzers, flow meters, and pump and motor controls. The existing control system includes an Opto 22 remote terminal unit and operator interface terminal to display pump data (status and run times), dissolved oxygen readings and setpoints, and alarms. The existing panelboard, instrumentation system, and existing control system will be demolished.

The duty load ampacity, for the proposed treatment improvements, is 618 amps. Therefore, the existing PG&E padmount transformer and 400-amp metering switchboard are too small to supply the upgraded WRRF power demands. A new 800-amp, 480/277 VAC, electrical service from PG&E is proposed for the WRRF Upgrades. PG&E will provide and install a new padmount transformer. The proposed electrical system shall include:

- 800-amp Metering Switchboard with automatic transfer switch (ATS)
- 500-kilowatt Standby Generator
- 800 amp Distribution Switchboard
- Miscellaneous MCCs
- Panelboards.

Refer to Figure 24 for the proposed Single Line Diagram for the upgraded WRRF.

The Metering Switchboard with ATS, the Distribution Switchboard, the MCCs, and 120/208 VAC Panelboards will be located within the proposed Electrical Building. The Standby Generator will be located next to the Electrical Building, in a manufacturer's sound attenuating and weatherproof enclosure.

Most of the electrical equipment will be housed within the Electrical Building, some MCCs and Panelboards shall be located closer to the connected loads. For example, the MBR process has over 20 motor loads; therefore, it is prudent to locate the MBR MCC at the facility. The electrical

equipment will be based on Eaton Cutler-Hammer. The Standby Generator will be sized to handle duty loads plus 20% for future loads and based on Caterpillar equipment.

At a minimum, all equipment shall meet the following applicable industry standards:

- Underwriters Laboratories
- National Electrical Code (2020)
- National Fire Protection Agency 820 (Latest Edition)
- NEMA, and local, State and Federal Regulations

All new equipment shall be acceptance tested per the latest NETA Acceptance Testing Specifications prior to energizing. Any existing equipment repurposed for the WRRF Upgrades shall be maintenance tested per the latest NETA Maintenance Testing Specifications prior to energizing. All vendor supplied equipment shall be field certified by the manufacturer after initial installation and prior to final operational testing.

The installing contractor shall provide short circuit, arc flash, and coordination studies. The low voltage equipment shall be specified with 65,000 ampere available interrupting current rating to provide sufficient protective device ratings prior to study approval.

The electrical design will implement arc flash reduction controls as appropriate and required by NFPA 70E and OSHA 29 CFR 1910.269. The design goal is to minimize the arc flash energy to 8 Calories/cm² or less; therefore, falling within Hazard Risk Category 2 personal protective equipment (PPE) limits, without the use of arc resistant equipment.

Interior and exterior lighting shall be LED type fixtures. The fixtures will be controlled by motion sensors, lighting controllers, and photocells to comply with Title 24 Part 6, of the California Energy Code. Electrical room lighting will be manually switched, not on motion sensors. Lighting levels shall be based on Illuminating Engineering Society (IES) guidelines. Emerging egress lighting and exit signs will be provided for the new buildings designed for 1 foot-candle average illumination with 90 minutes of battery capacity.

Exposed conduits shall be PVC coated galvanized rigid steel, except in non-process rooms (e.g., electrical rooms, control rooms, etc.) where exposed conduits shall be galvanized rigid steel. In office type environments, electrical metallic tubing with compression fittings are allowable. Underground conduits shall be non-metallic PVC Schedule 40 with concrete encasement. Embedded conduits (e.g., within concrete walls and floor slabs) shall be non-metallic PVC Schedule 40.

Low voltage power and control cables shall be 600 VAC, XHHW-2, 90 degree C, stranded copper conductors.

The instrumentation system will include a variety of instruments and analyzers as required for monitoring the various processes and equipment for the new facilities. The instruments shall be connected to new programmable logic controllers, which shall be programmed and allow for process automation based on District Operator setpoints. The PLCs will be specified to be a

single manufacturer supply (either Modicon or Allen-Bradley), including for the packaged systems, so the PLC control system is compatible throughout the facility.

A new SCADA system will be provided to allow for District Operator interface (e.g., commands and setpoints), process trending, system alarms, and data archiving. The District prefers Ignition SCADA software at the WRRF to match their use of Ignition for their drinking water system SCADA software. The SCADA hardware including computers and network switch shall reside in the Electrical Building but configured to allow for connection of remote SCADA stations. There shall be a remote SCADA station in the SCADA Room of the proposed Operations Building.

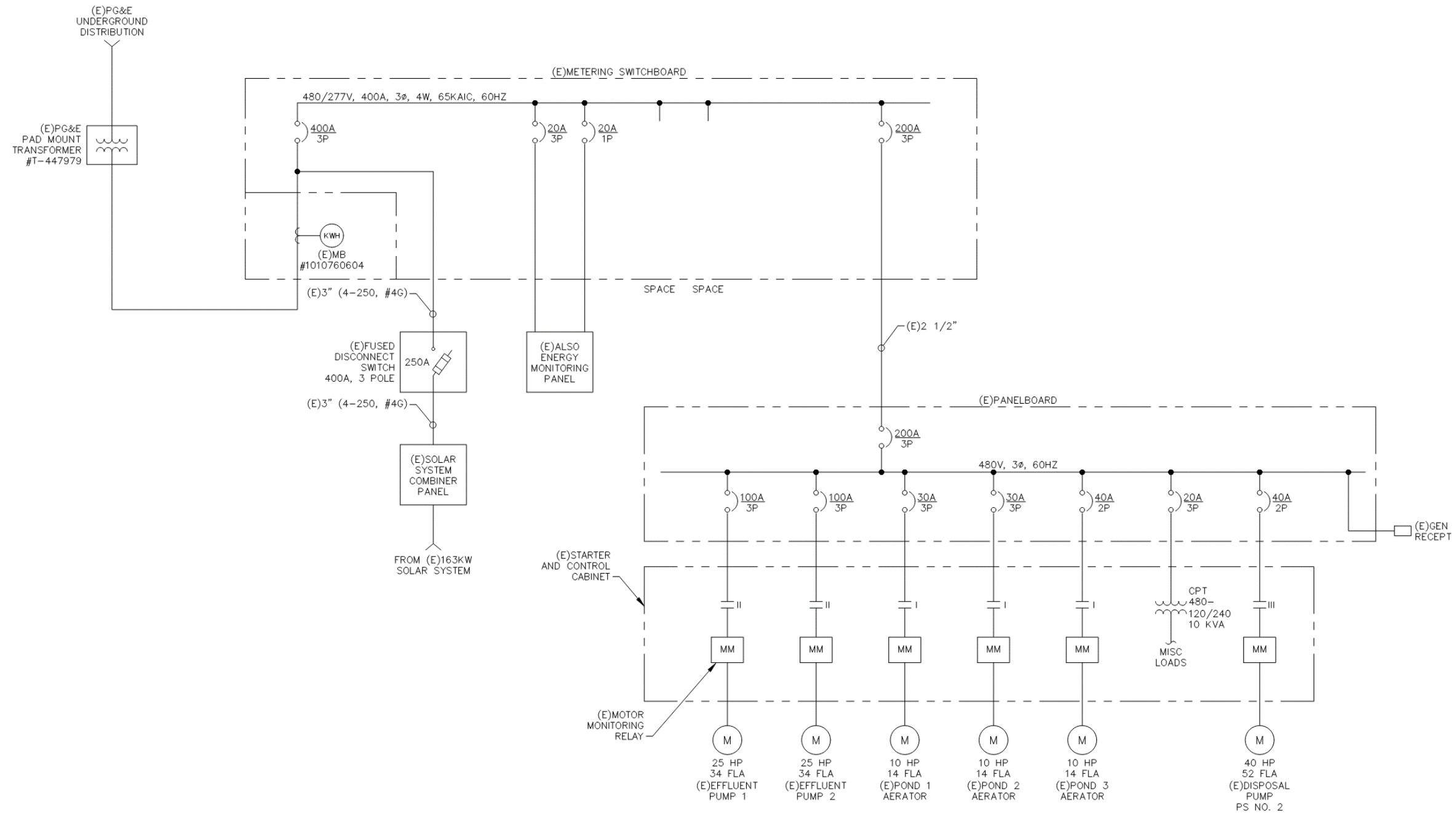

LOAD CALCULATIONS AT 480 VAC, 3 PHASE	
LOAD DESCRIPTION	AMPS
EFFLUENT PUMP 1 (25 HP)	34
EFFLUENT PUMP 2 (25 HP)	34
POND 1 AERATOR (10 HP)	14
POND 2 AERATOR (10 HP)	14
POND 3 AERATOR (10 HP)	14
CONTROL POWER TRANSFORMER (10 KVA)	20
DISPOSAL PUMP (40 HP)	52
SUBTOTAL:	182
25% CONTINUOUS LOAD:	46
TOTAL AMPS:	228

EXISTING SINGLE LINE DIAGRAM

Figure 23 Existing WWTP Single Line Diagram

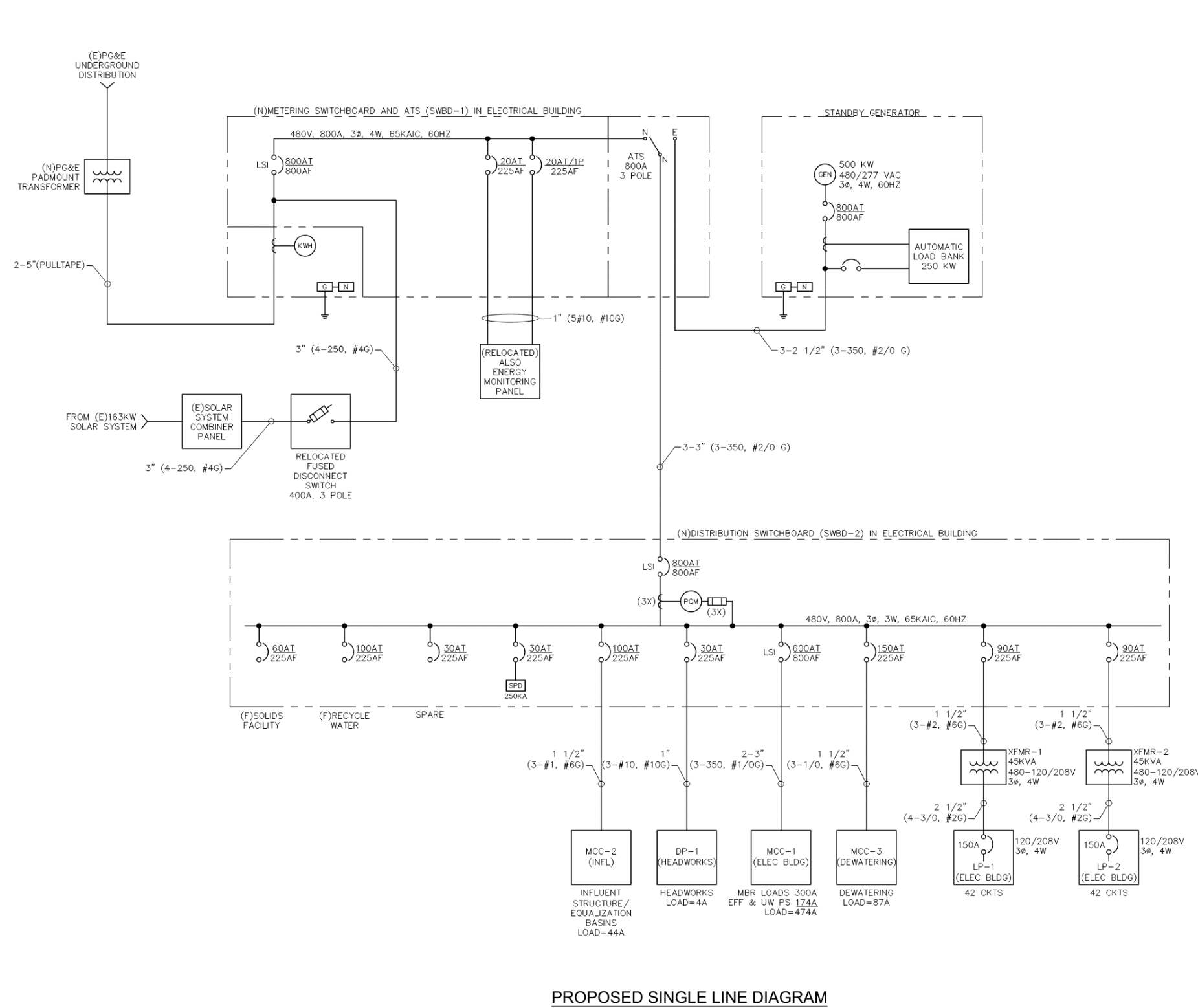

LOAD CALCULATIONS AT 480 VAC		
DESCRIPTION	CONNECTED AMPS	DUTY AMPS
INFLUENT STRUCTURE/ EQUALIZATION PUMPS		
EQUALIZATION BASIN PUMP 1 (7.5 HP)	11	11
EQUALIZATION BASIN PUMP 2 (7.5 HP)	11	(NOTE 1)
EQUALIZATION BASIN AERATOR 1 (7.5 HP)	11	11
EQUALIZATION BASIN AERATOR 2 (7.5 HP)	11	(NOTE 1)
SUBTOTALS	44	22
HEADWORKS		
COARSE SCREEN 1 (2 HP)	3.4	3.4
SUBTOTALS	3.4	3.4
PACKAGED MBR FACILITY		
FINE SCREEN GRIT REMOVAL (3 HP)	4.8	4.8
AIR DRYER (1 HP)	1.8	1.8
BLOWER 1 - BIOLOGICAL REACTOR (2C HP)	27	27
BLOWER 2 - BIOLOGICAL REACTOR (2C HP)	27	27
BLOWER 3 - BIOLOGICAL REACTOR (2C HP)	27	(NOTE 1)
BLOWER 1 - MEMBRANE (15 HP)	21	21
BLOWER 2 - MEMBRANE (15 HP)	21	21
BLOWER 3 - MEMBRANE (15 HP)	21	(NOTE 1)
AIR COMPRESSOR (7.5 HP)	11	11
ANOXIC TANK MIXER 1 (5 HP)	7.6	7.6
ANOXIC TANK MIXER 2 (5 HP)	7.6	7.6
DEOXYGENATION TANK MIXER 1 (3 HP)	4.8	4.8
DEOXYGENATION TANK MIXER 2 (3 HP)	4.8	4.8
WAS PUMP 1 (3 HP)	4.8	4.8
WAS PUMP 2 (3 HP)	4.8	(NOTE 1)
RAS PUMP 1 (7.5 HP)	11	11
RAS PUMP 2 (7.5 HP)	11	11
RAS PUMP 3 (7.5 HP)	11	(NOTE 1)
IMLR FLOW PUMP 1 (3 HP)	4.8	4.8
IMLR FLOW PUMP 2 (3 HP)	4.8	4.8
PERMEATE PUMP 1 (10 HP)	14	14
PERMEATE PUMP 2 (10 HP)	14	14
PERMEATE PUMP 3 (10 HP)	14	(NOTE 1)
WATER HEATER (12 KW)	19	(NOTE 1)
SUBTOTALS	299.6	202.8
CHEMICAL FACILITY		
HYPD DOSING PUMP 1 (0.25 HP)	0.5	0.5
HYPD DOSING PUMP 2 (0.25 HP)	0.5	(NOTE 1)
CAUSTIC DOSING PUMP 1 (0.25 HP)	0.5	0.5
CAUSTIC DOSING PUMP 2 (0.25 HP)	0.5	(NOTE 1)
ACID DOSING PUMP 1 (0.25 HP)	0.5	0.5
ACID DOSING PUMP 2 (0.25 HP)	0.5	(NOTE 1)
CARBON DOSING PUMP 1 (0.25 HP)	0.5	0.5
CARBON DOSING PUMP 2 (0.25 HP)	0.5	(NOTE 1)
WATER HEATER (40 KW)	60	(NOTE 1)
SUBTOTALS	64.0	2.0
DEWATERING FACILITY		
SLUDGE FEED PUMP 1 (3 HP)	4.8	4.8
SLUDGE FEED PUMP 2 (3 HP)	4.8	(NOTE 1)
DEWATERING UNIT (3 HP)	4.8	4.8
FLOC TANK MIXER (1 HP)	1.8	1.8
SLUDGE CONVEYOR (3 HP)	4.8	4.8
SPEED REDUCER (2 HP)	3	3.4
POLYELECTROLYTE PREP UNIT (1 HP)	1.8	1.8
POLYELECTROLYTE DOSING PUMP 1 (5 HP)	7.6	7.6
POLYELECTROLYTE DOSING PUMP 2 (5 HP)	7.6	(NOTE 1)
SOLIDS STORAGE TANK BLOWER 1 (5 HP)	7.6	7.6
SOLIDS STORAGE TANK BLOWER 2 (5 HP)	7.6	(NOTE 1)
ODOR CONTROL (7.5 HP)	11	11
WATER HEATER (12 KW)	19	(NOTE 1)
SUBTOTALS	86.6	47.6
EFFLUENT AND UW PUMP STATION		
EFFLUENT PUMP 1 (30 HP)	40	40
EFFLUENT PUMP 2 (30 HP)	40	40
EFFLUENT PUMP 3 (30 HP)	40	(NOTE 1)
UTILITY WATER BOOSTER PUMP 1 (20 HP)	27	27
UTILITY WATER BOOSTER PUMP 2 (20 HP)	27	(NOTE 1)
SUBTOTALS	174.0	107.0
MISC. ELECTRICAL LOADS		
120/208V TRANSFORMER 1 (45 KVA)	54	32.4
120/208V TRANSFORMER 2 (45 KVA)	54	32.4
OPERATIONS BUILDING	25	15
FUTURE LOADS (SOLIDS FACILITY)	100	80
SUBTOTALS	233.0	159.8
FUTURE SOLIDS HANDLING		
DIGESTION (20 HP)	27	27
THICKENING (10 HP)	14	14
SUBTOTALS	41.0	41.0
FUTURE RECYCLE WATER PUMPS		
RECYCLED WATER PUMP 1 (20 HP)	27	27
RECYCLED WATER PUMP 2 (20 HP)	27	27
SUBTOTALS	54.0	54.0
GRAND SUBTOTALS	1000	640
25% DUTY (CONTINUOUS) LOAD:	160	160
TOTAL LOAD:	800	800

NOTES:
1. DUTY LOAD, NOT PART OF CONTINUOUS LOAD CALCULATIONS.

Figure 24 Proposed Single Line Diagram for Upgraded WRRF

5.6 Building Programming

Building Programming for the WRRF Upgrades included site visits, discussions with District operators and maintenance staff, review of existing building purposes and needs, and determination of future facility building needs. The evaluation concluded that the existing Maintenance Building can be retrofitted for dedicated operator workspace, locker space, and sanitary facilities and a Table 29 provides a summary of the existing and new buildings and their future purpose for the upgraded WRRF facility.

Table 29 New and Existing Buildings for WRRF Upgrades

Building	Type	Purpose	Notes	Size (SF)
Laboratory (Existing)	Insulated wood frame building	Water quality analysis and process sample storage.	If the District elects to perform more water quality for their new WDR monitoring and reporting requirements than they do currently, some additional equipment or space within the existing footprint may be needed.	560
Storage Building (Existing)	Non-insulated metal building	Storage of miscellaneous equipment, trailer mounted standby generators, and spare parts.	The District operators use this space often and will preserve its use after the WRRF Upgrades. No changes to the current use of this space is anticipated.	2,100
Maintenance Building (Existing)	Insulated metal building with two separate two-story levels	Storage of equipment, maintenance workspace, space for bathroom, shower, lockers, and operator workstations.	The existing operator workstations, bathroom, and lockers do not provide adequate space for these functions. The building will be retrofitted to create additional space for these purposes.	1,600
Electrical Building	Prefabricated; performance specification design basis	Housing for process equipment MCCs and panelboards.	Common construction includes Class A fire rated polystyrene core with either vinyl-covered, painted steel, or FRP paneling. aluminum framed walls, and steel framed roofs.	800

5.7 Geotechnical Conditions

A site investigation was performed on October 26, 2022, to obtain soil samples and perform visual investigations of subsurface conditions from exploratory trenches throughout the WRRF site. This section summarizes the approach and results of the investigation, the details of which can be referenced in the Soils Engineering Report in Appendix E.

5.7.1 Approach

The soil samples and investigations obtained from the October 26, 2022 site investigations were used to explore and evaluate the surface and sub-surface soil conditions at the WRRF site and to develop geotechnical information and design criteria. The geotechnical study included the following work:

- A literature review of available published and unpublished geotechnical data pertinent to the WRRF site including geologic maps, and available online or from previously obtained aerial photographs.
- A field study consisting of site reconnaissance and subsurface exploration, including four exploratory trenches, to gain an understanding of the sub-surface conditions at the WRRF site.
- Laboratory testing on representative soil samples that were collected during the field study.
- Engineering analysis of the data gathered during our literature review, field study, and laboratory testing.
- Development of recommendations for site preparation and grading as well as geotechnical design criteria for drainage facilities.

The WRRF site trenching locations (T-1, T-2, T-3 and T-4) from the site investigation are shown in Figure 25.



Figure 25 Geotechnical Site Investigation Trenching Locations

5.7.2 Results

As further described in the Soils Engineering Report, the key observations and results from the geotechnical site investigation and laboratory testing include:

- Subsurface conditions of materials from the exploratory trenches included the following:
 - Fill was interpreted in T-2 from the surface to approximately 2.5 feet below ground surface (bgs). The fill material consisted of very dark grayish brown lean CLAY with sand (CL) encountered in a slightly moist condition, containing some debris and disturbed formational material. This material is likely associated with previous grading of the WRRF site.
 - Older Surficial Sediments (Qoa) were interpreted in T-1, T-3 and T-4 from the surface to approximately 3.5 to 11.0 feet bgs, and in T-2 from the bottom of the fill material at approximately 2.5 feet to approximately 13.0 feet bgs. The surficial native material consisted of very dark grayish brown lean CLAY with sand (CL) encountered in a dry to slightly moist and hard condition to depths ranging from approximately 1.5 to 6.0 feet bgs. The surficial material was underlain by dark yellowish brown lean CLAY with sand (CL) (T-1, T-3, and T-4) and dark yellowish brown sandy CLAY (CL) (T-3) encountered in moist and hard conditions to depths ranging from approximately 3.5 to 13.0 feet bgs.

- Each of the exploratory trenches was terminated in material of the Atascadero Formation (Kas) at depths ranging from 4.0 to 13.5 feet bgs. The formational material encountered in T-1, T-2, and T-3 consisted of grayish brown fine-grained SANDSTONE encountered in a slightly moist and very dense condition. The formational material encountered in T-4 consisted of yellowish brown coarse-grained SANDSTONE encountered in a dry and very dense condition. The formational material in T-4 could not be penetrated with the excavator used for the field investigation.
- Groundwater was not encountered during the field investigation.
- Based on the absence of groundwater during the field investigation, the depth to formational material, as well as the fines content and relative density of the in-situ soils, the potential for seismic liquefaction of soils at the WRRF site is very low.
- The near-surface materials at the Site are considered “moderately corrosive”. The chloride ion concentrations, sulfate ion concentrations and pH values of the soil materials at the WRRF site are deemed insufficient to damage reinforced concrete structures or mortar-coated steel.
- Based on the results from the in-situ tests performed during the field investigation, the seismic design parameters include:
 - Site Class: C “Very Dense Soil and Soft Rock”
 - Structure Risk Category: III
 - 1-Second Period Design Spectral Response Acceleration, S_{D1} : 0.393g
 - Short-Period Design Spectral Response Acceleration, S_{DS} , 0.865g
 - Site Specific MCE Peak Ground Acceleration, PGA_M : 0.555g
- It is anticipated that foundations for the proposed deep tank structures will be excavated into the uniform competent formational material encountered during the field investigation at depths ranging from approximately 3.5 to 13.0 feet bgs, with no further preparation required.

6.0 Staffing Requirements

A Staffing Plan for the upgraded WRRF was prepared to support the District's planning for WRRF staffing needs for operation, maintenance, and laboratory activities to maintain the facility on an annual basis.

IN THIS SECTION

- Approach
- Staffing Requirements
- Recommendations

6.1 Approach

The staffing estimates were assessed based on the New England Interstate Water Pollution Control Commission (NEIWPCC) staffing guide² (4), staffing at similar facilities in San Luis Obispo County, and feedback from practicing operators at California WRRFs. The NEIWPCC staffing guide was created using input from multiple facilities with a wide range of process flows, treatment processes, and staffing practices to create charts that estimate the total annual staffing hours required to operate and maintain a WWTP. This analysis incorporates the upgraded WRRF design flow, types of treatment processes, activities the operators and maintenance staff are responsible for, staffing shifts, and State Water Resources Control Board (SWRCB) code requirements.

The upgraded HRCSD WWTP would be classified as a Class III facility in accordance with California Code of Regulations, Title 23, Division 3, Chapter 26, assuming tertiary treatment provided by a membrane bioreactor (MBR). Per the SWRCB, the following staffing structure is required:

- “The CPO is the operator responsible for the overall operation of the WWTP and must be a certified WWTP operator at the same grade of, or higher than the level of classification of the WWTP.” (e.g., Grade III for the upgraded HRCSD WWTP)
- “The DOIC is a certified operator appointed by the CPO to be responsible for the overall operation of a WWTP, including compliance with the applicable waste discharge requirements when the CPO is unable to carry out the responsibilities of the position. The DOIC reports directly to the CPO.” Class III facilities require the DOIC to be a Grade II WWTP Operator.

6.2 Staffing Requirements

The results of this analysis indicate the upgraded HRCSD WWTP requires 2.5 full-time equivalent (FTE) employees to operate the WWTP five (5) days a week, or 3 FTE employees if it is staffed seven (7) days a week. The days of operation are dependent on the sophistication of the SCADA system, final permit requirements, and HRCSD’s preferred staffing strategy. These staffing estimates include Laboratory Operations which account for approximately 0.5 FTE for both staffing scenarios. Table 30 provides a summary of the hourly and annual operations, maintenance and laboratory activities based on the NEIWPCC staffing guide and WSC’s engineering judgment, and Table 31 includes a summary of the staffing estimate by category using the estimates from Table 30.

² New England Interstate Water Pollution Control Commission (NEIWPCC), The Northeast Guide For Estimating Staffing at Publicly And Privately Owned Wastewater Treatment Plants.

Table 30 Staffing Requirements by Process or Activity

Basic and Advanced Operations and Processes			
Process/Activity	Hours/Day	Hours/Year	Notes
Preliminary Treatment	0.50	130	Headworks
Activated Sludge with BNR	3.00	780	MLE
Nitrification	0.25	65	
Denitrification	0.25	65	
Membrane Processes	0.25	65	
Plant Reuse Water	0.10	26	
Chlorination	0.50	130	
Dechlorination	0.50	130	
Dry Odor Control	0.25	65	For Dewatering
Maintenance			
Process/Activity/Flow	Hours/Day	Hours/Year	Notes
Manually Cleaned Screen (1)	0.25	65	
Mechanical Coarse Screens (1)	0.25	65	
Additional Process Tanks (1)	0.10	26	Equalization Basin
Chemical Addition (3)	0.10	78	MBR Carbon Source and Membrane Cleaning
Pumps	-	100	For all Pumps
Mechanical Mixers (2)	0.10	52	MBR Tanks
Aeration Blowers (6)	0.20	312	MLE and Membranes
Membrane Bioreactors (8)	0.10	208	Eight (8) modules
Mechanical Dewatering (1)	0.15	39	Screw Press
Liquid Chlorination	0.20	52	
Liquid Dechlorination	0.20	52	
Probes/Instrumentation/Calibration (10)	0.10	260	
Laboratory Operations			
Process/Activity/Flow	Hours/Test	Hours/Year	Notes
Alkalinity	0.75	39	Weekly
Ammonia	2	104	Weekly
BOD	2.5	130	Weekly
Chlorine, Total Residual	0.25	13	Weekly
Total and Fecal Coliform	1	104	Twice Weekly
Dissolved Oxygen	0.25	3	Monthly
pH	0.25	3	Monthly
QA/QC Program – Laboratory	1	52	Weekly
Temperature	0.25	3	Monthly
Total Suspended Solids	3	156	Monthly
Sampling for Contracted Lab Services	-	50	General Coordination
Biosolids/Sludge Handling			
Process/Activity/Flow	Hours/Day	Hours/Year	Notes
Screw Press (1)	0.25	65	
Transported Off-Site for Disposal	0.25	65	
Sitework			
Process/Activity/Flow	Hours/Activity	Hours/Year	Notes
General Site and Vehicle Maintenance	--	104	2 hours per week
Automation/SCADA			
Process/Activity/Flow	Hours/Day	Hours/Year	Notes

SCADA	0.25	65	
-------	------	----	--

Table 31 Upgraded WRRF Staffing Requirements Summary

Staffing Category	5-day Per Week Staffing	7-day Per Week Staffing
Basic and Advanced Operations and Processes	1,456	1,792
Maintenance	1,309	1,588
Laboratory Operations	657	657
Biosolids/Sludge Handling	130	160
Sitework	104	104
Estimated Operation and Maintenance Hours	3,656	4,381
TOTAL STAFFING ESTIMATE¹	2.44	2.87

¹Total Staffing Estimate is calculated by dividing the total of Annual Hours by 1,500 hours per year to get the estimated staff needed to operate the WWTP. This assumes 5-day work week; 29 days of vacation, sick leave, and holidays; and 6.5 hours per day of productive work.

Currently, there are three (3) trained personnel who adequately operate the HRCSD WWTP. Their names, grade, and certification numbers are shown in Table 32.

Table 32 HRCSD WWTP Personnel FY22

Name	Grade and Certification No.
Roy Arnold	I, 28702
Mark Humphrey, Jr.	OIT-1
Brian Vogel	OIT-1

6.3 Recommendations

It is recommended that HRCSD staff three (3) operations and maintenance staff to operate and maintain the HRCSD WWTP. Based on SWRCB WWTP staffing requirements and the estimates from this Staffing Plan, HRCSD WWTP staff would include one (1) Grade III CPO, one (1) Grade II DOIC, and one (1) Grade II Operator for year-round staffing. Due to confined space entry methods, on-call staffing needs, ongoing and unplanned maintenance, and process optimization responsibilities, it is not recommended the HRCSD WWTP is staffed with less than 3 FTE operations and maintenance staff.

7.0 Implementation

This PDR represents a preliminary design level of the WRRF Upgrades with the remainder of the project to include final design, construction, and startup of the new facility. This chapter captures key implementation considerations including requirements for the existing facility to remain in operation through construction, the schedule, project cost, and next steps.

IN THIS SECTION

- Continuation of Existing Operations
- Design and Construction Schedule
- Project Cost Opinion
- Next Steps

7.1 Continuation of Existing Operations

The most significant engineering constraint of the WRRF Upgrades implementation is the need for the existing facilities to remain in operation to meet treatment requirements through construction. Both treatment ponds are required for consistent treatment, specifically during winter months. Aerated treatment pond systems do not allow for bypassing or cost-effective temporary operations with temporary treatment facilities to reliably meet permit limits for the duration of the construction period. Preliminary sequencing plans include either:

- A) Adding aerator capacity to Pond 1 and implementing short-term treatment improvements to maximize treatment capacity while improvements are made to convert Pond 2 into the Equalization Basin toward the end of the construction period; or
- B) Operating Pond 1 as temporary equalization while Pond 2 is converted to the Equalization Basin, following completion of the WRRF Upgrades.

As the WRRF Upgrades design progresses, WSC will coordinate with the District and the CCRWQCB to define operational sequencing in alignment with construction activities. The requirements for operational sequencing will be captured in the technical specifications for the project design documents.

7.2 Design and Construction Schedule

The progression of the design and construction schedule for the WRRF Upgrades is driven by or dependent on the following factors:

- The CCRWQCB TSO R3-2022-0046 milestone requirements.
- USDA review of design deliverables and approval of design documents against USDA Water & Waste Disposal Loan & Grant Program requirements.
- Equipment procurement for long-lead equipment and project bidding schedules (discussed further in Section 7.2.1).
- Constructability of the WRRF Upgrades and reasonable expectation of construction timelines for the nature of the improvements being constructed.
- Startup and commissioning requirements for an upgraded WRRF.

The timelines and critical path relationships between these activities were considered in the development of a design and construction schedule that incorporates these elements. A block diagram schedule of the various project activities is included in Figure 26 that captures project implementation through startup and commissioning of the upgraded WRRF. TSO milestone actions and compliance submittal dates can be referenced on pages 7 through 9 of the TSO, which is included in Appendix A.

Heritage Ranch WRRF Improvements Schedule



Permitting
 ROWD Application: March 2022 – June 2022
 TSO Renewal: July 2022 – November 2022
 NPDES Permitting: April 2025 – December 2026

Design
 PDR: April 2022 – December 2022
 60% Design: October 2023
 Final Design: January 2023 – December 2024
 Equipment Procurement: April 2024 – September 2024
 Bidding and Award: January 2025 – April 2025

USDA
 PER: March 2024
 USDA PER Review: April 2024 – July 2024
 USDA Design Document and Equipment Procurement Review: April 2024 – January 2025

Construction
 WRF Improvements: March 2025 – January 2027
 30% Construction Complete: October 2025
 80% Construction Complete: October 2026

Commissioning
 Upgraded WRF Operations: February 2027 – September 2027

Figure 26 WRRF Upgrades Design and Construction Schedule

7.2.1 Equipment Procurement

The WRRF Upgrades includes fabricated and specific long-lead equipment that is integral to the treatment process, including the Headworks screens, the dewatering screw press skid, and the Packaged MBR equipment. Given the advantages that can be realized from pre-procuring long-lead equipment, such as reducing construction timelines and change order potential, securing lower equipment costs prior to project bidding, and coordinating equipment specific design features during the design phase, the District elected to pre-procure the Packaged MBR equipment. This decision was further reinforced by the current supply chain disruptions and price volatility that has impacted the water-wastewater market.

Some of the key features of a pre-procurement contract for long-lead equipment specific to the WRRF Upgrades project includes:

- Performance based specifications that stipulate treatment or performance requirements of the supplied equipment.
- Warranty terms and options for the District's selection.
- Milestone completions to align equipment supplier's schedule with TSO milestones and key project milestones.
- Design phase and construction phase submittal requirements.
- EJCDC Contract, American Iron and Steel (AIS), and Build America, Buy America (BABA) requirements to comply with USDA terms for a federally funded project.
- Roles and responsibilities between designer and equipment supplier.
- Payment terms and conditions, and future procurement contract assignment conditions (e.g., procurement contract being assigned to the WRRF Upgrades contractor).

Execution of a pre-procurement contract will be preceded by a Request for Proposal (RFP) process to solicit equipment supply proposals from qualified Packaged MBR Sellers. Proposers would be shortlisted and offered interview opportunities to further present their equipment and service offerings to the District and WSC, followed by a best and final offer (BAFO) request to provide final pricing before the District selects an equipment supplier. Release of the Package MBR equipment pre-procurement RFP to potential Sellers is pending USDA's review of the draft contract documents and specifications.

7.3 Project Cost Opinion

A Class 2 AACE project cost opinion for the WRRF Upgrades was developed based on the 60% design level work performed as part of preparation of this Report, as summarized in Table 33. Costs were quantified in November 2023 dollars using the following data sources:

- Current vendor quotes, inclusive of tax and freight.
- Recent project bids from similar projects or for similar systems and equipment.
- Parametric estimating and escalation from similar projects (completed in last 5 years).
- Unit quantity takeoffs and unit costs.

The cost opinion does not include escalation to the midpoint of construction or any of the District's administrative costs or engineering costs.

Table 33 Class 2 Project Cost Opinion

CAPITAL COST		
Cost Item	Cost Basis	Nov 2023 Dollars
Sitework	LS	\$ 1,420,500
In-Plant Return Pump Station	LS	\$ 208,000
Headworks	LS	\$ 520,000
Influent Splitter Box	LS	\$ 63,000
Equalization Basin and Pump Station	LS	\$ 1,301,000
Packaged MBR System	LS	\$ 5,454,100
Chemical Storage Area	LS	\$ 482,000
Dewatering System	LS	\$ 1,044,300
Effluent and Utility Water Pump Station	LS	\$ 1,047,000
Electrical, Instrumentation and Control	LS	\$ 3,580,000
Effluent Pipeline	LS	\$ 692,000
Building Retrofits	LS	\$ 108,000
	Subtotal	\$ 15,919,900
Contractor OH&P and General Conditions	18.5%	\$ 2,946,000
	Construction Cost Subtotal	\$ 18,866,000
ESDC and CM	15%	\$ 2,829,900
Construction Contingency and Unaccounted for Costs	15%	\$ 2,829,900
	Total Capital Cost	\$ 24,526,000

The cost opinion presented above is an opinion of probable construction costs for estimation purposes based on an AACE Class 2 cost estimate with an accuracy range of -15% to +20%. Costs and assumptions used are based on quotes from manufacturers, recent bid estimates and industry cost data. The cost opinion is limited to the conditions existing at issuance and is not a guaranty of actual price or cost for the project. Uncertain market conditions such as, but not limited to labor availability, availability of qualified contractors, wages, other work, market changes for materials and equipment, price escalations, force majeure events, developing bidding conditions, etc. may affect the accuracy of this estimate.

7.4 Next Steps

This Report represents the 60% Design Report TSO milestone action, which is to be submitted to the CCRWQCB by November 15, 2023. The next project milestone per the TSO is completion and submission of the Final Design Report (e.g., plans and specifications) to the CCRWQCB by April 15, 2024. Prior to completion of the Final Design Report, there are several milestones that will be tracked internally by the District and WSC to advance the project:

- Incorporation of USDA review comments on the Draft Preliminary Engineering Report (PER) and submission of the Final PER to secure funding commitments from USDA.
- Completion of the 100% design by March 2024.
- Adoption of the District's sewer service rate increases to support funding of the project.

Additional permitting and environmental next steps and milestones are captured in the subsections below, as well as key remaining design decisions that will impact implementation of the WRRF Upgrades.

7.4.1 Permitting

In addition to the permitting coordination efforts between the District and the CCRWQCB, coordination with the County of San Luis Obispo (County of SLO) and the San Luis Obispo County Air Pollution Control District (SLO APCD) is required to obtain permit for construction of the WRRF Upgrades and operation of the WRRF.

The District will participate in a project intake meeting with the County of SLO in early 2023 to discuss permitting requirements for land use, grading, and building construction and occupancy. As the lead agency for the project, the District is not anticipating needing a Land Use Permit based on interpretation of the Government Code Section 53091, which states:

“building and zoning ordinances of a county or city shall not apply to the location or construction of facilities for the production, generation, storage, treatment, or transmission of water”.

A grading permit for site preparation and building permits for both the electrical improvements and the Operations Building are anticipated to be required and will be coordinated between the District and the County of SLO to obtain these permits, as needed.

Authority to Construct and Permit to Operate permits will be required for construction and operation of the WRRF and the diesel-powered Standby Generator by the SLO APCD. Coordination for execution of these permits will be initiated once details of energy use and quantification of potential air pollution sources are defined later in design.

7.4.2 Environmental

The District's environmental consultant has completed a Historic Property Identification Report, a Biological Resources Assessment, and a Paleontological Resources Assessment for the WRRF Upgrades site and the Effluent Disposal Site. Following completion of these assessments, an Initial Study (IS) was prepared to describe the environmental impacts of the proposed project and suggests mitigation measures where necessary to reduce impacts to biological resources, cultural resources, paleontological resources, hazards and hazardous materials, noise, transportation, and wildfire to less-than-significant levels.

The proposed mitigation measures identified in the IS will be implemented as part of the project such that the project will not generate a significant adverse impact on the environment during construction and operation. The finding for insignificant adverse impact on the environment for this project resulted in preparation of a Mitigated Negative Declaration (MND). The Draft Initial Study-Mitigated Negative Declaration (IS-MND) is anticipated to be released for public review and comment in early 2023, with subsequent adoption of the IS-MND. Adoption of the IS-MND is required before any improvements to the WRRF site or Effluent Disposal Site can begin.

7.4.3 Design Phase

The WRRF Upgrades described in this Report will be carried forward into a final design with subsequent 90% and 100% design deliverables prior to preparing bid set documents for public bid. Details of the design may be modified and optimized; however, the main WRRF Upgrades and technology selections described herein are considered final unless significant funding or regulatory changes impact the project requirements.

The remaining detailed design decisions are related to aspects of the Packaged MBR design that are the responsibility of the Seller that will be awarded the Package MBR pre-procurement contract, such as chemical needs, integrations with other process facilities, and scope of supply.

REFERENCES

1. **Michael K Nunley & Associates.** *Heritage Ranch Community Services District Wastewater Treatment Plant Operations and Maintenance Manual.* 2017.
2. —. *Heritage Ranch Community Services District Wastewater Treatment Plant Improvements Preliminary Engineering Memorandum, Rev. 1.* 2021.
3. **Metcalf & Eddy.** *Wastewater Engineering Treatment and Resource Recovery.* Fifth. New York : McGraw-Hill Education, 2014.
4. **New England Interstate Water Pollution Control Commission.** The Northeast Guide for Estimating Staffing at Publicly and Privately Owned Wastewater Treatment Plants. [Online] 2008.
5. **Michael K Nunley & Associates.** *Heritage Ranch Community Services District Recycled Water Study.* 2017.

HERITAGE RANCH COMMUNITY SERVICES DISTRICT



CONSTRUCTION DRAWINGS FOR WATER RESOURCE RECOVERY FACILITY UPGRADE 60% DESIGN

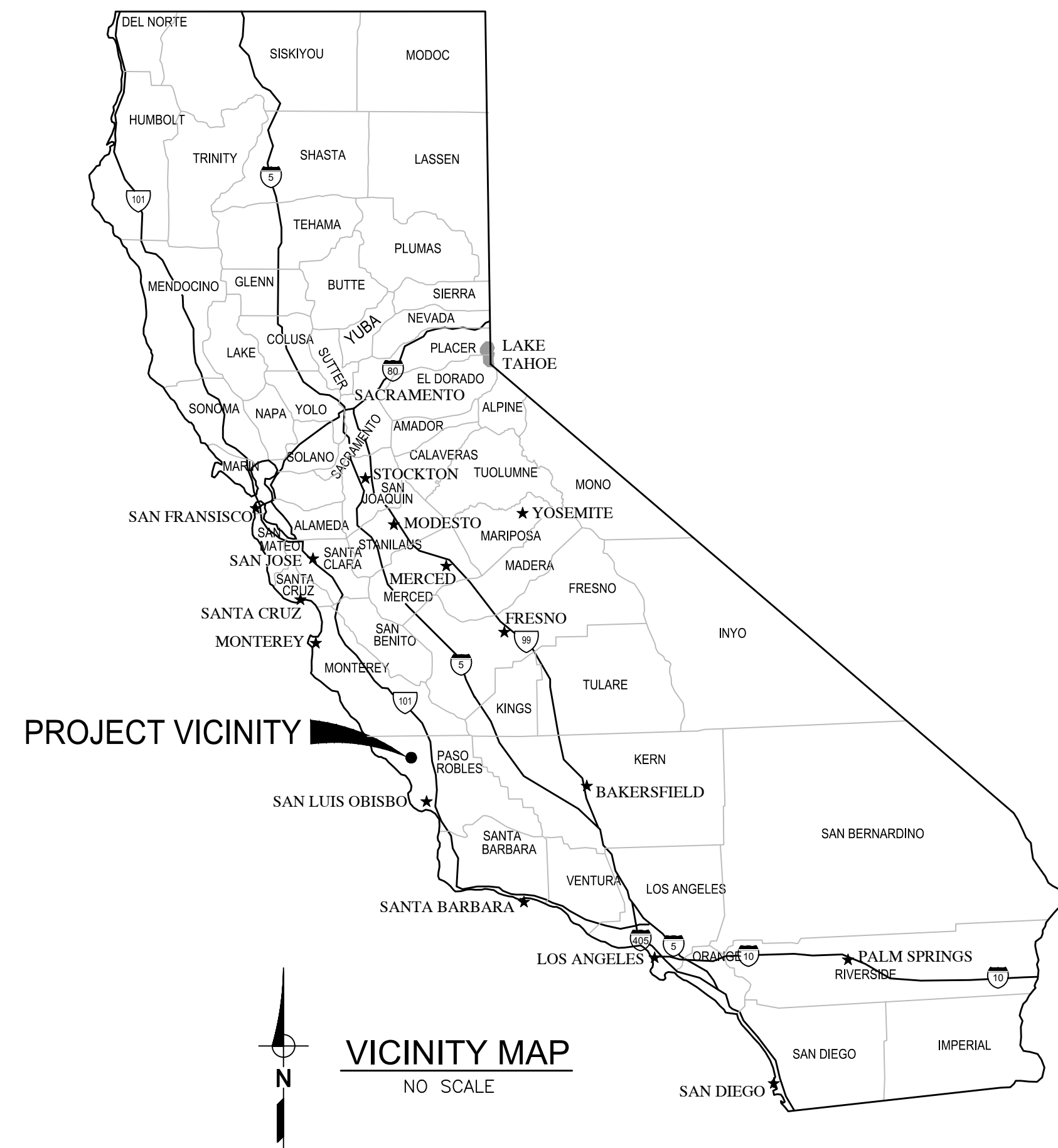

GOVERNING BOARD

BILL BARKER	PRESIDENT
DAN BURGESS	VICE PRESIDENT
DEVIN CAPPS	DIRECTOR
MICHAEL CAMOU	DIRECTOR
MASEN YAFFEE	DIRECTOR

CONTACT LIST

TITLE	NUMBER	CONTACT
HRCSD GENERAL MANAGER	(805) 227-6230	SCOTT DUFFIELD
HRCSD DISTRICT ENGINEER	(805) 227-6230	DOUG GROSHART
PASO ROBLES FIRE DEPT	(805) 227-7560	
SAN LUIS OBISPO COUNTY SHERIFF	(805) 434-4290	

PROJECT ADDRESS

4870 HERITAGE ROAD
PASO ROBLES, CA 93446

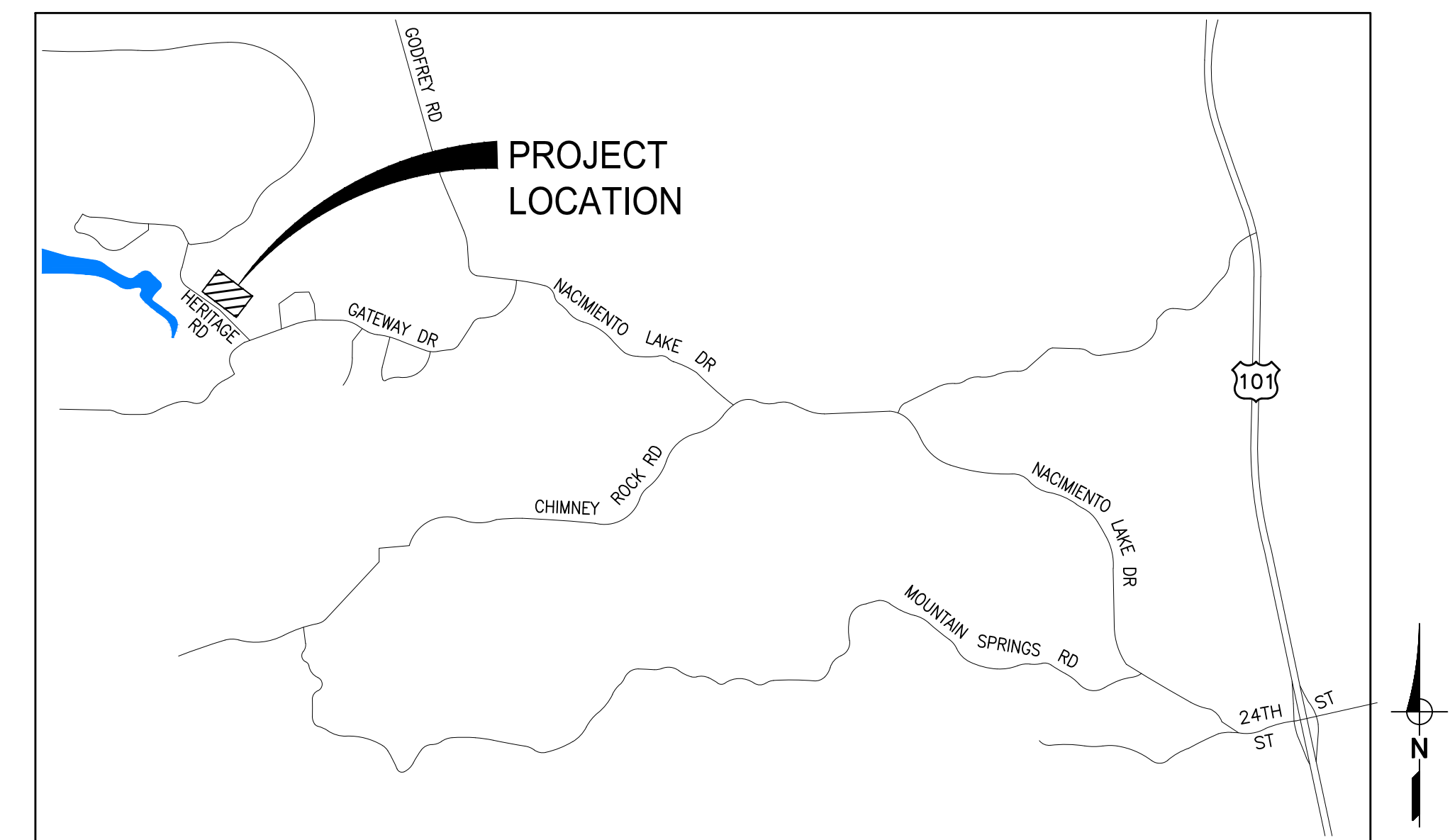

DRAFT - NOT FOR CONSTRUCTION

W:\3.0 Clients\Heritage Ranch Community Services District 1029\10090 WRF Upgrade Design\6.0 Working Files\0-CAD\1-SHEET FILES\G-HRCSD-WWTP - Gen.dwg 11/10/2023 2:14 PM Lauren Cetin

REV	DATE	BY	DESCRIPTION

WARNING
0 1/2 1
IF THIS BAR DOES NOT MEASURE 1" THEN DRAWING IS NOT TO SCALE.

DESIGNED	EKW
DRAWN	PMD
CHECKED	MNR
SCALE	AS NOTED

PREPARED BY:
MATTHEW N. RODRIGUES
RCE No.: 84311

DATE

605 AEROVISTA PLACE, SUITE 201
PHONE: (805) 457-8833

SAN LUIS OBISPO, CA 93401
FAX: (805) 888-2764

HERITAGE RANCH COMMUNITY SERVICES DISTRICT
4870 HERITAGE ROAD
PASO ROBLES, CA 93446

APPROVED: _____ POSITION _____ DATE _____

WATER RESOURCE RECOVERY FACILITY UPGRADE
GENERAL
TITLE SHEET, VICINITY MAP, AND LOCATION MAP

DRAWING
G-001
SHEET X OF X
PROJECT # _____

W:\3.0 Clients\Heritage Ranch Community Services District\1029\10090 WRF Upgrade Design\6.0 Working Files\0-CAD\1-SHEET FILES\G-HRCSO-WWTP - Gen.dwg 11/10/2023 4:42 PM Chris Durbin

SHEET NO. DWG NO. DRAWING TITLE

GENERAL

- 1 G-001 TITLE SHEET, VICINITY MAP, AND LOCATION MAP
- 2 G-002 SHEET INDEX
- 3 G-003 LEGEND AND SYMBOLS
- 4 G-004 ABBREVIATIONS
- 5 G-601 HYDRAULIC PROFILE
- 6 G-602 PROCESS FLOW DIAGRAM

SITework

- 7 01-C001 CIVIL NOTES 1
- 8 01-C002 CIVIL NOTES 2
- 9 01-C101 EXISTING SITE CONDITIONS
- 10 01-C102 SITE PLAN
- 11 01-C103 YARD PIPING PLAN

MECHANICAL

- 12 01-M101 IN-PLANT RETURN PUMP STATION PLANS
- 13 01-M301 IN-PLANT RETURN PUMP STATION SECTIONS AND DETAILS
- 14 02-M101 HEADWORKS PLAN
- 15 02-M301 HEADWORKS SECTIONS
- 16 03-M101 EQUALIZATION BASIN PLAN
- 17 03-M301 EQUALIZATION BASIN SECTIONS AND DETAILS
- 18 03-M101 EQUALIZATION BASIN PUMP STATION PLAN AND SECTION
- 19 03-M301 EQUALIZATION BASIN PUMP STATION SECTIONS
- 20 05-M101 CHEMICAL STORAGE AREA PLAN
- 21 05-M301 CHEMICAL STORAGE AREA SECTIONS
- 22 06-M101 DEWATERING PLAN
- 23 06-M301 DEWATERING SECTIONS
- 24 07-M101 EFFLUENT AND UTILITY WATER PUMP STATION PLAN
- 25 07-M301 EFFLUENT AND UTILITY WATER PUMP STATION SECTION
- 26 07-M302 EFFLUENT AND UTILITY WATER PUMP STATION SECTIONS

ELECTRICAL

- 27 00-E001 ELECTRICAL NOTES, SYMBOLS AND ABBREVIATIONS
- 28 00-E601 EXISTING SINGLE LINE DIAGRAM
- 29 00-E602 PROPOSED SINGLE LINE DIAGRAM
- 30 00-E701 ELECTRICAL DETAILS 1
- 31 00-E702 ELECTRICAL DETAILS 2

INSTRUMENTATION

- 32 00-N001 INSTRUMENTATION LEGENDS, ABBREVIATIONS, AND NOTES
- 33 00-N601 EMERGENCY EYEWASH AND SHOWER P&ID
- 34 02-N601 HEADWORKS P&ID
- 35 03-N601 EQUALIZATION BASIN P&ID
- 36 03-N602 EQUALIZATION BASIN PUMP STATION P&ID
- 37 04-N601 REPRESENTATIVE MBR EQUIPMENT PACKAGE P&ID
- 38 05-N601 CHEMICAL STORAGE AREA SYSTEM P&ID 1
- 39 05-N602 CHEMICAL STORAGE AREA SYSTEM P&ID 2
- 40 06-N601 DEWATERING SCREW PRESS SYSTEM P&ID 1
- 41 06-N602 DEWATERING SCREW PRESS SYSTEM P&ID 2
- 42 06-N603 DEWATERING SCREW PRESS SYSTEM P&ID 3
- 43 07-N601 EFFLUENT AND UTILITY WATER PUMP STATION P&ID
- 44 07-N602 UTILITY WATER DISTRIBUTION SYSTEM P&ID

DRAFT - NOT FOR CONSTRUCTION

	<p>WARNING</p> <p>IF THIS BAR DOES NOT MEASURE 1" THEN DRAWING IS NOT TO SCALE.</p>	<p>DESIGNED: <u> EKW </u></p> <p>DRAWN: <u> PMD </u></p> <p>CHECKED: <u> MNR </u></p> <p>SCALE: <u> NO SCALE </u></p>	<p>PREPARED BY:</p> <p>MATTHEW N. RODRIGUES RCE No.: 84311</p> <p>DATE</p>		<p>805 AEROVISTA PLACE, SUITE 201 PHONE: (805) 457-8833</p> <p>SAN LUIS OBISPO, CA 93401 FAX: (805) 888-2764</p>	<p>HERITAGE RANCH COMMUNITY SERVICES DISTRICT 4870 HERITAGE ROAD PASO ROBLES, CA 93446</p> <p>APPROVED:</p> <p>_____ POSITION _____ DATE</p>	<p>WATER RESOURCE RECOVERY FACILITY UPGRADE</p> <p>GENERAL</p> <p>SHEET INDEX</p>	<p>DRAWING</p> <p>G-002</p> <p>SHEET <u> X </u> OF <u> X </u></p> <p>PROJECT # <u> - </u></p>																				
<table border="1" style="width: 100%; border-collapse: collapse;"> <thead> <tr> <th>REV</th> <th>DATE</th> <th>BY</th> <th>DESCRIPTION</th> </tr> </thead> <tbody> <tr><td> </td><td> </td><td> </td><td> </td></tr> <tr><td> </td><td> </td><td> </td><td> </td></tr> <tr><td> </td><td> </td><td> </td><td> </td></tr> <tr><td> </td><td> </td><td> </td><td> </td></tr> </tbody> </table>	REV	DATE	BY	DESCRIPTION																								
REV	DATE	BY	DESCRIPTION																									

DRAWING NUMBER LEGEND

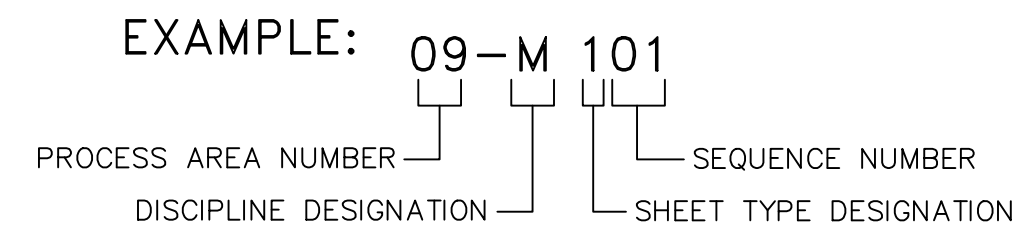

DISCIPLINE DESIGNATIONS

- G GENERAL
- C CIVIL
- M MECHANICAL
- E ELECTRICAL
- S STRUCTURAL
- I INSTRUMENTATION

SECTIONS AND DETAIL NUMBERING SYSTEM

SECTION CUT ON PLAN

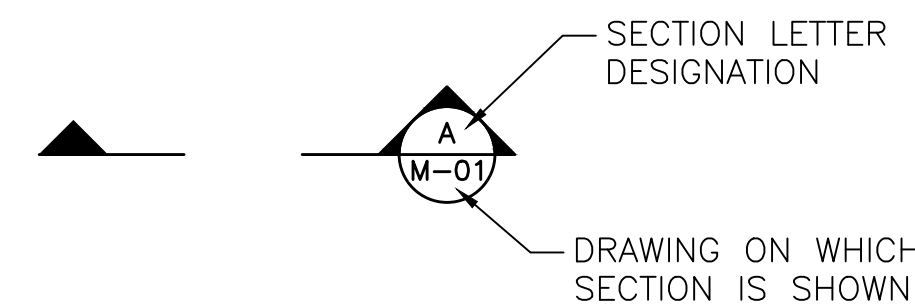

SECTION SHOWN

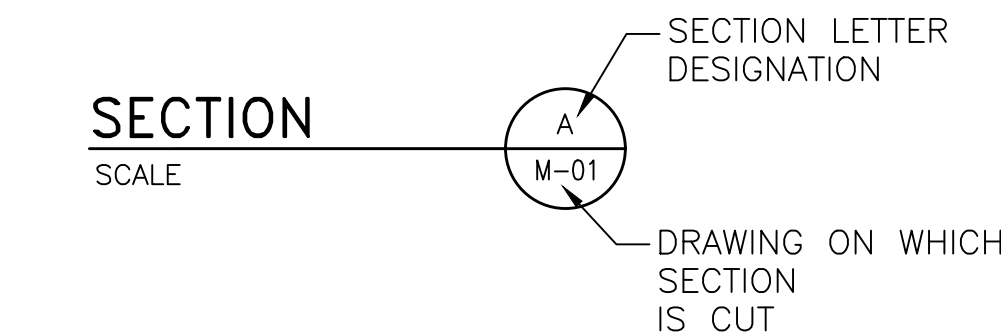

DETAIL NUMBERING SYSTEM

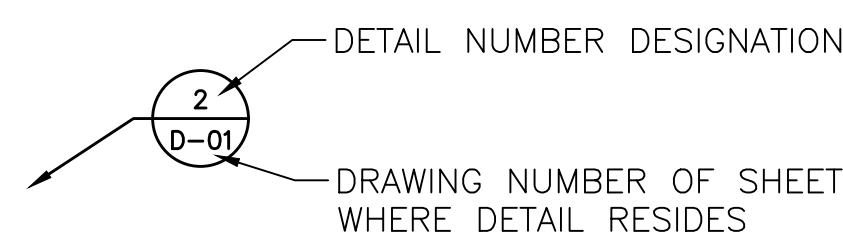

TYPICAL DETAILS

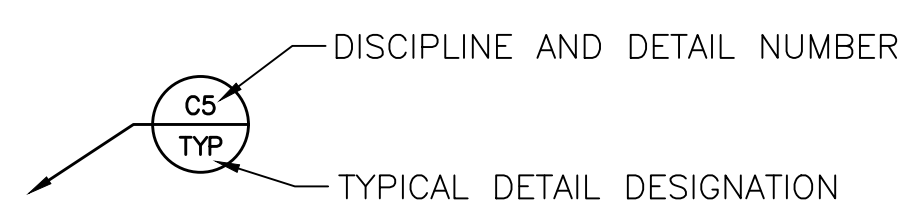

EQUIPMENT TAG NAMING

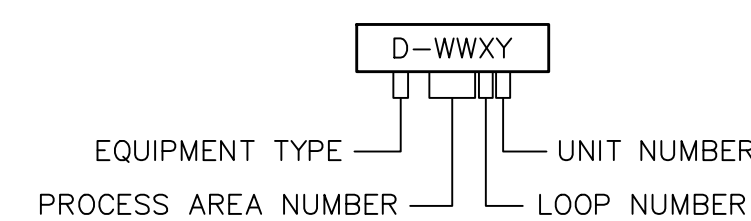

EQUIPMENT TYPE

- B BLOWER
- C COMPRESSOR
- EW H ELECTRIC WATER HEATER
- G GATE
- M MECHANICAL EQUIPMENT
- P PUMP
- SF SUPPLY FAN
- SG SLIDE GATE
- T TANK
- WG WEIR GATE

LEGEND:

EXISTING

- SURVEY MONUMENT
- CENTERLINE
- EASEMENT LINE
- PROPERTY LINE
- RIGHT OF WAY
- STORM DRAIN
- WATERLINE
- SANITARY SEWER
- RECYCLED WATER
- TELEPHONE
- FIBER OPTIC
- GAS
- OVERHEAD UTILITIES
- ELECTRICAL
- CABLE TV
- EDGE OF PAVEMENT
- FENCE
- GAS VALVE OR HAND HOLE
- FIRE HYDRANT ASSEMBLY
- WATER VALVE
- WATER SERVICE
- FIRE SERVICE
- STORM DRAIN MANHOLE
- TELEPHONE MANHOLE
- ELECTRIC MANHOLE
- SEWER MANHOLE
- GAS METER
- AIR VAC
- BLOW OFF
- REDUCER
- UTILITY PULL BOX
- POWER POLE
- LIGHT POST
- SIGN
- TREE
- BUSH/TREES/BRUSH

- STEEL IN SECTION
- EARTH IN SECTION
- GRAVEL IN SECTION
- CONCRETE
- ALUMINUM CHECKERPLATE
- 2 SACK SLURRY
- 2 SACK SLURRY
- 2 SACK SLURRY

VALVES

- BALL VALVE
- BUTTERFLY VALVE
- SILENT CHECK VALVE
- GATE VALVE
- PLUG VALVE
- SWING CHECK VALVE
- STRAINER
- PRESSURE REDUCING/SUSTAINING VALVE (ELEVATION VIEW)
- MAGNETIC FLOW METER
- PRESSURE REDUCING/SUSTAINING VALVE (PLAN VIEW)

MECHANICAL PIPE AND FITTING SYMBOLS

- | DOUBLE LINE* | SINGLE LINE | DOUBLE LINE* | SINGLE LINE |
|--------------|-------------|--------------|-------------|
| | | | |
| | | | |
| | | | |
| | | | |
| | | | |
| | | | |
| | | | |
| | | | |
| | | | |
| | | | |
| | | | |
| | | | |
| | | | |
| | | | |
| | | | |

SYMBOLS:

- CLEANOUT
- FIRE HYDRANT
- SIAMESE FIRE DEPARTMENT CONNECTION
- WASHDOWN FIRE HYDRANT
- FREE STANDING FIRE HYDRANT
- FLOOR DRAIN
- CATCH BASIN
- WELL SYMBOL
- FLOW ARROW
- PIPE CROSSING
- WATER SURFACE LEVEL
- AIR VAC
- BLOWOFF
- SOLENOID
- FLOW SWITCH
- AIR FILTER
- SUBMERSIBLE PUMP
- PUMP
- HOSE RACK
- SLIDE GATE
- AERATOR

DRAFT - NOT FOR CONSTRUCTION

W:\3.0 Clients\Heritage Ranch Community Services District\1029\10090 WRF Upgrade Design\6.0 Working Files\0-CAD\1-SHEET FILES\G-HRCSO-WWTP - Gen.dwg 11/10/2023 2:14 PM Lauren Cetin

REV	DATE	BY	DESCRIPTION

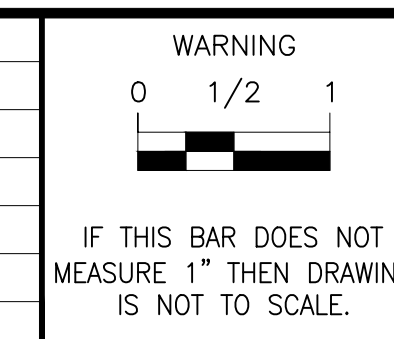

DESIGNED	EKW
DRAWN	PMD
CHECKED	MNR
SCALE	NO SCALE

PREPARED BY: MATTHEW N. RODRIGUES
 DATE: _____
 RCE No.: 84311

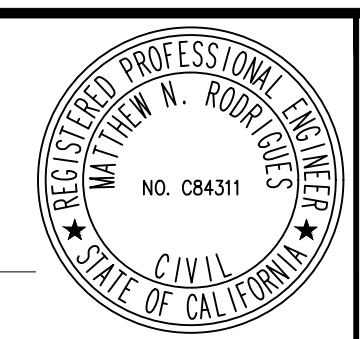

805 AEROVISTA PLACE, SUITE 201
 PHONE: (805) 457-8833

SAN LUIS OBISPO, CA 93401
 FAX: (805) 888-2764

HERITAGE RANCH COMMUNITY SERVICES DISTRICT
 4870 HERITAGE ROAD
 PASO ROBLES, CA 93446

APPROVED: _____
 POSITION: _____ DATE: _____

WATER RESOURCE RECOVERY FACILITY UPGRADE
 GENERAL

LEGENDS AND SYMBOLS

DRAWING
G-003
 SHEET X OF X
 PROJECT # _____

ABBREVIATIONS

AA	AVERAGE ANNUAL	E	ELECTRICAL, EAST, EXISTING	L	LENGTH, LINE	S	SEWER, SOUTH
ABAND	ABANDONED	EA	EACH	LAB	LABORATORY	SCADA	SUPERVISORY CONTROL AND DATA ACQUISITION
AB, A.B.	AGGREGATE BASE, ANCHOR BOLT	EC	END OF CURVE	LBS	POUNDS	SCH/SCHED	SCHEDULE
AC, A.C.	ASPHALT CONCRETE	EF	EACH FACE	LG	LONG	SCR	SCREENINGS
ACP	ASBESTOS CEMENT PIPE	EG	EXISTING GRADE	LL	LIVE LOAD	SD	STORM DRAIN
ADDIT.	ADDITIONAL	EI&C	ELECTRICAL, INSTRUMENTATION, AND CONTROL	LLDPE	LINEAR LOW-DENSITY POLYETHYLENE	SDMH	STORM DRAIN MANHOLE
ADJ.	ADJUSTABLE	EL., ELEV	ELEVATION	LOG	LIP OF GUTTER	SDR	STANDARD DIMENSION RATIO
ADWF	AVERAGE DRY WEATHER FLOW	ELL	ELBOW	LR	LONG RADIUS	SECT	SECTION
AGG	AGGREGATE	ELEC(T)	ELECTRIC(AL)	LPA	LOW PRESSURE AIR	SF	SQUARE FOOT
ALUM	ALUMINUM	EMG	EMERGENCY	LT	LEFT TURN	SG	SLIDE GATE, STOP GATE, SLUICE GATE
APCD	SAN LUIS OBISPO COUNTY AIR POLLUTION CONTROL DISTRICT	EOR	ENGINEER OF RECORD			SH	SODIUM HYPOCHLORITE
		EPB	ELECTRICAL PULL BOX	MAX	MAXIMUM	SHT	SHEET
APPRO.	APPROXIMATELY	EQ	EQUALIZATION	MCC	MOTOR CONTROL CENTER	SIM	SIMILAR
ARCH	ARCHITECTURAL	EQUIP	EQUIPMENT	MCIP	MEMBRANE CLEAN-IN-PLACE	SL	SLUDGE
ASPH	ASPHALT	ETS	ELECTROLYSIS TEST STATION	MD	MAXIMUM DAY	SOR	STRUCTURAL ENGINEER OR RECORD
AVG	AVERAGE	EXH	EXHAUST	MECH	MECHANICAL	SPEC	SPECIFICATION(S)
ARV	AIR RELEASE VALVE	EXIST, (E)	EXISTING	MBR	MEMBRANE BIOREACTOR	SQ	SQUARE
AR	AIR RELEASE	EXP	EXPANSION	MET	METAL	SS, STN STL	STAINLESS STEEL
ASSY	ASSEMBLY	EW	EACH WAY	MFR, MNFR	MANUFACTURER	STA	STATION
AVRV	AIR/VACUUM RELIEF VALVE	(F)	FUTURE	MJ	MECHANICAL JOINT	STD	STANDARD
AWWF	AVERAGE WET WEATHER FLOW	FA	FOUL AIR	MG	MILLION GALLON	ST(L)	STEEL
BC	BEGINNING OF CURVE	FAC	FACTORY	MGD	MILLION GALLONS PER DAY	STR(UCT)	STRUCTUR(E), (AL)
BD	BACKDRAIN	FB	FABRICATED	MH	MANHOLE	SV	SOLENOID VALVE
B.D.	SAN LUIS OBISPO COUNTY BUILDING DEPARTMENT	FC	FLEXIBLE COUPLING	MIN	MINIMUM	SW	SOLENT WELD
BF	BLIND FLANGE	FCA	FLANGE COUPLING ADAPTER	MISC	MISCELLANEOUS	SWD	SIDE WATER DEPTH
BFD	BUTTERFLY DAMPER	FCO	FLOOR CLEANOUT	MM	MAXIMUM MONTH	SYS	SYSTEM
BFV	BUTTERFLY VALVE	FD	FLOOR DRAIN	MNTD	MOUNTED		
BGS	BELOW GROUND SURFACE	FE	FLOOR EFFLUENT	MPH	MILES PER HOUR		
BLDG	BUILDING	FX	FIRE EXTINGUISHER	MW	MAXIMUM WEEK		
BM	BEAM, BENCH MARK	FES	FLARED END SECTION			T	TELEPHONE
BO	BLOWOFF	FF	FINISH FLOOR	N	NORTH	T/	TOP
BOC	BACK OF CURB	FG	FINISH GRADE	(N)	NEW	TBM	TEMPORARY BENCHMARK
BOT, BOTT	BOTTOM	FH	FINISH GRADE	N.F.C.	NOT FOR CONSTRUCTION	T&B	TOP AND BOTTOM
B&S	BELL AND SPIGOT	FIN	FINISH GRADE	NA	NOT APPLICABLE	T/C, TOC, TC	TOP OF CONCRETE
BV	BALL VALVE	FL	FLOW LINE	NGVD	NATIONAL GEODETIC VERTICAL DATUM	TD	TOP OF DIKE
		FLR	FLOOR	NIC	NOT IN CONTRACT	TDH	TOTAL DYNAMIC HEAD
C	CURVE	FLG	FLANGE	NO.	NUMBER	TEMP	TEMPERATURE
CA	CITRIC ACID	FLEX	FLEXIBLE	NPT	NATIONAL PIPE THREAD	TG	TOP OF GRATE
CALTRANS	CALIFORNIA DEPARTMENT OF TRANSPORTATION	FOC	FACE OF CONCRETE	NTS	NOT TO SCALE	TH	THICKNESS
CATV	CABLE TV	FRP	FIBERGLASS REINFORCED PLASTIC			THD	THREADED
CATVR	CABLE TV RISER	FS	FINISH SURFACE	OAD	OVERALL DEPTH	TOP	TOP OF PAVEMENT
CB	CATCH BASIN	FSN	FUSION	OC	ON CENTER	TRW	TOP OF RINGWALL
CC, C/C	CENTER TO CENTER	FT	FOOT	OCU	ODOR CONTROL UNIT	TW	TOP OF WALL
CF	CUBIC FEET	FTG	FOOTING	OD	OUTSIDE DIAMETER	TP	TEST PIT
CFM	CUBIC FEET PER MINUTE			OF	OVERFLOW	T/S, TOS	TOP OF STEEL
CI	CAST IRON	G	GAS	OG	ORIGINAL GROUND	TYP	TYPICAL
CISP	CAST IRON SOIL PIPE	GAL	GALLON	OPNG(S)	OPENING(S)	T--P	TYPE _____PIPE
CL, C	CENTERLINE	GA	GAUGE	OH	OVERHEAD	T--S	TYPE _____SUPPORT
CLSM	CONTROLLED LOW STRENGTH MATERIAL	GALV	GALVANIZED	P	PNEUMATIC, PIPE		
CLR	CLEAR(ANCE)	GB	GRADE BREAK	PACP	PERFORATED ASBESTOS CEMENT PIPE	UD	UNDERDRAIN
CMPR	COMPRESSION	GI	GALVANIZED IRON	PCCP	PRETENSIONED CONCRETE CYLINDER PIPE	UV	ULTRAVIOLET
CO	CLEANOUT	GPD	GALLONS PER DAY	PC	POINT OF CURVE (BEGIN CURVE)		
COL	COLUMN	GPFSD	GALLONS PER SQUARE-FOOT DAY	PD	PROCESS DRAIN (GRAVITY)	V, VERT	VERTICAL
CONC	CONCRETE	GPH	GALLONS PER HOUR	PDF	PROCESS DRAIN (FORCE MAIN)	VFD	VARIABLE FREQUENCY DRIVE
CONN	CONNECTION	GPM	GALLONS PER MINUTE	PEX	CROSSLINKED POLYETHYLENE TUBE	VTR	VENT TO ROOF
CONST	CONSTRUCTION	GS	GALVANIZED STEEL	PG	PRESSURE GAUGE		
CONT	CONTINU(ED), (OUS)	GSP	GALVANIZED STEEL PIPE	PH	PEAK HOUR	W	WATER, WELDED, WEST
CP	CONTROL POINT, CATHODIC PROTECTION	GV	GATE VALVE	PI	POINT OF INTERSECTION	WAS	WASTE ACTIVATED SLUDGE
CPLG	COUPLING	H, HT	HEIGHT	PL	PLATE	WB	WATER BAR
CRA	CHLORINE RESIDUAL ANALYZER	HB	HOSE BIB	P/L	PROPERTY LINE	W/	WITH
CS	SODIUM HYDROXIDE (CAUSTIC SODA)	HG	HOT DIP GALVANIZED	PRES(S)	PRESSURE	WC	WATER CLOSET
CTS	CATHODIC TEST STATION	HDPE	HIGH DENSITY POLYETHYLENE	PRM	PERMEATE	WCO	WALL CLEANOUT
CU	COPPER	HM	HOLLOW METAL	PRV	PRESSURE RELEASE VALVE, PRESSURE REDUCING VALVE	WG	WEIR GATE
		HORIZ.	HORIZONTAL			WH	WATER HEATER
D	DRAIN	H.P.	HIGH POINT, HINGE POINT	PS	PUMP STATION	WL	WATERLINE
DEFL	DEFLECTION	HP	HORSEPOWER	PSF	POUNDS PER SQUARE FOOT	WLD	WELDED
DEG	DEGREE	HPI	HORIZONTAL POINT OF INFLECTION	PSI	POUNDS PER SQUARE INCH	WMH	WATER MANHOLE
DEPT	DEPARTMENT	HR	HOUR	PT	POINT OF TANGENT (END CURVE)	W/O	WITHOUT
DI	DROP INLET	HWL	HIGH WATER LEVEL	PVC	POLYVINYL CHLORIDE	WTR	WATER
DIA, Ø	DIAMETER			PW	POTABLE WATER	WV	WATER VALVE
DIM	DIMENSION			Q	FLOW	WS	WATER SURFACE
DIP	DUCTILE IRON PIPE			R	RADIUS	WW	WASTEWATER
DISCH	DISCHARGE	IA	INSTRUMENT AIR	RAS	RETURN ACTIVATED SLUDGE	WWF	WASTEWATER (FORCEMAIN)
DL	DEADLOAD	ID	INSIDE DIAMETER	RCP	REINFORCED CONCRETE PIPE	YD	YARD
DMJ	DOUBLE MECHANICAL JOINT	IE	INVERT ELEVATION	RCCP	REINFORCED CONCRETE CYLINDER PIPE		
DN	DOWN	IN	INCHES	REINF	REINFORCE(D), (MENT)	#	POUND, NUMBER
DR	DIMENSION RATIO	INF	INFLUENT	REQ'D	REQUIRED	&	AND
DWG(S)	DRAWING(S)	INSUL	INSULATION	RESIL	RESILIENT	⊙	AT
		INV	INVERT	RESV	RESERVOIR	∅	NOMINAL DIAMETER
		IPS	IRON PIPE SIZE	RM	ROOM		
		IRR	IRRIGATION	RSP	ROCK SLOPE PROTECTION		
				RT	RIGHT TURN		
		JB	JUNCTION BOX	R/W, ROW	RIGHT OF WAY		
		JT	JOINT	RW	RECYCLED WATER		

DRAFT - NOT FOR CONSTRUCTION

W:\3.0 Clients\Heritage Ranch Community Services District 1029\10090 WRF Upgrade Design\6.0 Working Files\0-CAD\1-SHEET FILES\G-HRCSO-WWTP - Gen.dwg 11/10/2023 2:14 PM Lauren Cetin

	<p>WARNING</p> <p>IF THIS BAR DOES NOT MEASURE 1" THEN DRAWING IS NOT TO SCALE.</p>	<p>DESIGNED <u> EKW </u></p> <p>DRAWN <u> PMD </u></p> <p>CHECKED <u> MNR </u></p> <p>SCALE <u> NO SCALE </u></p>	<p>PREPARED BY:</p> <div style="text-align: center;"> </div> <p>MATTHEW N. RODRIGUES DATE _____</p> <p>RCE No.: 84311</p>	<p>405 AEROVISTA PLACE, SUITE 201 SAN LUIS OBISPO, CA 93401</p> <p>PHONE: (805) 457-8833 FAX: (805) 888-2764</p>	<p>HERITAGE RANCH COMMUNITY SERVICES DISTRICT</p> <p>4870 HERITAGE ROAD</p> <p>PASO ROBLES, CA 93446</p> <p>APPROVED: _____</p> <p>_____ POSITION DATE _____</p>	<p>WATER RESOURCE RECOVERY FACILITY UPGRADE</p> <p>GENERAL</p> <p style="font-size: 24pt; font-weight: bold;">G-004</p> <p>SHEET X OF X</p> <p>PROJECT # _____</p>
--	---	---	--	--	---	--

ABBREVIATIONS

W:\3.0 Clients\Heritage Ranch Community Services District\1029\10090 WRF Upgrade Design\6.0 Working Files\CAD\1-SHEET FILES\G-HRCSO-WWTP - Gen.dwg 11/10/2023 2:14 PM Lauren Cetin

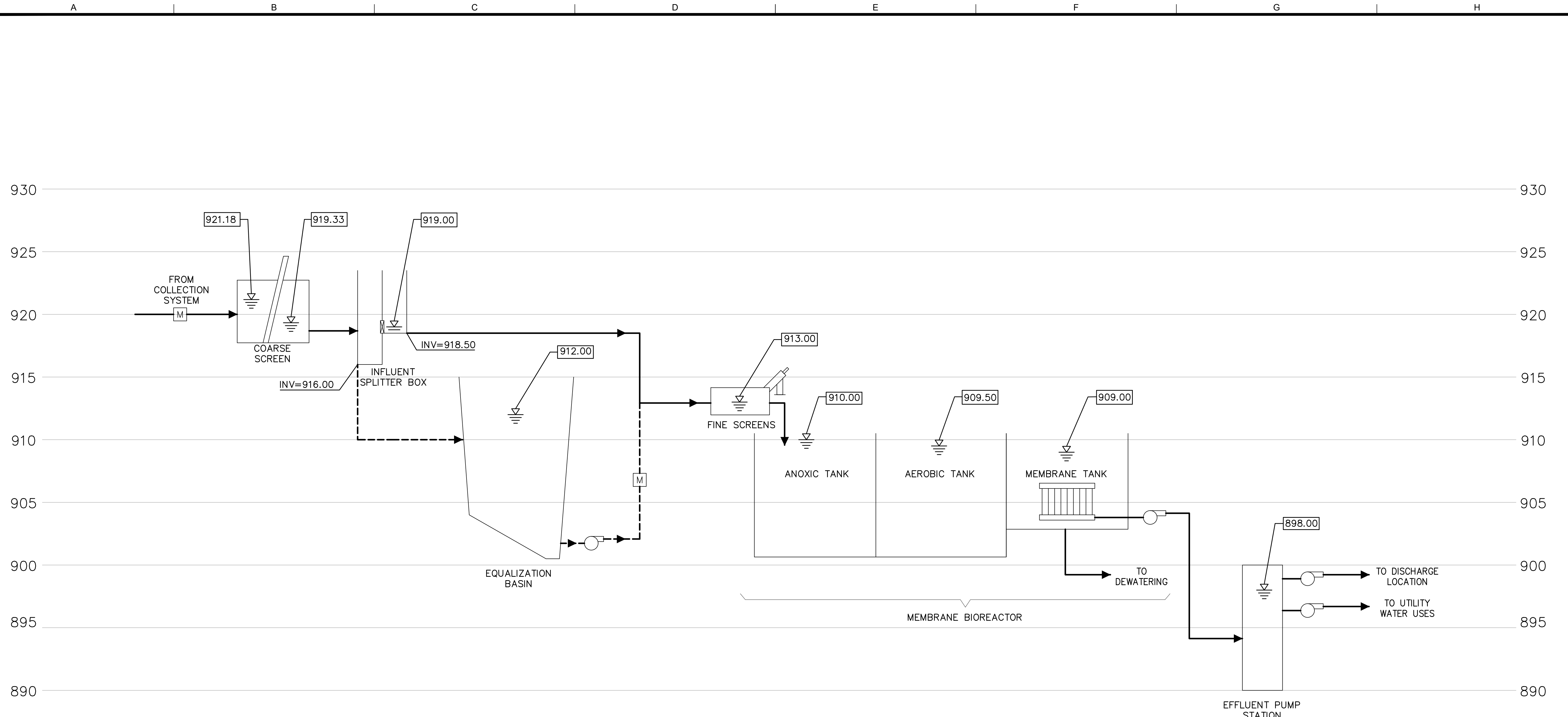

LEGEND:

AA = 0.24 MGD

AA WS EL (FT)

————— PROCESS FLOW

----- EQUALIZED FLOW

DRAFT - NOT FOR CONSTRUCTION

<p>WARNING</p> <p>0 1/2 1</p> <p>IF THIS BAR DOES NOT MEASURE 1" THEN DRAWING IS NOT TO SCALE.</p>				<p>DESIGNED: MNR</p> <p>DRAWN: PMD</p> <p>CHECKED: DSW</p> <p>SCALE: NO SCALE</p>	<p>PREPARED BY:</p> <p>MATTHEW N. RODRIGUES</p> <p>RCE No.: 84311</p>		<p>805 AEROVISTA PLACE, SUITE 201 PHONE: (805) 457-8833</p> <p>SAN LUIS OBISPO, CA 93401 FAX: (805) 888-2764</p>	<p>HERITAGE RANCH COMMUNITY SERVICES DISTRICT</p> <p>4870 HERITAGE ROAD</p> <p>PASO ROBLES, CA 93446</p>	<p>WATER RESOURCE RECOVERY FACILITY UPGRADE</p> <p>GENERAL</p> <p>HYDRAULIC PROFILE</p>	<p>DRAWING</p> <p>G-601</p> <p>SHEET X OF X</p> <p>PROJECT #</p>
REV	DATE	BY	DESCRIPTION	<p>APPROVED: _____ POSITION _____ DATE _____</p>						

W:\3.0 Clients\Heritage Ranch Community Services District\1029\10090 WRF Upgrade Design\6.0 Working Files\0-CAD\1-SHEET FILES\G-HRCSO-WWTP - Gen.dwg 11/10/2023 2:14 PM Lauren Cetin

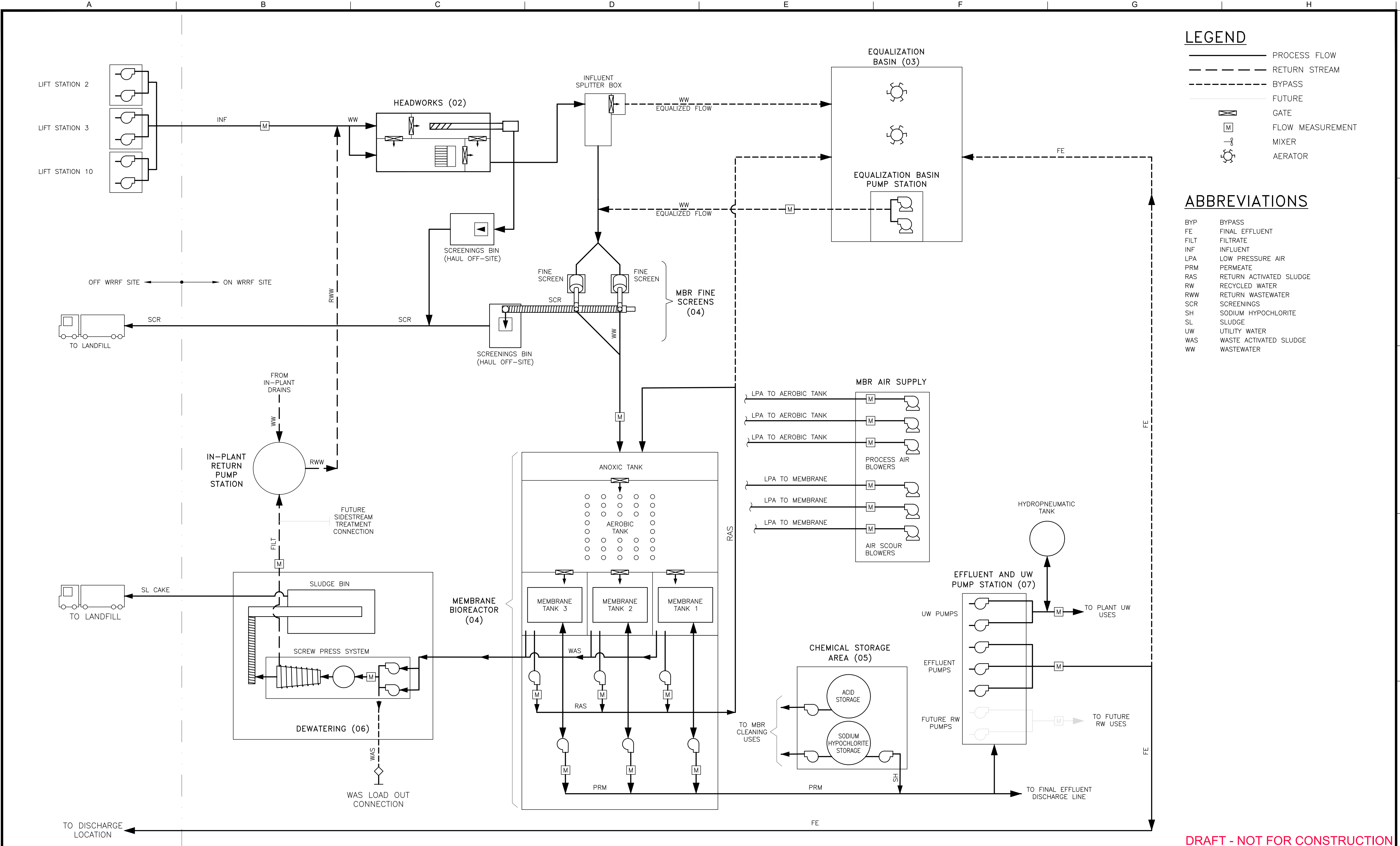

- ### LEGEND
- PROCESS FLOW
 - - - RETURN STREAM
 - - - BYPASS
 - - - FUTURE
 - ⊘ GATE
 - M FLOW MEASUREMENT
 - ⊕ MIXER
 - ⊙ AERATOR

- ### ABBREVIATIONS
- BYP BYPASS
 - FE FINAL EFFLUENT
 - FILT FILTRATE
 - INF INFLUENT
 - LPA LOW PRESSURE AIR
 - PRM PERMEATE
 - RAS RETURN ACTIVATED SLUDGE
 - RW RECYCLED WATER
 - RWW RETURN WASTEWATER
 - SCR SCREENINGS
 - SH SODIUM HYPOCHLORITE
 - SL SLUDGE
 - UW UTILITY WATER
 - WAS WASTE ACTIVATED SLUDGE
 - WW WASTEWATER

DRAFT - NOT FOR CONSTRUCTION

	<p>WARNING</p> <p>0 1/2 1</p> <p>IF THIS BAR DOES NOT MEASURE 1" THEN DRAWING IS NOT TO SCALE.</p>	<p>DESIGNED: <u>EKW</u></p> <p>DRAWN: <u>PMD</u></p> <p>CHECKED: <u>MNR</u></p> <p>SCALE: <u>NO SCALE</u></p>	<p>PREPARED BY:</p> <p>MATTHEW N. RODRIGUES RCE No.: 84311</p> <p>DATE: _____</p>		<p>805 AEROVISTA PLACE, SUITE 201 PHONE: (805) 457-8833</p> <p>SAN LUIS OBISPO, CA 93401 FAX: (805) 888-2764</p>	<p>HERITAGE RANCH COMMUNITY SERVICES DISTRICT 4870 HERITAGE ROAD PASO ROBLES, CA 93446</p> <p>APPROVED: _____ POSITION: _____ DATE: _____</p>	<p>WATER RESOURCE RECOVERY FACILITY UPGRADE</p> <p>GENERAL</p> <p>PROCESS FLOW DIAGRAM</p>	<p>DRAWING</p> <p>G-602</p> <p>SHEET X OF X PROJECT # _____</p>
--	---	---	---	--	--	---	---	--

\\EgnyteDrive W Drive\3.0 Clients\Heritage Ranch Community Services District 1029\10090 WRF Upgrade Design\6.0 Working Files\0-CAD\1-SHEET FILES\C-HRCSO-WWTP - Site.dwg 11/10/2023 4:20 PM Chris Durbin

GENERAL NOTES

- NO CONSTRUCTION SHALL BE STARTED WITHOUT PLANS APPROVED BY [ENTITY]. [ENTITY] SHALL BE NOTIFIED AT LEAST 24 HOURS PRIOR TO STARTING OF CONSTRUCTION AND OF THE TIME LOCATION OF THE PRECONSTRUCTION CONFERENCE.
- FOR ANY CONSTRUCTION PERFORMED THAT IS NOT IN COMPLIANCE WITH PLANS OR PERMITS APPROVED FOR THE PROJECT THE [ENTITY] MAY REVOKE ALL ACTIVE PERMITS AND RECOMMEND THAT COUNTY CODE ENFORCEMENT PROVIDE A WRITTEN NOTICE OR STOP WORK ORDER IN ACCORDANCE WITH SECTION 22.52.140 [23.10] OF THE LAND USE ORDINANCE.
- THE CONTRACTOR SHALL BE RESPONSIBLE FOR MAINTAINING ALL WEATHER ACCESS AT ALL TIMES TO EXISTING PROPERTIES LOCATED IN THE VICINITY OF WORK. ADDITIONALLY, THEY SHALL BE RESPONSIBLE FOR MAINTAINING ALL EXISTING SERVICES, INCLUDING UTILITY, GARBAGE COLLECTION, MAIL DISTRIBUTION, ETC., TO ALL EXISTING PROPERTIES LOCATED IN THE VICINITY OF WORK.
- ON-SITE HAZARDS TO PUBLIC SAFETY SHALL BE SHIELDED BY CONSTRUCTION FENCING. FENCING SHALL BE MAINTAINED BY THE CONTRACTOR UNTIL SUCH TIME THAT THE PROJECT IS COMPLETED AND OCCUPIED, POTENTIAL HAZARDS HAVE BEEN MITIGATED, OR ALTERNATIVE PROTECTIVE MEASURES HAVE BEEN INSTALLED.
- SOILS TESTS SHALL BE DONE IN ACCORDANCE WITH THE SPECIFICATIONS. ALL TESTS MUST BE MADE WITHIN 15 DAYS PRIOR TO THE PLACING MATERIAL. THE TEST RESULTS SHALL CLEARLY INDICATE THE LOCATION AND SOURCE OF THE MATERIAL.
- ROADWAY COMPACTION TESTS SHALL BE MADE ON SUBGRADE MATERIAL, AGGREGATE BASE MATERIAL, AND MATERIAL AS SPECIFIED BY THE SOILS ENGINEER. SAID TESTS SHALL BE MADE PRIOR TO THE PLACEMENT OF THE NEXT MATERIAL LIFT.
- SUBGRADE MATERIAL SHALL BE COMPACTED TO A RELATIVE COMPACTION OF 95% IN THE ZONE BETWEEN FINISHED SUBGRADE ELEVATION AND A MINIMUM OF 1-FOOT BELOW. ALL MATERIAL IN FILL SECTIONS BELOW THE ZONE MENTIONED ABOVE SHALL BE COMPACTED TO 90% RELATIVE COMPACTION.
- A REGISTERED CIVIL ENGINEER SHALL CERTIFY THAT THE IMPROVEMENTS WHEN COMPLETED ARE IN ACCORDANCE WITH THE PLANS PRIOR TO THE REQUEST FOR A FINAL INSPECTION. RECORD DRAWINGS SHALL BE PREPARED AFTER CONSTRUCTION IS COMPLETED. THE CIVIL ENGINEER CERTIFYING THE IMPROVEMENTS AND PREPARING AS-BUILT PLANS MAY BE PRESENT WHEN THE FINAL INSPECTION IS MADE BY THE COUNTY.
- ALL UTILITY COMPANIES SHALL BE NOTIFIED PRIOR TO THE START OF CONSTRUCTION.
- A COUNTY ENCROACHMENT PERMIT IS REQUIRED FOR ALL WORK DONE WITHIN THE COUNTY RIGHT-OF-WAY. THE ENCROACHMENT PERMIT MAY ESTABLISH ADDITIONAL CONSTRUCTION, UTILITY AND TRAFFIC CONTROL REQUIREMENTS.
- THE COUNTY INSPECTOR ACTING ON BEHALF OF [ENTITY] MAY REQUIRE REVISIONS IN THE PLANS TO SOLVE UNFORESEEN PROBLEMS THAT MAY ARISE IN THE FIELD. ALL REVISIONS SHALL BE SUBJECT TO THE APPROVAL OF THE ENGINEER OF WORK.
- THE STRUCTURAL SECTION SHALL BE BASED ON SOILS TESTS TAKEN AT THE TIME OF CONSTRUCTION AND USING A TRAFFIC INDEX OF 8 FOR THE EXTERIOR ACCESS ROAD AND A TRAFFIC INDEX OF 6 FOR THE INTERIOR OF THE SITE.
- HYDRO-SEEDING OR OTHER PERMANENT EROSION CONTROL SHALL BE PLACED AND ESTABLISHED WITH 90% COVERAGE ON ALL DISTURBED SURFACES (OTHER THAN PAVED OR GRAVEL SURFACES) PRIOR TO THE FINAL INSPECTION.
- ENGINEER OF RECORD TO PROVIDE A FINAL REPORT STATING THE WORK PERFORMED IS IN SUBSTANTIAL CONFORMANCE WITH THE APPROVED PLANS INCLUDING SPECIAL INSPECTION REPORTS.

UNDERGROUND FACILITIES

- ENGINEER HAS SEARCHED AVAILABLE KNOWN RECORDS FOR INFORMATION ABOUT UNDERGROUND FACILITIES INCLUDING FACILITIES PRESENTLY BEING DESIGNED IN THE VICINITY OF THE PROJECT. TO THE BEST OF THE ENGINEER'S ABILITY THOSE UNDERGROUND FACILITIES WHICH MAY AFFECT THE WORK ARE SHOWN ON THESE DRAWINGS. LOCATIONS AND ELEVATIONS OF EXISTING UTILITIES SHOWN ON THESE DRAWINGS ARE BASED ON FACILITY DESIGN DRAWINGS AND ARE APPROXIMATE ONLY. CONTRACTOR IS RESPONSIBLE FOR VERIFYING THE PRESENCE AND LOCATION OF ALL EXISTING FACILITIES.
- AT LEAST 48 HOURS BEFORE COMMENCING ANY EXCAVATION, CONTRACTOR SHALL REQUEST UNDERGROUND SERVICE ALERT AND NON-MEMBER COMPANIES OR UTILITIES TO MARK OR OTHERWISE INDICATE THE LOCATION(S) OF THEIR SUBSURFACE FACILITIES. CONTRACTOR SHALL MARK THE PROPOSED AREA OF EXCAVATION IN ACCORDANCE WITH THE DIGALERT DELINEATION GUIDE.
- PRIOR TO PIPELINE EXCAVATION, CONTRACTOR SHALL EXCAVATE AND EXPOSE EXISTING FACILITIES (POTHOLE) IN LOCATIONS WHERE NEW FACILITIES ARE PROPOSED TO ESTABLISH THE EXACT LOCATION, SIZE, AND DEPTH, AND DETERMINE IF THERE WILL BE AN INTERFERENCE WITH PROPOSED FACILITIES. CHANGES OR DELAYS CAUSED BY CONTRACTOR'S FAILURE TO PERFORM "POTHOLING" AND INTERFERENCE LOCATION WORK SHALL NOT BE ELIGIBLE FOR EXTRA WORK COMPENSATION OR TIME EXTENSION. UPON LEARNING OF THE EXISTENCE OR LOCATION OF ANY UNDERGROUND FACILITY OMITTED OR SHOWN INCORRECTLY ON THESE DRAWINGS, OR IMPROPERLY MARKED OR OTHERWISE INDICATED, CONTRACTOR SHALL IMMEDIATELY NOTIFY OWNER, PROVIDING FULL DETAILS AS DEPTH, LOCATION, SIZE, AND FUNCTION.
- CONTRACTOR SHALL PRESERVE ALL SURVEY MARKERS AND MONUMENTATION IN PLACE. IF ANY EXISTING MONUMENTS REQUIRE REMOVAL TO PERFORM THE WORK, CONTRACTOR SHALL NOTIFY OWNER AT LEAST 7 DAYS IN ADVANCE OF CONSTRUCTION. SAID MONUMENTS WILL BE TIED OUT AND RE-ESTABLISHED BY OWNER.
- CONTRACTOR SHALL PRESERVE ALL PIPELINE MARKINGS. WATER MARKINGS DESTROYED WILL BE REPLACED AT THE CONTRACTOR'S EXPENSE.

GENERAL CONSTRUCTION

- ALL SPECIFICATIONS, DRAWINGS, AND DETAILS INCLUDED IN THE CONTRACT DOCUMENTS SHALL FULLY APPLY TO THE WORK WHETHER OR NOT SPECIFICALLY REFERENCED.
- NORMAL WORKING HOURS ARE 7:00 AM TO 4:00 PM MONDAY THROUGH FRIDAY. NORMAL INSPECTION HOURS ARE 7:00 AM TO 4:00 PM, MONDAY THROUGH FRIDAY, EXCEPT HOLIDAYS. CONSTRUCTION WILL NOT TAKE PLACE ON WEEKENDS OR HOLIDAYS UNLESS SPECIFICALLY APPROVED BY OWNER.
- THE CONTRACTOR AGREES THAT HE SHALL ASSUME SOLE AND COMPLETE RESPONSIBILITY FOR THE JOB SITE CONDITIONS DURING THE COURSE OF CONSTRUCTION OF THIS PROJECT, INCLUDING SAFETY OF ALL PERSONS AND PROPERTY; THAT THIS REQUIREMENT SHALL APPLY CONTINUALLY AND NOT BE LIMITED TO NORMAL WORKING HOURS; AND THAT THE CONTRACTOR SHALL HOLD OWNER AND THE ENGINEER HARMLESS FROM ANY AND ALL LIABILITY, REAL OR ALLEGED, IN CONNECTION WITH THE PERFORMANCE OF WORK ON THIS PROJECT.
- STATIONING AND DISTANCES SHOWN ON THE DRAWINGS ARE BASED ON HORIZONTAL MEASUREMENTS PROJECTED FROM THE PIPE CENTERLINE UNLESS NOTED OTHERWISE.
- DIMENSIONED DISTANCES SHALL GOVERN OVER SCALED DISTANCES.
- MAINTAIN ON-SITE THE LATEST SIGNED CONSTRUCTION DRAWINGS AT ALL TIMES. MAINTAIN A COMPLETE AND ACCURATE RECORD OF ALL CHANGES IN CONSTRUCTION FROM THAT SHOWN ON THE PLANS AND SPECIFICATIONS FOR THE PURPOSE OF PROVIDING A BASIS FOR RECORD DRAWINGS. NO CHANGES SHALL BE MADE WITHOUT PRIOR WRITTEN APPROVAL FROM ENGINEER.
- CONTRACTOR SHALL VIDEO TAPE AND DOCUMENT THE PRE-EXISTING CONDITIONS OF THE JOBSITE AND PROPERTIES ADJACENT TO THE PROJECT, AND SUBMIT THE VIDEO ON DVD TO OWNER PRIOR TO THE START OF CONSTRUCTION. CONTRACTOR SHALL PROTECT EXISTING JOBSITE CONDITIONS AND ADJACENT PROPERTIES DURING THE WORK AND REPAIR DAMAGE TO LANDSCAPING, PAVING, IRRIGATION, STRUCTURES, ETC., CAUSED BY THE WORK.
- IN ACCORDANCE WITH CALIFORNIA HEALTH AND SAFETY CODE SECTION 7050.5, THE CONTRACTOR SHALL NOTIFY [ENTITY] IF HUMAN REMAINS ARE DISCOVERED DURING THE COURSE OF THE WORK. THE CONTRACTOR SHALL NOTIFY [ENTITY(S)] IF HUMAN REMAINS OR ARCHAEOLOGICAL MATERIALS ARE ENCOUNTERED.
- CONTRACTOR, SUBCONTRACTORS, AND SUPPLIERS PERFORMING WORK OR SUPPLYING EQUIPMENT AND MATERIALS SHALL REVIEW ALL DRAWINGS AND SPECIFICATIONS.
- DURING CONSTRUCTION, IN THE EVENT ARCHAEOLOGICAL RESOURCES ARE UNEARTHED OR DISCOVERED DURING ANY CONSTRUCTION ACTIVITIES, CONSTRUCTION ACTIVITIES SHALL CEASE AND A QUALIFIED ARCHAEOLOGIST WILL BE CONTACTED.
- WATER TRUCKS OR SPRINKLER SYSTEMS SHALL BE USED IN SUFFICIENT QUANTITIES TO PREVENT AIRBORNE DUST FROM LEAVING THE SITE AND EXCEEDING THE APCD'S LIMIT OF 20% OPACITY FOR GREATER THAN 3 MINUTES IN ANY 60-MINUTE PERIOD. INCREASED WATERING FREQUENCY IS REQUIRED WHEN WINDS EXCEED 15 MPH. CONTRACTOR SHALL IMPLEMENT ALL DUST CONTROL MEASURES IDENTIFIED IN MITIGATION MEASURE AQ-1.
- THE CONTRACTOR SHALL DESIGNATE A PERSON OR PERSONS TO MONITOR THE FUGITIVE DUST EMISSIONS AND ENHANCE IMPLEMENTATION OF DUST CONTROL MEASURES AS NECESSARY TO MINIMIZE DUST COMPLAINTS, REDUCE VISIBLE EMISSIONS BELOW THE APCD'S LIMIT OF 20% OPACITY FOR GREATER THAN 3 MINUTES IN ANY 60 MINUTE PERIOD. THE NAME AND TELEPHONE NUMBER OF SUCH PERSONS SHALL BE PROVIDED TO THE APCD ENGINEERING AND COMPLIANCE DIVISION PRIOR TO START OF ANY GRADING, EARTHWORK, OR DEMOLITION.
- ALL WORK SHALL COMPLY WITH THE CONDITIONS OF APPROVAL AND THE PROJECT'S MITIGATION AND MONITORING PROGRAM IDENTIFIED IN SPECIFICATION SECTION 013543 ENVIRONMENTAL REQUIREMENTS.
- PRIOR TO ANY SITE DISTURBANCE, A LICENSED SURVEYOR FURNISHED BY CONTRACTOR SHALL STAKE THE BUILDING CORNERS, ESTABLISH AVERAGE NATURAL GRADE, AND SET A BENCHMARK.
- DURING CONSTRUCTION, IF A CALIFORNIA RED-LEGGED FROG IN ANY LIFE STAGE IS DISCOVERED IN THE WORK AREA AS PART OF MONITORING SURVEYS AND IS AT RISK FROM PROJECT-RELATED ACTIVITIES, WORK MUST BE SUSPENDED ON THAT PARTICULAR PHASE OF THE PROJECT UNTIL THE INDIVIDUAL VOLUNTARILY LEAVES THE AREA OR THE APPROVED BIOLOGIST IS AVAILABLE TO CAPTURE AND MOVE IT OUT OF HARM'S WAY.
- ANY EXCAVATION OR EQUIPMENT/MATERIALS STORAGE AREAS THAT COULD ENTRAP CALIFORNIA RED-LEGGED FROGS MUST BE COVERED EACH NIGHT AND DURING PERIODS OF TIME WHEN ACTIVE CONSTRUCTION IS NOT OCCURRING AND CHECKED PRIOR TO USE BEFORE THE START OF ANY WORK DAY IN ORDER TO REDUCE THE CHANCE OF INJURY OR MORTALITY THAT COULD RESULT FROM CONFINING INDIVIDUALS IN THESE FEATURES.
- A PRE-CONSTRUCTION MEETING IS REQUIRED WITH THE INSPECTOR TO GO OVER THE SPECIAL INSPECTION REPORTING REQUIREMENTS, STORM WATER REQUIREMENTS, QSP, EROSION & SEDIMENTATION CONTROL, MITIGATION MEASURES, PROGRESS REPORTS AS DETERMINED AT THE PRE-CONSTRUCTION MEETING & REPORTS REQUIRED. CALL [PERSON, (000) 000-0000] TO COORDINATE WITH THE AREA INSPECTOR.

GRADING AND SITE WORK NOTES

- CONTRACTOR SHALL CONTROL ALL RUNOFF FROM CONSTRUCTION ACTIVITIES AND SHALL DEVELOP AND IMPLEMENT A SWPPP. CONTRACTOR SHALL BE RESPONSIBLE FOR THE PLACEMENT AND MAINTENANCE OF ALL BMPs PRIOR TO ANY CONSTRUCTION ACTIVITIES OCCURRING AND THROUGHOUT THE DURATION OF THE PROJECT. REFER TO SPECIFICATION SECTION 01 57 23.
- BORING LOGS PER THE GEOTECHNICAL REPORT PREPARED BY GEOSOLUTIONS TITLED ["TITLE"] AND PER THE GEOTECHNICAL REPORT PREPARED BY [ENTITY], INC. TITLED ["TITLE"] ARE INCLUDED IN THE SPECIFICATIONS.
- CONTRACTOR SHALL BE RESPONSIBLE TO FAMILIARIZE HIMSELF WITH THE SITE CONDITIONS AND THE EXTENT OF CLEARING REQUIRED TO PERFORM THE WORK. CLEARING SHALL BE PERFORMED, IN ACCORDANCE WITH SPECIFICATIONS.
- CONTRACTOR SHALL MINIMIZE CLEARING AND GRUBBING ACTIVITIES ONLY TO THE EXTENT REQUIRED TO PERFORM THE WORK. CONTRACTOR SHALL PROTECT ALL EXISTING TREES IN PLACE.
- ALL DEBRIS, BRUSH, AND RUBBISH WITHIN THE WORK AREA SHALL BE REMOVED AND DISPOSED OF DAILY, EXCEPT AS OTHERWISE REQUIRED. SAID MATERIALS SHALL BE LEGALLY DISPOSED OF IN AN APPROVED OFFSITE LOCATION. WHERE REMOVAL OF SUBSURFACE OBSTRUCTIONS IS NECESSARY, CAVITIES CREATED BY THE REMOVAL SHALL BE CLEARED OF ALL LOOSE DEBRIS AND SOIL AND SHAPED TO PROVIDE ACCESS FOR BACKFILLING AND COMPACTION EQUIPMENT.
- CONTRACTOR SHALL RESTORE DISTURBED EARTH UPON COMPLETION OF THE SITE WORK.
- EXISTING CONTOURS ARE AT ±1'. CONTRACTORS SHALL GRADE MATERIAL AS REQUIRED TO ACHIEVE SPECIFIED FINISH GRADES.
- A LICENSED PROFESSIONAL SURVEYOR, FURNISHED BY THE CONTRACTOR SHALL CERTIFY THE ROUGH PAD ELEVATIONS ARE PER THE APPROVED PLANS.
- ADDITIONAL INFORMATION REGARDING SITE DRAINAGE CAN BE FOUND IN THE DRAINAGE REPORT PREPARED BY WATER SYSTEMS CONSULTING, INC ON [DATE AND TITLE].
- GEOTECHNICAL ENGINEER SHALL BE PRESENT ON-SITE DURING SUBGRADE EXCAVATION AND DURING OTHER MAJOR EARTHWORK ACTIVITIES.

EROSION CONTROL NOTES

- EROSION CONTROL MEASURES FOR WIND, WATER, MATERIAL STOCKPILES, AND TRACKING SHALL BE IMPLEMENTED ON ALL PROJECTS AT ALL TIMES AND SHALL INCLUDE SOURCE CONTROL, INCLUDING PROTECTION OF STOCKPILES, PROTECTION OF SLOPES, PROTECTION OF ALL DISTURBED AREAS, PROTECTION OF ACCESSSES, AND PERIMETER CONTAINMENT MEASURES. EROSION CONTROL SHALL BE PLACED PRIOR TO THE COMMENCEMENT OF GRADING AND SITE DISTURBANCE ACTIVITIES UNLESS [ENTITY] DETERMINES TEMPORARY MEASURES TO BE UNNECESSARY BASED UPON LOCATION, SITE CHARACTERISTICS OR TIME OF YEAR. THE INTENT OF EROSION CONTROL MEASURES SHALL BE TO KEEP ALL GENERATED SEDIMENTS FROM ENTERING A SWALE, DRAINAGE WAY, WATERCOURSE, ATMOSPHERE, OR MIGRATE ONTO ADJACENT PROPERTIES OR ONTO THE PUBLIC RIGHT-OF-WAY.
- SITE INSPECTIONS AND APPROPRIATE MAINTENANCE OF ALL EROSION CONTROL MEASURES/DEVICES SHALL BE CONDUCTED AND DOCUMENTED AT ALL TIMES DURING CONSTRUCTION AND ESPECIALLY PRIOR TO, DURING, AND AFTER RAIN EVENTS.
- THE CONTRACTOR SHALL BE RESPONSIBLE FOR THE PLACEMENT AND MAINTENANCE OF ALL EROSION CONTROL MEASURES/DEVICES AS SPECIFIED BY THE APPROVED PLAN UNTIL SUCH TIME THAT THE PROJECT IS ACCEPTED AS COMPLETE BY [ENTITY] OR UNTIL RELEASED FROM THE CONDITIONS OF APPROVAL OF THEIR GENERAL PERMIT. EROSION CONTROL MEASURES/DEVICES MAY BE RELOCATED, DELETED OR ADDITIONAL MEASURES/DEVICES MAY BE REQUIRED DEPENDING ON THE ACTUAL CONDITIONS ENCOUNTERED DURING CONSTRUCTION. ADDITIONAL EROSION CONTROL MEASURES/DEVICES SHALL BE PLACED AT THE DISCRETION OF THE ENGINEER OF WORK, COUNTY INSPECTOR, SWPPP MONITOR, OR RWQCB INSPECTOR. GUIDELINES FOR DETERMINING APPROPRIATE EROSION CONTROL DEVICES SHALL BE INCLUDED IN THE PLANS WITH ADDITIONAL MEASURES/DEVICES NOTED.
- WET WEATHER EROSION CONTROL MEASURES/DEVICES SHALL BE AVAILABLE, INSTALLED, AND/OR APPLIED BETWEEN OCTOBER 15 AND APRIL 15 OR ANYTIME WHEN THE RAIN PROBABILITY EXCEEDS 30%.
- THE CONTRACTOR SHALL BE RESPONSIBLE TO REVIEW THE PROJECT SITE PRIOR TO OCTOBER 15 (RAINY SEASON) AND TO COORDINATE AN IMPLEMENTATION PLAN FOR WET WEATHER EROSION CONTROL DEVICES. A LOCALLY BASED STANDBY CREW FOR EMERGENCY WORK SHALL BE AVAILABLE AT ALL TIMES DURING THE RAINY SEASON (OCTOBER 15 THROUGH APRIL 15). NECESSARY MATERIALS SHALL BE AVAILABLE AND STOCK PILED AT CONVENIENT LOCATIONS TO FACILITATE RAPID CONSTRUCTION OR MAINTENANCE OF TEMPORARY DEVICES WHEN RAIN IS IMMINENT.
- IN THE EVENT OF A FAILURE, THE CONTRACTOR AND/OR HIS REPRESENTATIVE SHALL BE RESPONSIBLE FOR CLEANUP AND ALL ASSOCIATED COSTS OR DAMAGE. IN THE EVENT THAT DAMAGE OCCURS WITHIN THE RIGHT-OF-WAY AND THE COUNTY IS REQUIRED TO PERFORM CLEANUP, THE CONTRACTOR SHALL BE RESPONSIBLE FOR COUNTY REIMBURSEMENT OF ALL ASSOCIATED COSTS OR DAMAGE.
- ALL PROJECTS INVOLVING SITE DISTURBANCE OF ONE ACRE OR GREATER SHALL COMPLY WITH THE REQUIREMENTS OF THE NATIONAL POLLUTANT DISCHARGE ELIMINATION SYSTEM (NPDES). THE CONTRACTOR SHALL SUBMIT A NOTICE OF INTENT (NOI) TO COMPLY WITH THE GENERAL PERMIT FOR CONSTRUCTION ACTIVITY WITH THE REGIONAL WATER QUALITY CONTROL BOARD (RWQCB). THE CONTRACTOR SHALL PROVIDE THE COUNTY WITH THE WASTE DISCHARGE IDENTIFICATION NUMBER (WQID #) OR THWI VERIFICATION THAT AN EXEMPTION HAS BEEN GRANTED BY RWQCB. WQID NO.: 3 40C380690.

PIPELINE NOTES

- PIPELINE ELEVATIONS SHOWN ARE FOR INVERT OF PIPE UNLESS NOTED OTHERWISE. PIPELINES SHALL SLOPE UNIFORMLY BETWEEN INVERT ELEVATIONS SHOWN. CONTRACTOR SHALL PROVIDE ALL SHORTS, SPOOLS, AND FITTINGS NECESSARY TO MEET ELEVATIONS SPECIFIED.
- ALL HORIZONTAL OR VERTICAL CHANGES IN PIPE ALIGNMENT DELINEATED ON THE PLANS AS SHOWN WITHOUT FITTINGS SHALL BE INSTALLED IN ACCORDANCE WITH MANUFACTURER'S RECOMMENDATIONS FOR PIPE DEFLECTION. DO NOT BEND THE PIPE WITH MACHINERY. PROTECT JOINTS FROM OFFSET WHILE BENDING THE PIPE. IF BENDING THE PIPE WITHIN THE MANUFACTURER'S RECOMMENDATION IS INADEQUATE TO MEET THE REQUIRED ALIGNMENT, CONTRACTOR SHALL USE HIGH DEFLECTION COUPLINGS.
- CONNECTIONS MADE BETWEEN DIFFERENT CLASSES OF PIPE SHALL BE MADE WITH MATERIALS RATED FOR THE HIGHER PRESSURE CLASS.
- ALL NEW VALVES SHALL BE FLANGED DIRECTLY TO A TEE, CROSS OR OTHER FITTING. VALVES SHALL BE ACCESSIBLE FOR OPERATION WITH COMPLETE VALVE BOX PRIOR TO CONNECTION TO EXISTING WATER SYSTEM.
- PIPELINES SHALL BE HYDROSTATICALLY TESTED PRIOR TO PLACING COMPACTED BASE OR PAVEMENT.
- ALL HYDROSTATIC TESTING AND DISINFECTION SHALL BE MADE IN THE PRESENCE OF THE ENGINEER. HYDROSTATIC TEST PRESSURE SHALL BE IN ACCORDANCE WITH SHEET ##-###. TESTING AGAINST VALVES OR THROUGH FLEX-TEND EXPANSION JOINTS IS NOT PERMITTED. CONTRACTOR SHALL INSTALL BULKHEADS AND TOP OUTLETS AS REQUIRED FOR TESTING. END CAPS SHALL BE INSTALLED ON THE NEWLY CONSTRUCTED SIDE OF ALL CONNECTION POINTS AND NEW PIPING SHALL PASS ALL TESTING PRIOR TO CONNECTION TO THE EXISTING WATER SYSTEM.

APPLICABLE CODES

- 2022 CALIFORNIA BUILDING CODE
- 2022 CALIFORNIA FIRE CODE
- 2019 CALIFORNIA GREEN BUILDING STANDARDS CODE (CAL GREEN)
- 2022 CALIFORNIA TITLE 24: 2016 CALIFORNIA ENERGY CODE AND ACCESSIBILITY STANDARDS
- COUNTY ORDINANCE(S) TITLE 19, 22

TRAFFIC CONTROL

- CONTRACTOR SHALL PROVIDE ADEQUATE TRAFFIC CONTROL DURING ALL PHASES OF THE WORK PER A COUNTY PUBLIC WORKS DEPARTMENT APPROVED TRAFFIC CONTROL PLAN.

DRAFT - NOT FOR CONSTRUCTION

<p>WARNING IF THIS BAR DOES NOT MEASURE 1" THEN DRAWING IS NOT TO SCALE.</p>				DESIGNED MNR DRAWN PMD CHECKED DSW SCALE _____	PREPARED BY: MATTHEW N. RODRIGUES DATE _____ RCE No.: 84311	HERITAGE RANCH COMMUNITY SERVICES DISTRICT 4870 HERITAGE ROAD PASO ROBLES, CA 93446 APPROVED: _____ POSITION _____ DATE _____	WATER RESOURCE RECOVERY FACILITY UPGRADE CIVIL CIVIL NOTES 1	DRAWING 01-C001 SHEET X OF X PROJECT # _____
REV	DATE	BY	DESCRIPTION					

\\EgnyteDrive W Drive\3.0 Clients\Heritage Ranch Community Services District\10090 WRF Upgrade Design\6.0 Working Files\CAD\1-SHEET FILES\C-HRCSO-WWTP - Site.dwg 11/10/2023 4:20 PM Chris Durbin

SURVEYOR'S NOTES

- NO TITLE SEARCH (TITLE REPORT) WAS PROVIDED TO THE SURVEYOR. EASEMENTS WHICH MAY AFFECT THE SUBJECT PROPERTY HAVE NOT BEEN PLOTTED.
- ONLY THE SURFACE EVIDENCE OF UNDERGROUND UTILITIES HAVE BEEN MEASURED IN THE FIELD ON THIS SURVEY. IF APPROXIMATE UNDERGROUND ALIGNMENTS ARE SHOWN, I MAKE NO WARRANTY AS TO THE ACTUAL LOCATION, TYPE OR DEPTH OF THOSE UNDERGROUND UTILITIES. CALL UNDERGROUND SERVICE ALERT (USA) AT 1-800-642-2444 TO VERIFY THE ACTUAL LOCATION OF UTILITIES PRIOR TO ANY EXCAVATION. THE SURVEYOR ALSO HAS MADE NO INVESTIGATION AS TO SUBSURFACE ENVIRONMENTAL CONDITIONS THAT WOULD AFFECT THE USE OR DEVELOPMENT OF THIS PROPERTY.
- THE SIGNED AND SEALED ORIGINAL DRAWING OF THIS MAP CONSTITUTES THE FINAL WORK PRODUCT. MBS LAND SURVEYS WILL NOT BE LIABLE FOR ELECTRONIC VERSIONS OF THIS MAP PROVIDED TO OTHER PARTIES.
- THE BOUNDARY LINES SHOWN HEREON WERE COMPILED FROM RECORD INFORMATION (I.E. RECORDED MAPS OR DEEDS) AND ARE NOT INTENDED TO REPRESENT THE TRUE OR ACTUAL BOUNDARY LINES OF THE SUBJECT PROPERTY. TO DETERMINE THE ACTUAL BOUNDARIES OF THE PARCEL WILL REQUIRE A COMPLETE BOUNDARY SURVEY, THE SETTING OF PROPERTY MONUMENTS AND THE FILING OF A CORNER RECORD OR RECORD OF SURVEY IN CONFORMANCE WITH STATE LAW (LS ACT SEC. 8762). APPROXIMATE DIMENSIONAL TIES FROM THE BOUNDARY LINES SHOWN TO PHYSICAL FEATURES (E.G. BUILDINGS, FENCES, WALLS OR TREES, ETC.) SHOWN ON THIS MAP CAN BE DERIVED BY SCALING THE FINISHED WORK PRODUCT WHICH IS PLOTTED AT THE SCALE INDICATED.

BASIS OF BEARING

THE COORDINATES AND BEARINGS AS MEASURED AND SHOWN HEREON ARE ON GRID AND ARE BASED UPON THE CALIFORNIA COORDINATE SYSTEM OF 1983, CCS83, ZONE 5 0405, (1991.35 EPOCH) IN ACCORDANCE WITH THE CALIFORNIA PUBLIC RESOURCES CODE SECTIONS 8801-8819; SAID COORDINATES AND BEARINGS ARE BASED LOCALLY UPON FIELD-OBSERVED TIES TO THE FOLLOWING CALIFORNIA SPATIAL REFERENCE NETWORK, NGS, CAL TRANS, OR EQUIVALENT STATIONS.

BASIS OF BEARINGS IS BASED UPON AN INVERSE (BEARING N57° 27' 49"E) BETWEEN THE FOLLOWING TWO STATIONS PROVIDED BY JOANN HEAD, LS:

REFERENCED CONTROL STATIONS CONNECTED:

STATION	NORTHING(ft)	EASTING(ft)	ELEV.	VERT. DATUM	
5007	2,461,129.5338	5,705,353.457	889.8	NAVD88	AERIAL CONTROL TARGET
5014	2,462,713.6152	5,707,836.4931	1023.1	NAVD88	AERIAL CONTROL TARGET

MAPPING ANGLE AND GRID FACTOR:

STATION	NORTHING(ft)	EASTING(ft)	MAPPING ANGLE	COMB. FACTOR	ELEV.(88)	ELLIP.
5007	2,461,129.534	5,705,353.457	-1°38'39.894"	0.9999715	1023.1	774.2011

MEASURED DISTANCES SHOWN HEREON OR INVERSED FROM COORDINATES SHOWN HEREON ARE IN REFERENCE TO CCS83. TO APPROXIMATE LOCAL GROUND DISTANCES DIVIDE BY THE COMBINATION FACTOR PROVIDED HEREON.

BENCHMARK

THE INITIAL BENCH MARK FOR THIS PROJECT IS AN OPUS SOLUTION BY JOANN HEAD, LS.

SITE DATA:

ADDRESS: HERITAGE RANCH CSD WWTP, PASO ROBLES
 ASSESSOR'S PARCEL NO. 012-181-085

BASIS OF SURVEY

THIS MAP REPRESENTS AN AERIAL TOPOGRAPHIC SURVEY PERFORMED BY CENTRAL COAST AERIAL MAPPING, PHOTOGRAPHY DATED JUNE 11TH, 2019, JOB NO. 21-276, WITH GROUND CONTROL SET BY JOANN HEAD, AND SUPPLEMENTAL TOPOGRAPHIC SURVEYING BY MBS LAND SURVEYS FEBRUARY 2ND, 2022.
 CONTACT: ROBERT LAFICA, CCAM 805-543-4307

DRAFT - NOT FOR CONSTRUCTION

REV	DATE	BY	DESCRIPTION

WARNING

IF THIS BAR DOES NOT MEASURE 1" THEN DRAWING IS NOT TO SCALE.

DESIGNED	MNR
DRAWN	PMD
CHECKED	DSW
SCALE	

PREPARED BY:
 MATTHEW N. RODRIGUES
 RCE No.: 84311

DATE _____



805 AEROVISTA PLACE, SUITE 201 SAN LUIS OBISPO, CA 93401
 PHONE: (805) 457-8833 FAX: (805) 888-2764

HERITAGE RANCH COMMUNITY SERVICES DISTRICT
 4870 HERITAGE ROAD
 PASO ROBLES, CA 93446

APPROVED: _____
 _____ POSITION DATE

WATER RESOURCE RECOVERY FACILITY UPGRADE
 CIVIL
CIVIL NOTES 2

DRAWING
01-C002
 SHEET X OF X
 PROJECT # _____

\\EgnyteDrive W Drive\3.0 Clients\Heritage Ranch Community Services District 1029\10090 WRF Upgrade Design\6.0 Working Files\0-CAD\1-SHEET FILES\C-HRCSD-WWTP - Site.dwg 11/10/2023 4:20 PM Chris Durbin

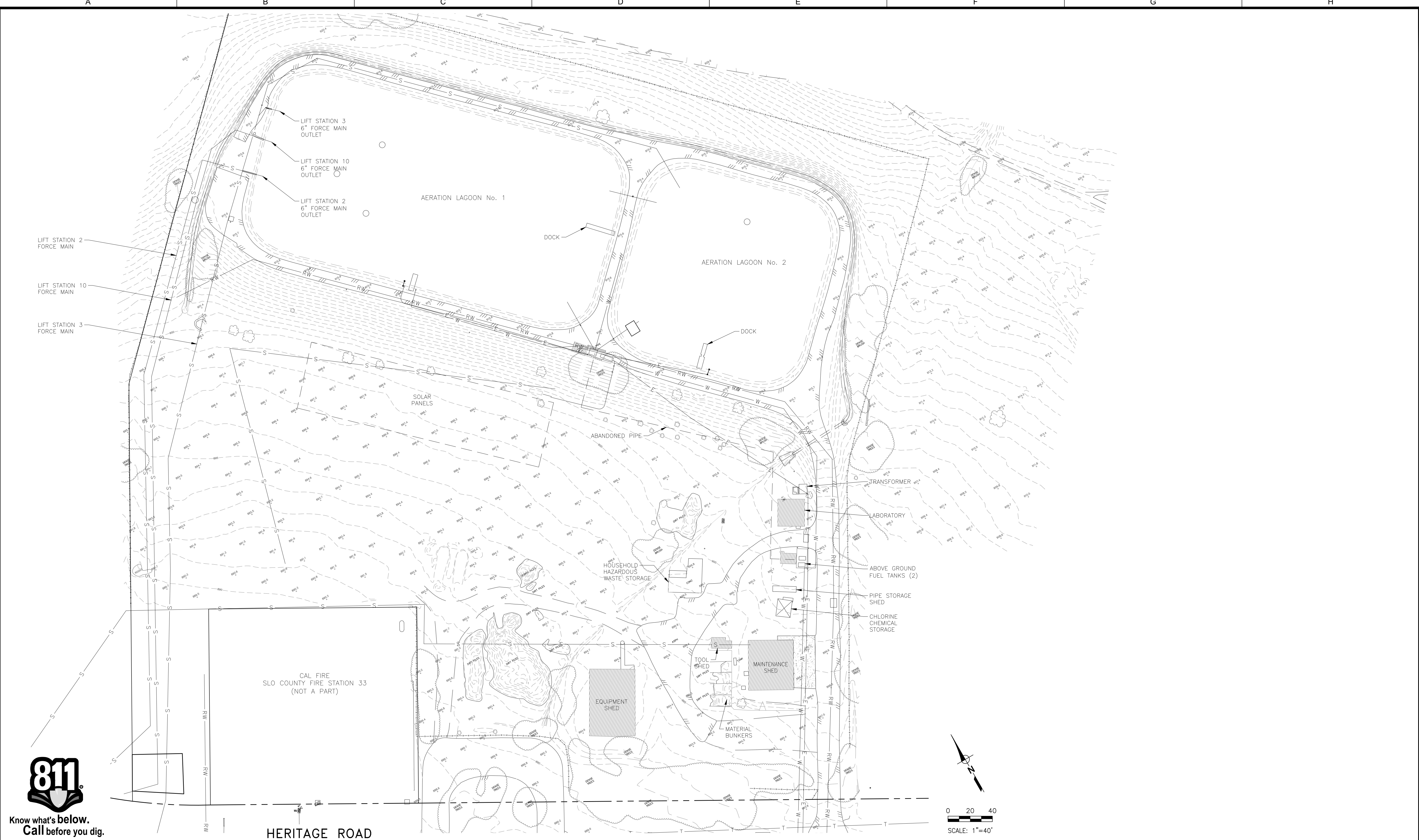

Know what's below.
Call before you dig.

HERITAGE ROAD

PLAN

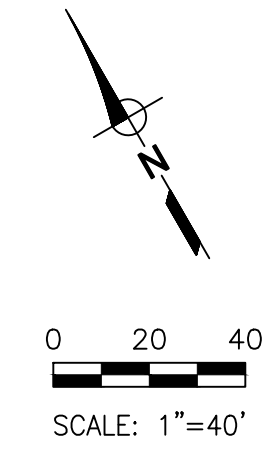

DRAFT - NOT FOR CONSTRUCTION

REV	DATE	BY	DESCRIPTION

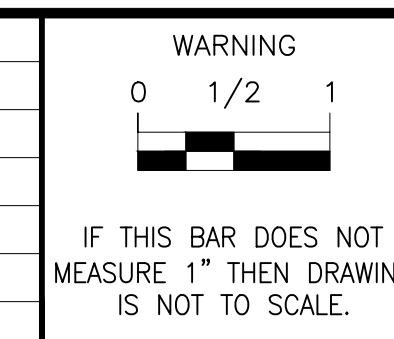

DESIGNED	MNR
DRAWN	PMD
CHECKED	DSW
SCALE	1"=40'

PREPARED BY:	MATTHEW N. RODRIGUES	DATE	
RCE No.:	84311		

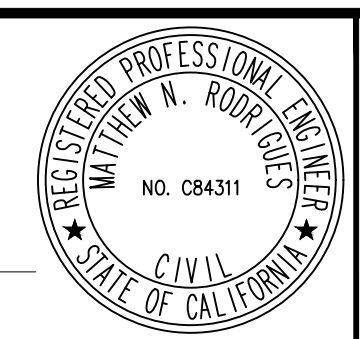

605 AEROVISTA PLACE, SUITE 201
 PHONE: (805) 457-8833
 SAN LUIS OBISPO, CA 93401
 FAX: (805) 888-2764

HERITAGE RANCH COMMUNITY SERVICES DISTRICT 4870 HERITAGE ROAD PASO ROBLES, CA 93446	APPROVED: _____ POSITION _____ DATE _____
---	---

WATER RESOURCE RECOVERY FACILITY UPGRADE CIVIL	EXISTING SITE CONDITIONS
---	--------------------------

DRAWING 01-C101 SHEET X OF X PROJECT # _____

\\egnyte\drive\w Drive\3.0 Clients\Heritage Ranch Community Services District 1029\10090 WRF Upgrade Design\6.0 Working Files\0-CAD\1-SHEET FILES\C-HRCSD-WWTP - Site.dwg 11/10/2023 4:20 PM Chris Durbin

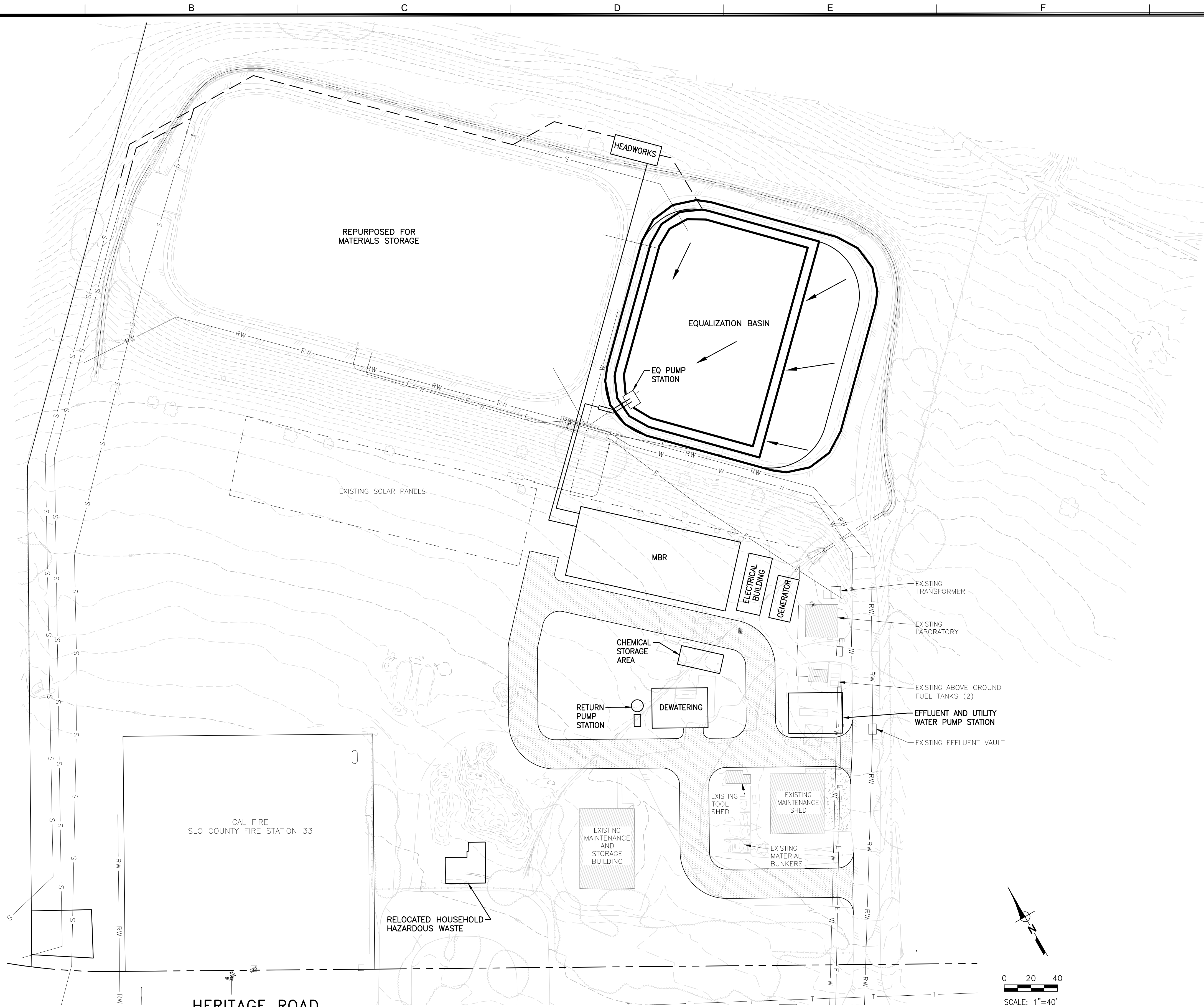

Know what's below.
Call before you dig.

HERITAGE ROAD

PLAN

DRAFT - NOT FOR CONSTRUCTION

REV	DATE	BY	DESCRIPTION

WARNING

IF THIS BAR DOES NOT MEASURE 1" THEN DRAWING IS NOT TO SCALE.

DESIGNED	MNR
DRAWN	PMD
CHECKED	DSW
SCALE	1"=40'

PREPARED BY:
MATTHEW N. RODRIGUES
RCE No.: 84311

DATE



605 AEROVISTA PLACE, SUITE 201
PHONE: (805) 457-8833

SAN LUIS OBISPO, CA 93401
FAX: (805) 888-2764

HERITAGE RANCH COMMUNITY SERVICES DISTRICT
4870 HERITAGE ROAD
PASO ROBLES, CA 93446

APPROVED: _____ POSITION _____ DATE _____

WATER RESOURCE RECOVERY FACILITY UPGRADE
CIVIL

SITE PLAN

DRAWING
01-C102
SHEET X OF X
PROJECT # _____

W:\3.0 Clients\Heritage Ranch Community Services District 1029\10090 WRF Upgrade Design\6.0 Working Files\0-CAD\1-SHEET FILES\C-HRCSO-WWTP - YardPiping.dwg 11/10/2023 8:48 PM Mary Harrington

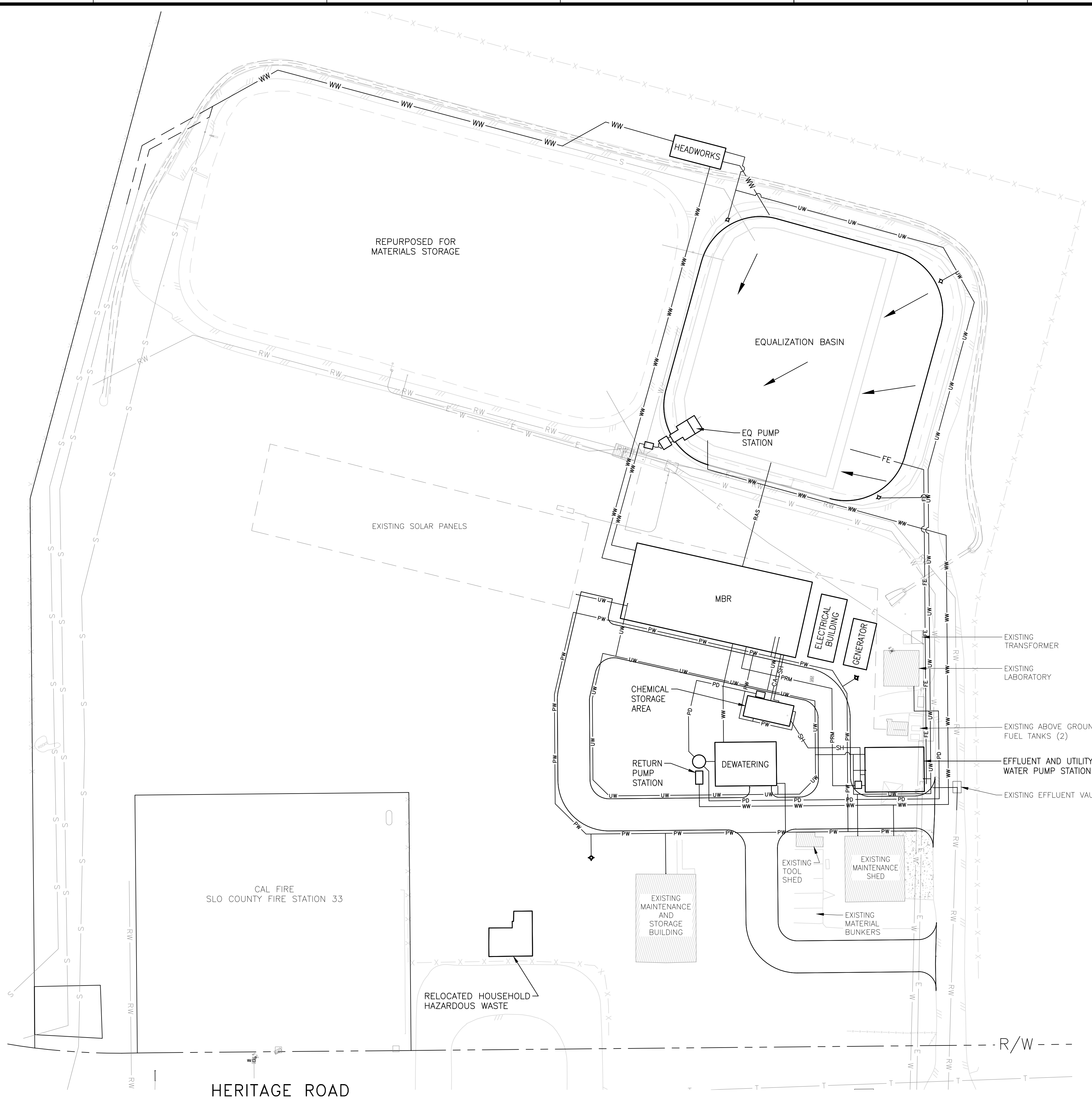

Know what's below.
Call before you dig.

HERITAGE ROAD

PLAN

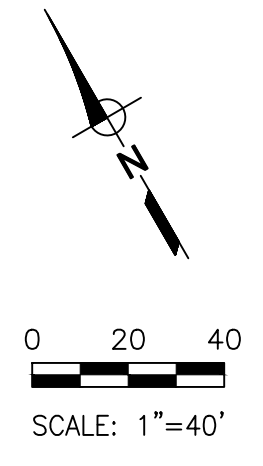

DRAFT - NOT FOR CONSTRUCTION

REV	DATE	BY	DESCRIPTION

WARNING

IF THIS BAR DOES NOT MEASURE 1" THEN DRAWING IS NOT TO SCALE.

DESIGNED	MNR
DRAWN	PMD
CHECKED	DSW
SCALE	1"=40'

PREPARED BY:
MATTHEW N. RODRIGUES
RCE No.: 84311

DATE

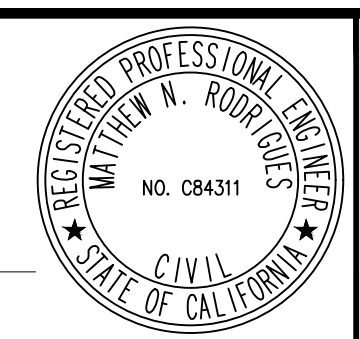

WSC

805 AEROVISTA PLACE, SUITE 201
PHONE: (805) 457-8833

SAN LUIS OBISPO, CA 93401
FAX: (805) 888-2764

HERITAGE RANCH COMMUNITY SERVICES DISTRICT
4870 HERITAGE ROAD
PASO ROBLES, CA 93446

APPROVED: _____ POSITION _____ DATE _____

WATER RESOURCE RECOVERY FACILITY UPGRADE
CIVIL

YARD PIPING PLAN

DRAWING
01-C103
SHEET X OF X
PROJECT # _____

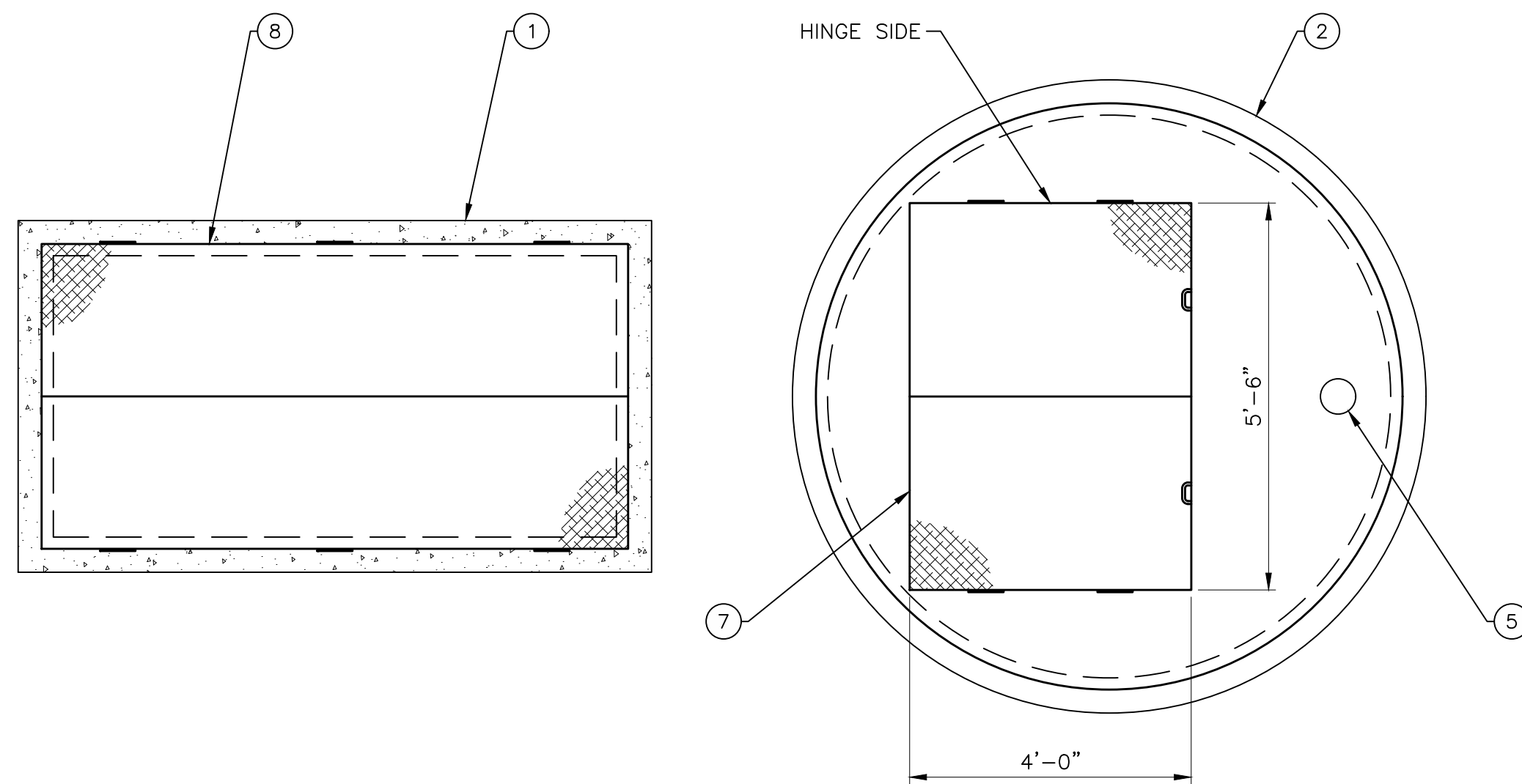

IN PLANT RETURN PUMP STATION TOP PLAN

SCALE: 1/2"=1'-0"

SHEET KEY NOTES

- ① PRECAST CONCRETE VALVE VAULT PER SPECIFICATIONS
- ② 8' ID PRECAST WET WELL PER SPECIFICATIONS
- ③ 3" MAGNETIC FLOW METER PER SPECIFICATIONS
- ④ LIFTING CHAIN WITH POWER CABLE
- ⑤ 3" STEEL PIPE VENT
- ⑥ LEVEL SENSING MULTITRODE FOR GRINDER PUMP
- ⑦ WET WELL LID, H2O TRAFFIC RATING PER SPECIFICATIONS
- ⑧ 4'X8' DOUBLE LEAF, SPRING ASSIST HATCH H2O TRAFFIC RATING, PER SPECIFICAITONS
- ⑨ FOR CONTINUATION SEE YARD PIPING PLAN ON SHEET _

GENERAL NOTES

- 1. NOTES

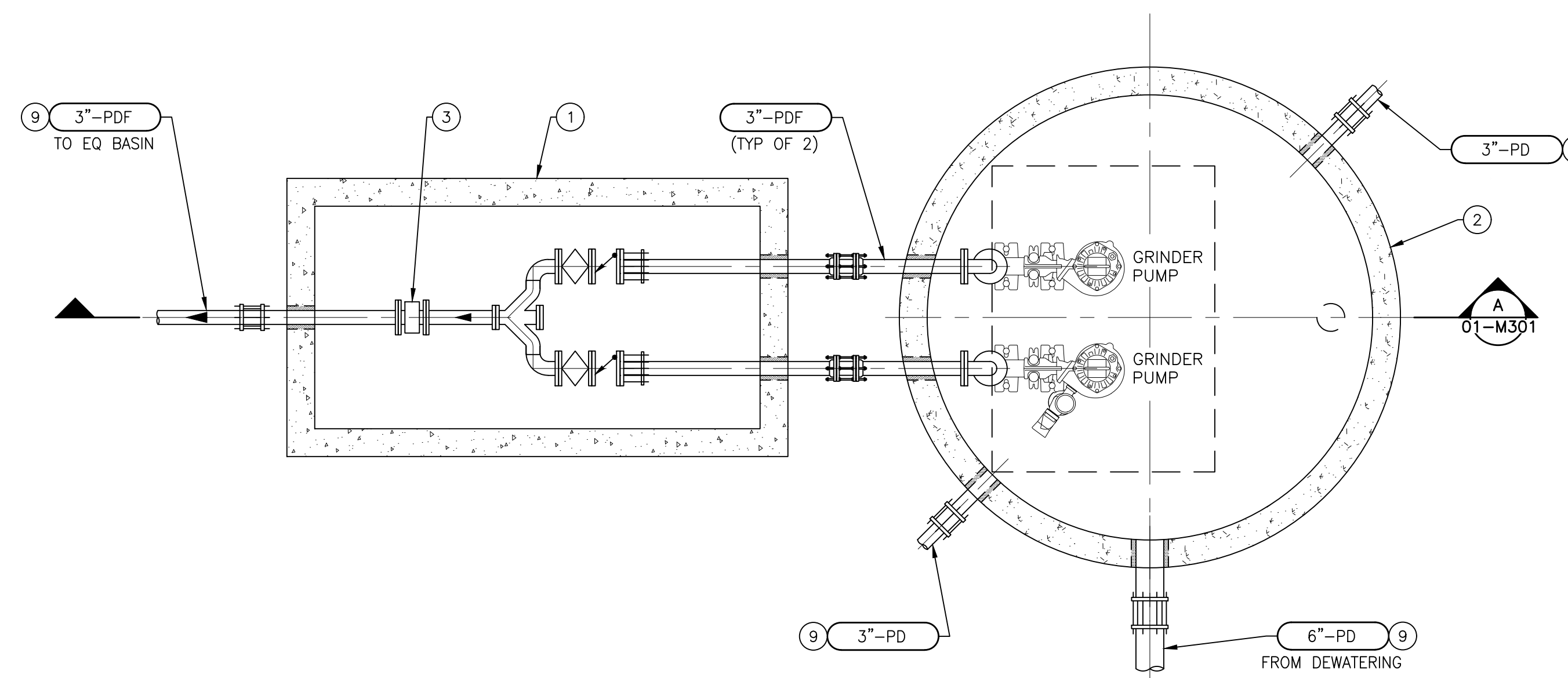

IN PLANT RETURN PUMP STATION BOTTOM PLAN

SCALE: 1/2"=1'-0"

DRAFT - NOT FOR CONSTRUCTION

W:\3.0 Clients\Heritage Ranch Community Services District 1029\10090 WRF Upgrade Design\6.0 Working Files\0-CAD\1-SHEET FILES\M-HRCSO-WWTF - 01 Return PS.dwg 11/18/2023 4:05 PM Mary Harrington

REV	DATE	BY	DESCRIPTION

WARNING

 IF THIS BAR DOES NOT MEASURE 1" THEN DRAWING IS NOT TO SCALE.

DESIGNED	KCS
DRAWN	PMD
CHECKED	DSW
SCALE	AS NOTED

PREPARED BY: _____
 DATE: _____

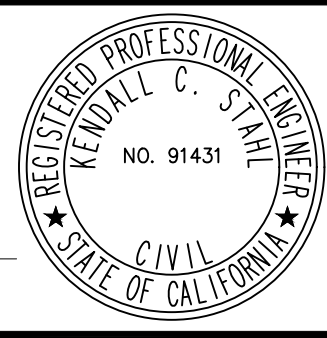

HERITAGE RANCH COMMUNITY SERVICES DISTRICT
 4870 HERITAGE ROAD
 PASO ROBLES, CA 93446

605 AEROVISTA PLACE, SUITE 201 SAN LUIS OBISPO, CA 93401
 PHONE: (805) 457-8833 FAX: (805) 888-2764

APPROVED: _____
 POSITION: _____ DATE: _____

WATER RESOURCE RECOVERY FACILITY UPGRADE
 MECHANICAL
IN-PLANT RETURN PUMP STATION PLANS

DRAWING
01-M101
 SHEET X OF X
 PROJECT # _____

W:\3.0 Clients\Heritage Ranch Community Services District\1029\10090 WRF Upgrade Design\6.0 Working Files\0-CAD\1-SHEET FILES\M-HRCSO-WWTP - 01 Return PS.dwg 11/8/2023 4:05 PM Mary Harrington

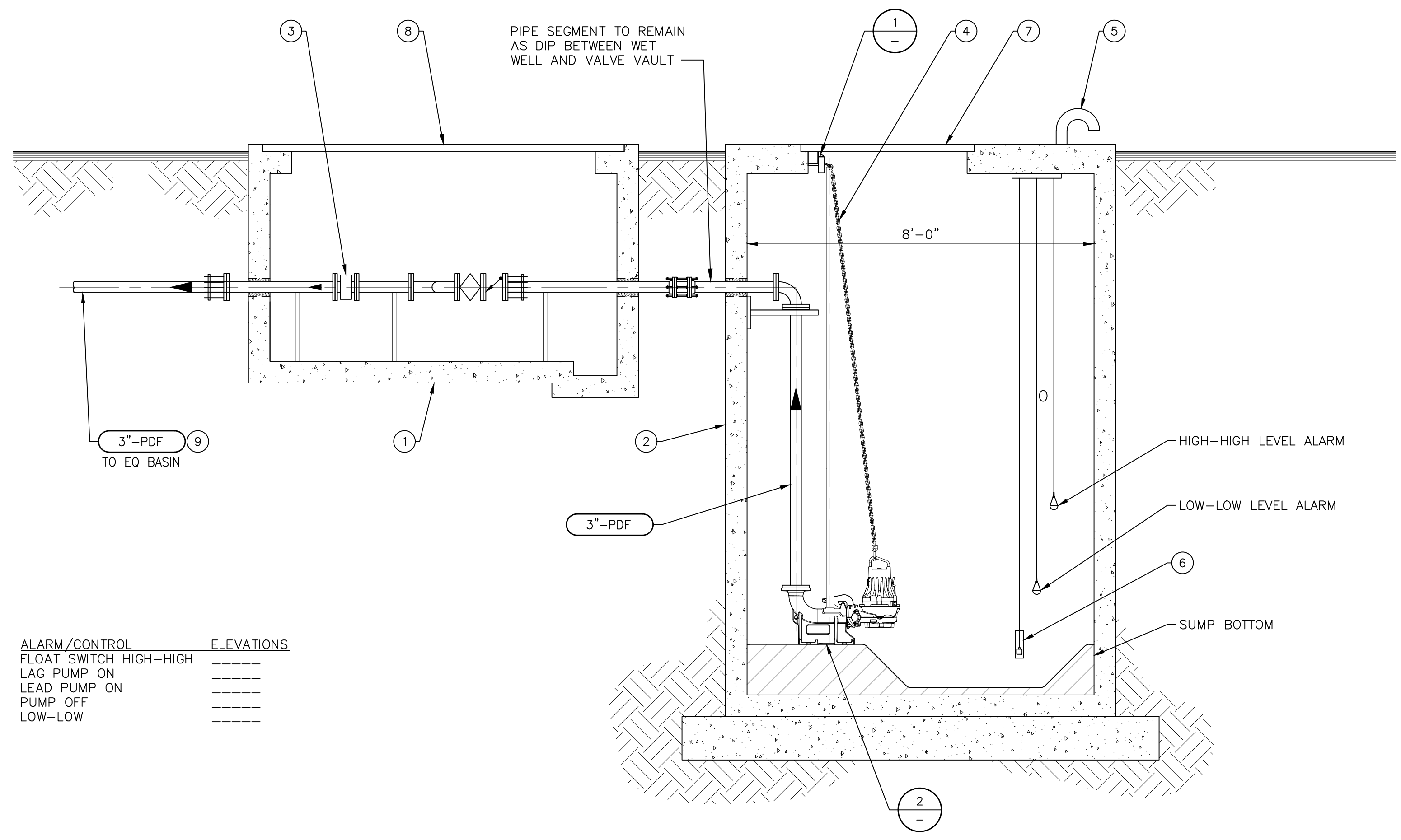

- SHEET KEY NOTES**
- ① PRECAST CONCRETE VALVE VAULT PER SPECIFICATIONS
 - ② 8' ID PRECAST WET WELL PER SPECIFICATIONS
 - ③ 3" MAGNETIC FLOW METER PER SPECIFICATIONS
 - ④ LIFTING CHAIN WITH POWER CABLE
 - ⑤ 3" STEEL PIPE VENT
 - ⑥ LEVEL SENSING MULTITRODE FOR GRINDER PUMP
 - ⑦ WET WELL LID, H2O TRAFFIC RATING PER SPECIFICATIONS
 - ⑧ 4'X8' DOUBLE LEAF, SPRING ASSIST HATCH H2O TRAFFIC RATING, PER SPECIFICATIONS
 - ⑨ FOR CONTINUATION SEE YARD PIPING PLAN ON SHEET _

ALARM/CONTROL	ELEVATIONS
FLOAT SWITCH HIGH-HIGH	-----
LAG PUMP ON	-----
LEAD PUMP ON	-----
PUMP OFF	-----
LOW-LOW	-----

GENERAL NOTES
1. NOTES

IN PLANT RETURN PUMP STATION SECTION
SCALE: 1/2"=1'-0"

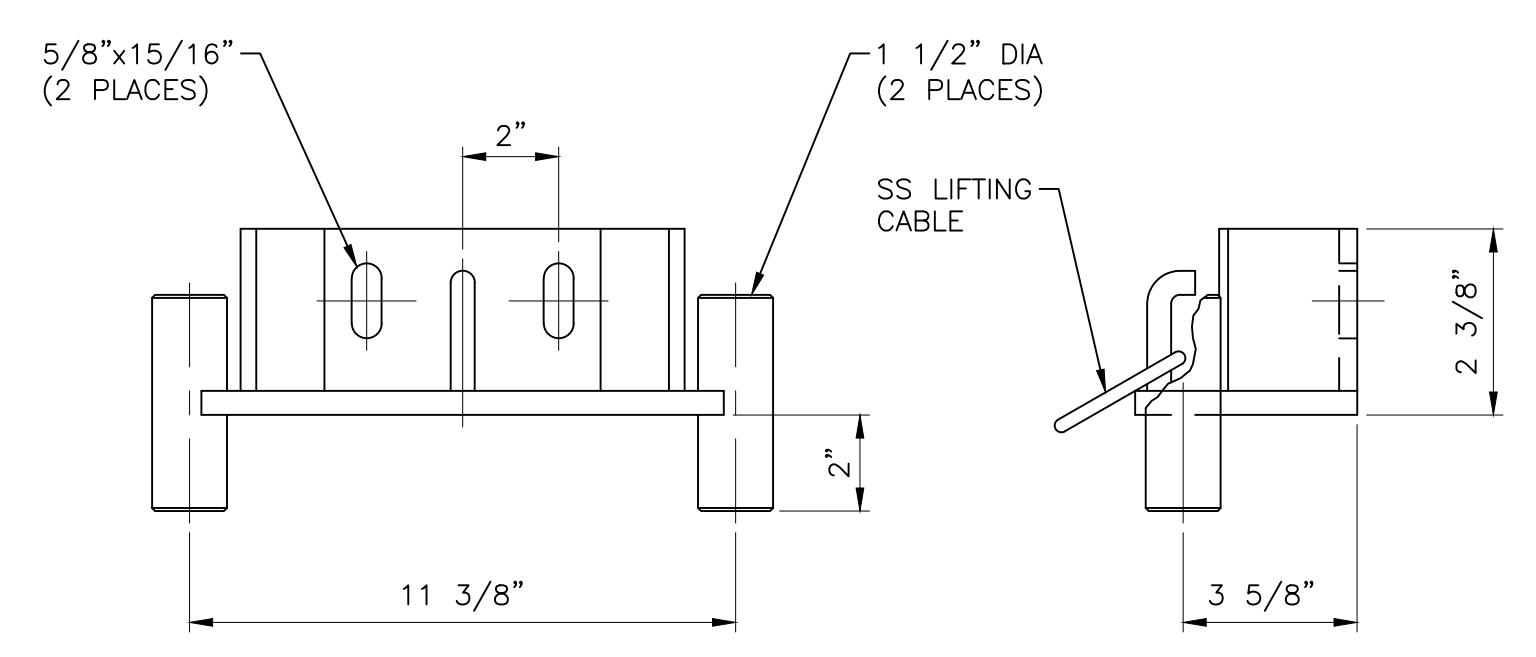

NOTE:
USE (2) 1 1/2" ANCHORS WITH APPROX 2"
MIN EMBEDMENT BRACKET TO BE TYPE 316 SS.

UPPER BRACKET DETAIL
SCALE: NTS

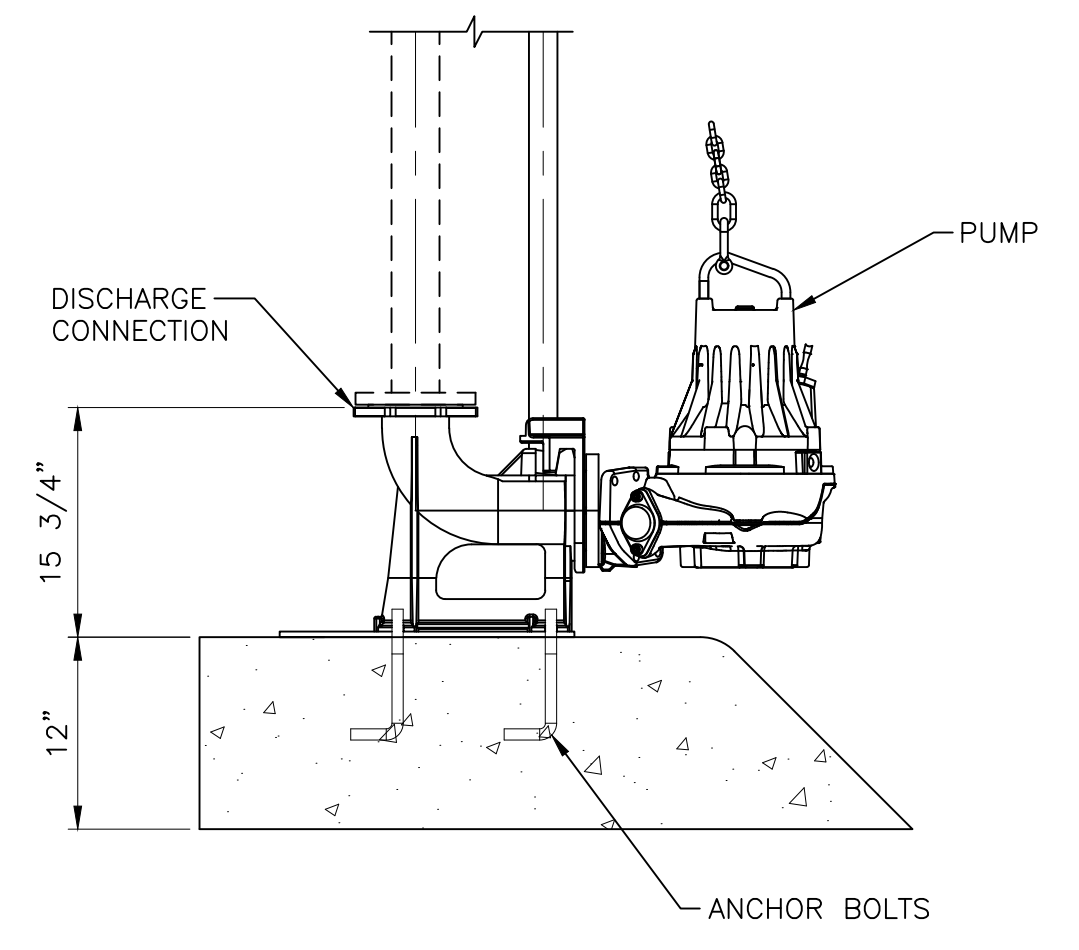

NOTE:
CONTRACTOR TO COORDINATE WITH PUMP
MANUFACTURER FOR FINAL CONFIGURATION.

PUMP MOUNTING DETAIL
SCALE: NTS

DRAFT - NOT FOR CONSTRUCTION

REV	DATE	BY	DESCRIPTION

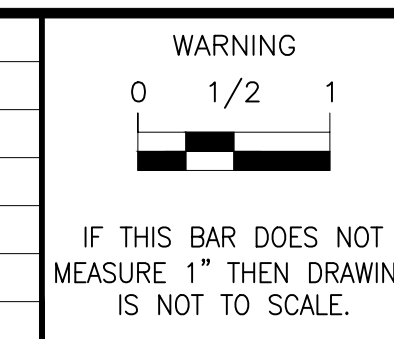

DESIGNED	KCH
DRAWN	PMD
CHECKED	DSW
SCALE	1/2"=1'-0"

PREPARED BY: _____
DATE: _____



WSC
605 AEROVISTA PLACE, SUITE 201 SAN LUIS OBISPO, CA 93401
PHONE: (805) 457-8833 FAX: (805) 888-2764

HERITAGE RANCH COMMUNITY SERVICES DISTRICT
4870 HERITAGE ROAD
PASO ROBLES, CA 93446

APPROVED: _____
POSITION: _____ DATE: _____

WATER RESOURCE RECOVERY FACILITY UPGRADE
MECHANICAL
IN-PLANT RETURN PUMP STATION SECTIONS AND DETAILS

DRAWING
01-M301
SHEET X OF X
PROJECT # _____

W:\3.0 Clients\Heritage Ranch Community Services District\1029\10090 WRF Upgrade Design\6.0 Working Files\0-CAD\1-SHEET FILES\M-HRCSO-WWTP -- 02_Hawks.dwg 11/9/2023 3:04 PM Mary Horrington

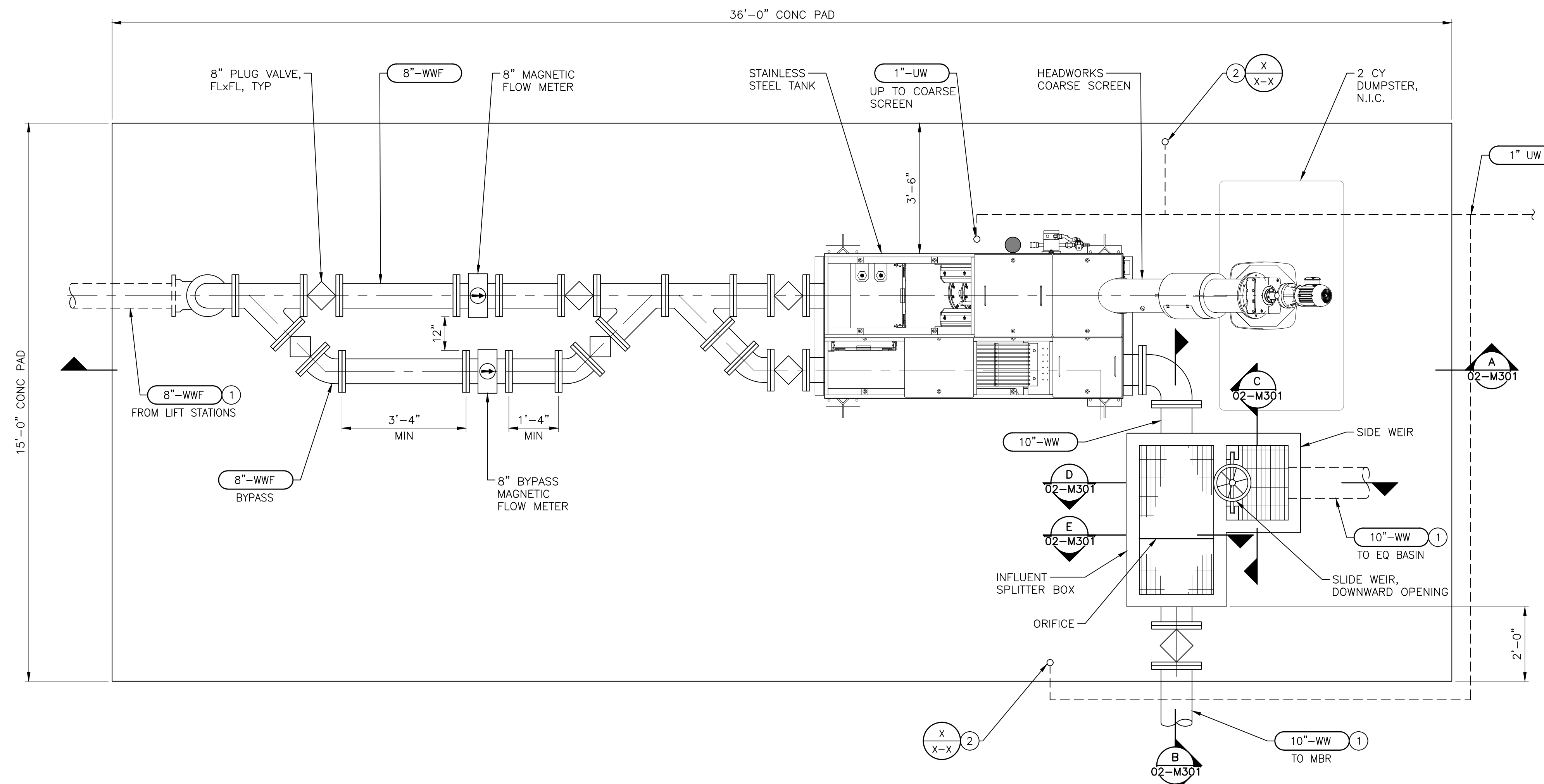

HEADWORKS PLAN
SCALE: 1/2"=1'-0"

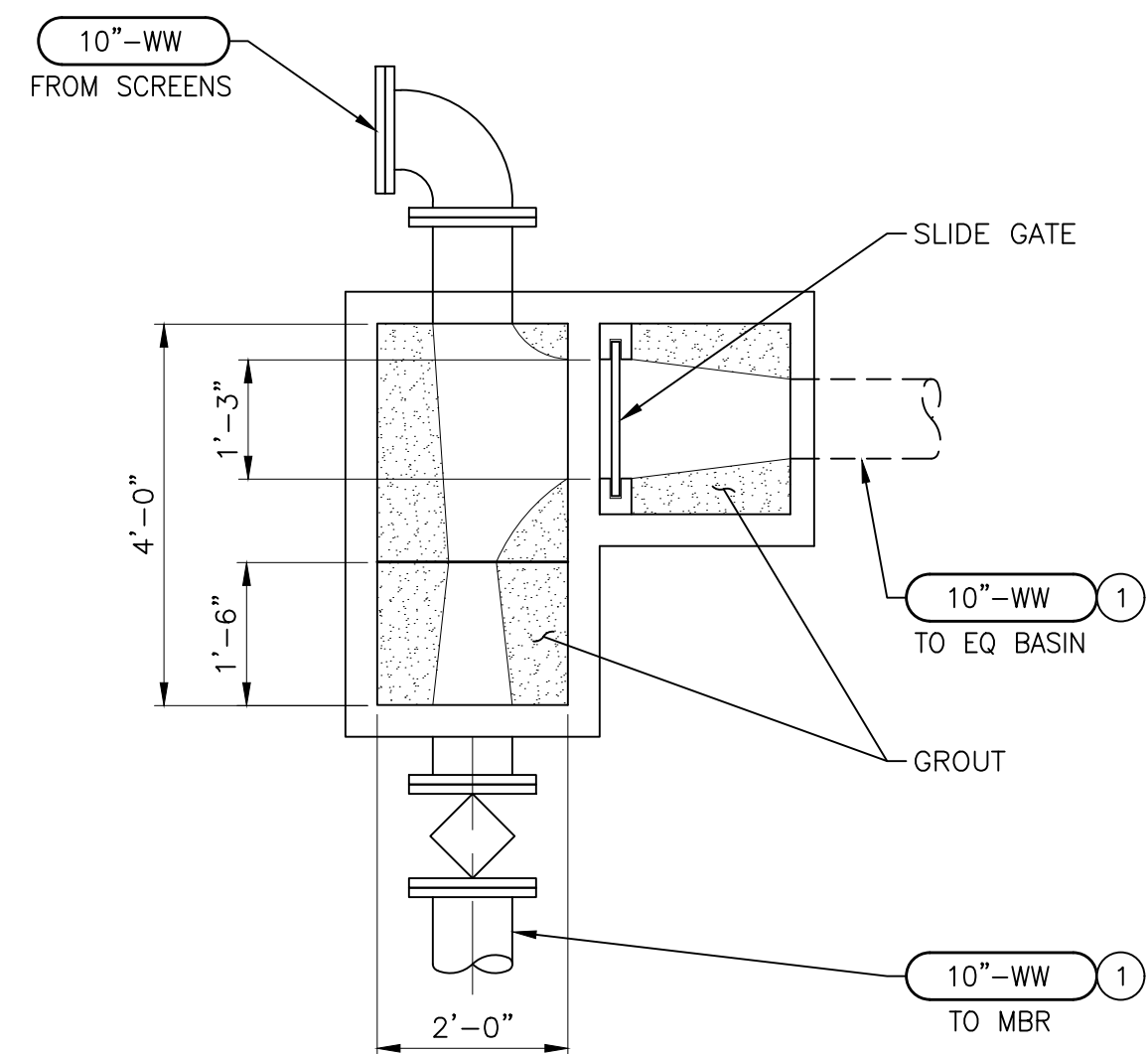

INFLUENT SPLITTER BOX BOTTOM PLAN
SCALE: 1/2"=1'-0"

SHEET KEY NOTES
 ① FOR CONTINUATION SEE YARD PIPING PLAN ON SHEET
 ② 1" HOSE BIB

GENERAL NOTES
 1. NOTES

DRAFT - NOT FOR CONSTRUCTION

REV	DATE	BY	DESCRIPTION

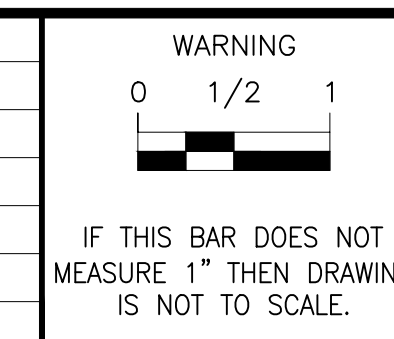

DESIGNED: KCH
 DRAWN: MAH
 CHECKED: DSW
 SCALE: 1/2"=1'-0"

PREPARED BY: _____
 DATE: _____

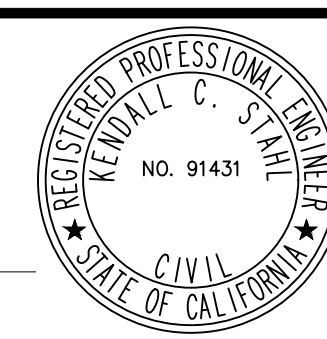

HERITAGE RANCH COMMUNITY SERVICES DISTRICT
 4870 HERITAGE ROAD
 PASO ROBLES, CA 93446
 APPROVED: _____
 POSITION: _____ DATE: _____

WATER RESOURCE RECOVERY FACILITY UPGRADE
 MECHANICAL
HEADWORKS PLAN

DRAWING
02-M101
 SHEET X OF X
 PROJECT # _____

W:\3.0 Clients\Heritage Ranch Community Services District\1029\10090 WRF Upgrade Design\6.0 Working Files\0-CAD\1-SHEET FILES\M-HRCSO-WWTP - 02_Hawks.dwg 11/9/2023 3:04 PM Mary Horrington

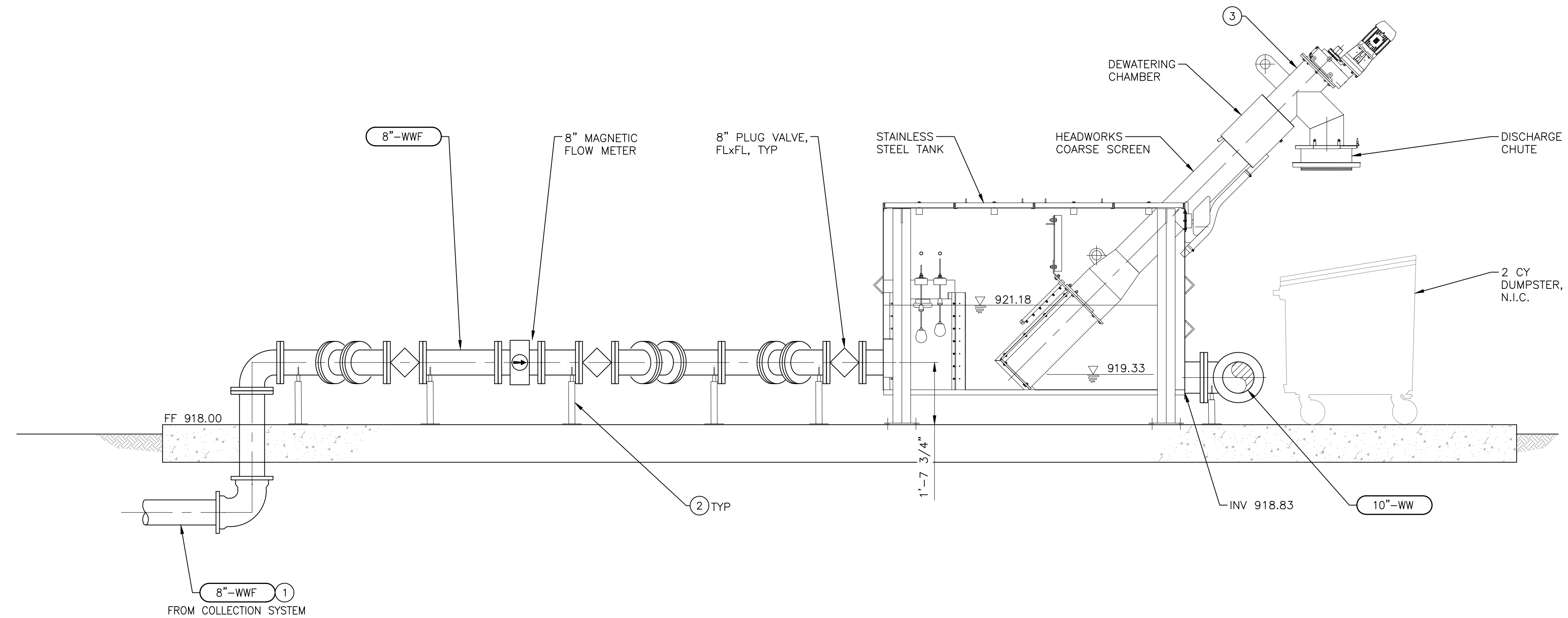

HEADWORKS SECTION A
SCALE: 1/2"=1'-0"

- SHEET KEY NOTES**
- ① FOR CONTINUATION SEE YARD PIPING PLAN ON SHEET
 - ② FLANGED PIPE SUPPORTS
 - ③ EQUIPMENT DIMENSIONS PER MANUFACTURER SUBMITTAL
 - ④ BASE PLATE AND ANCHORAGE PER MANUFACTURER SUBMITTAL
 - ⑤ OPENINGS IN FRP GRATING TO PASS SLIDE GATE
 - ⑥ 15"x15" DOWNWARD OPENING WEIR GATE
 - ⑦ 10" PLUG VALVE

- GENERAL NOTES**
1. NOTES

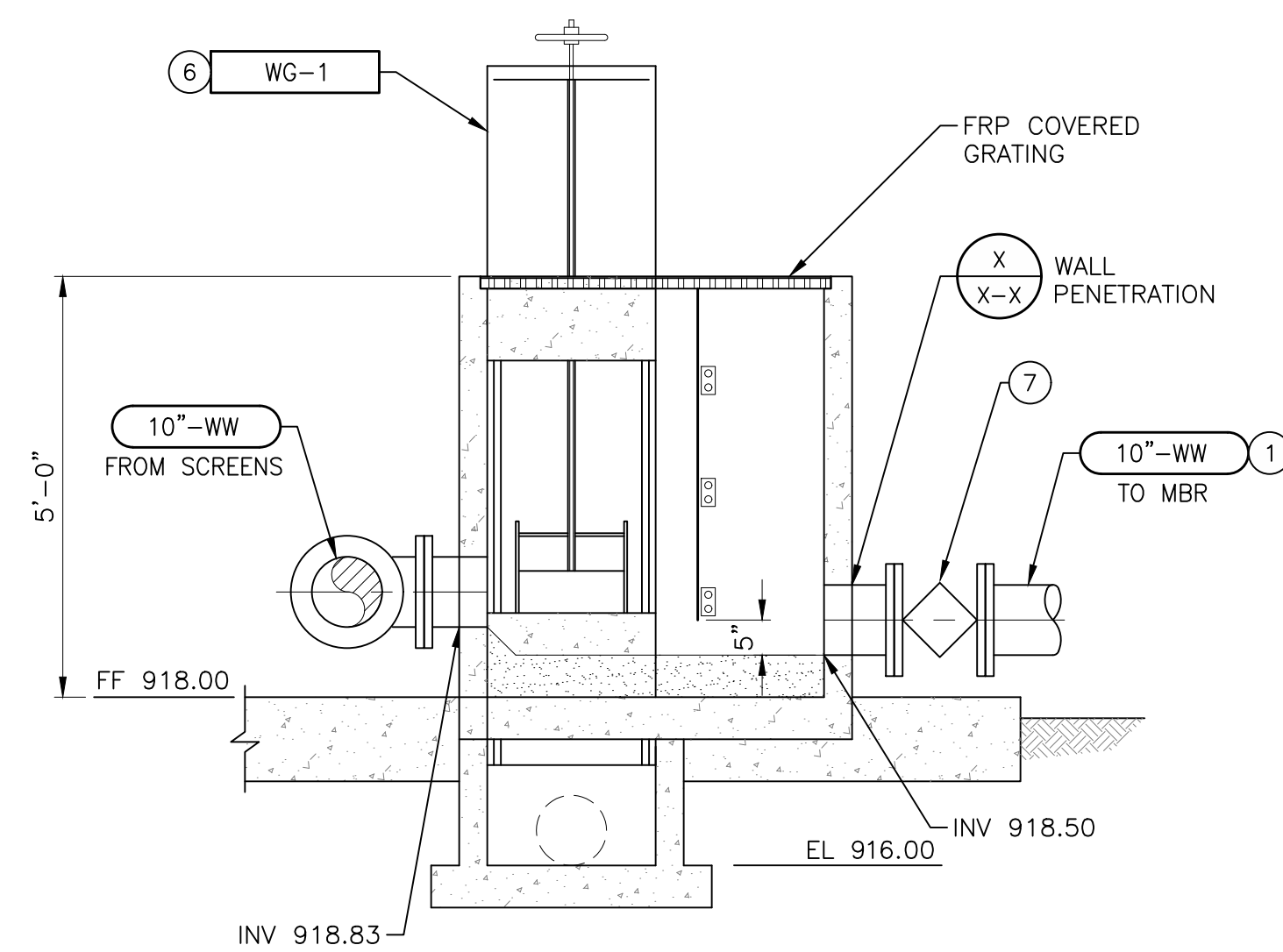

INFLUENT SPLITTER BOX SECTION B
SCALE: 1/2"=1'-0"

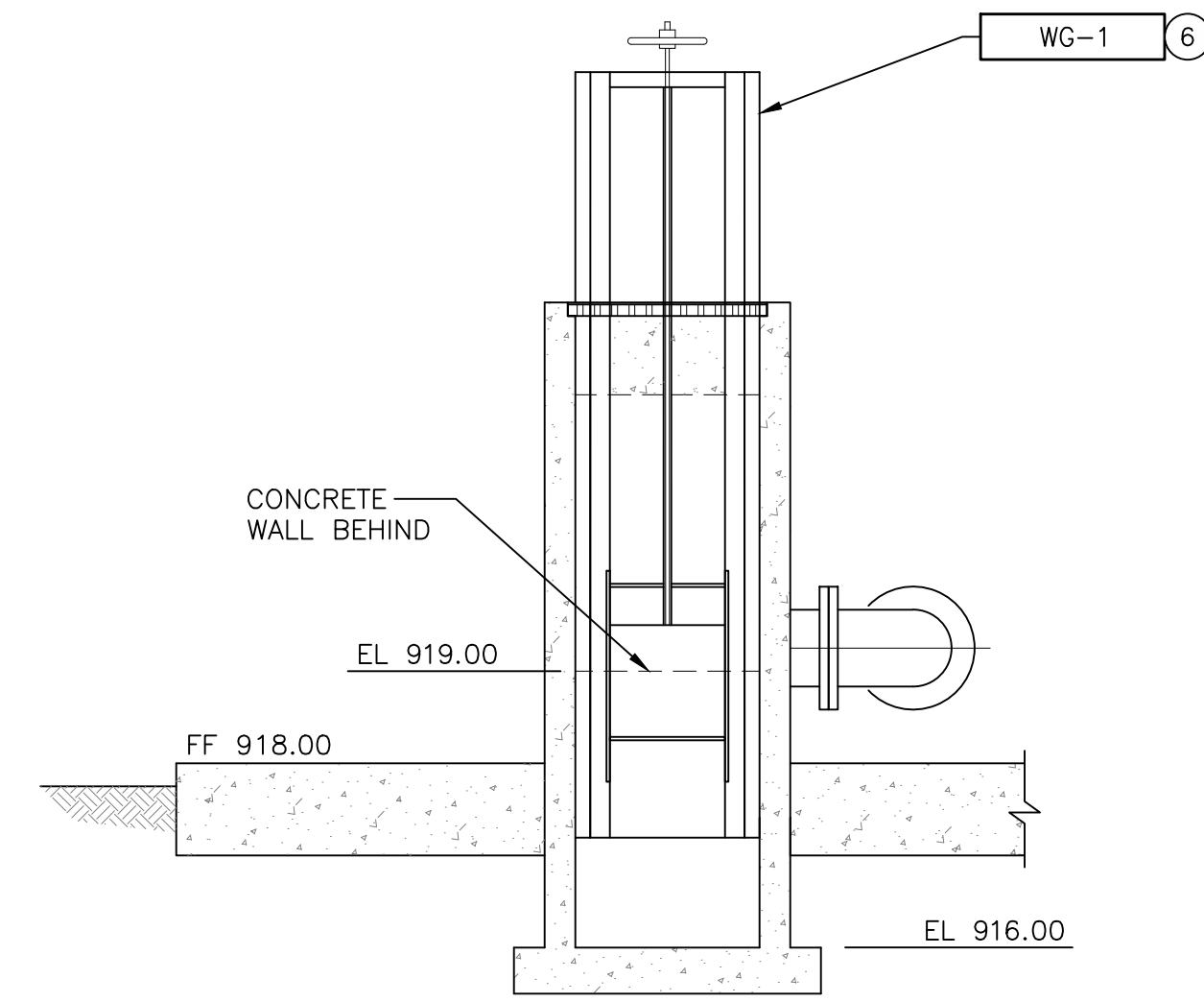

INFLUENT SPLITTER BOX SECTION C
SCALE: 1/2"=1'-0"

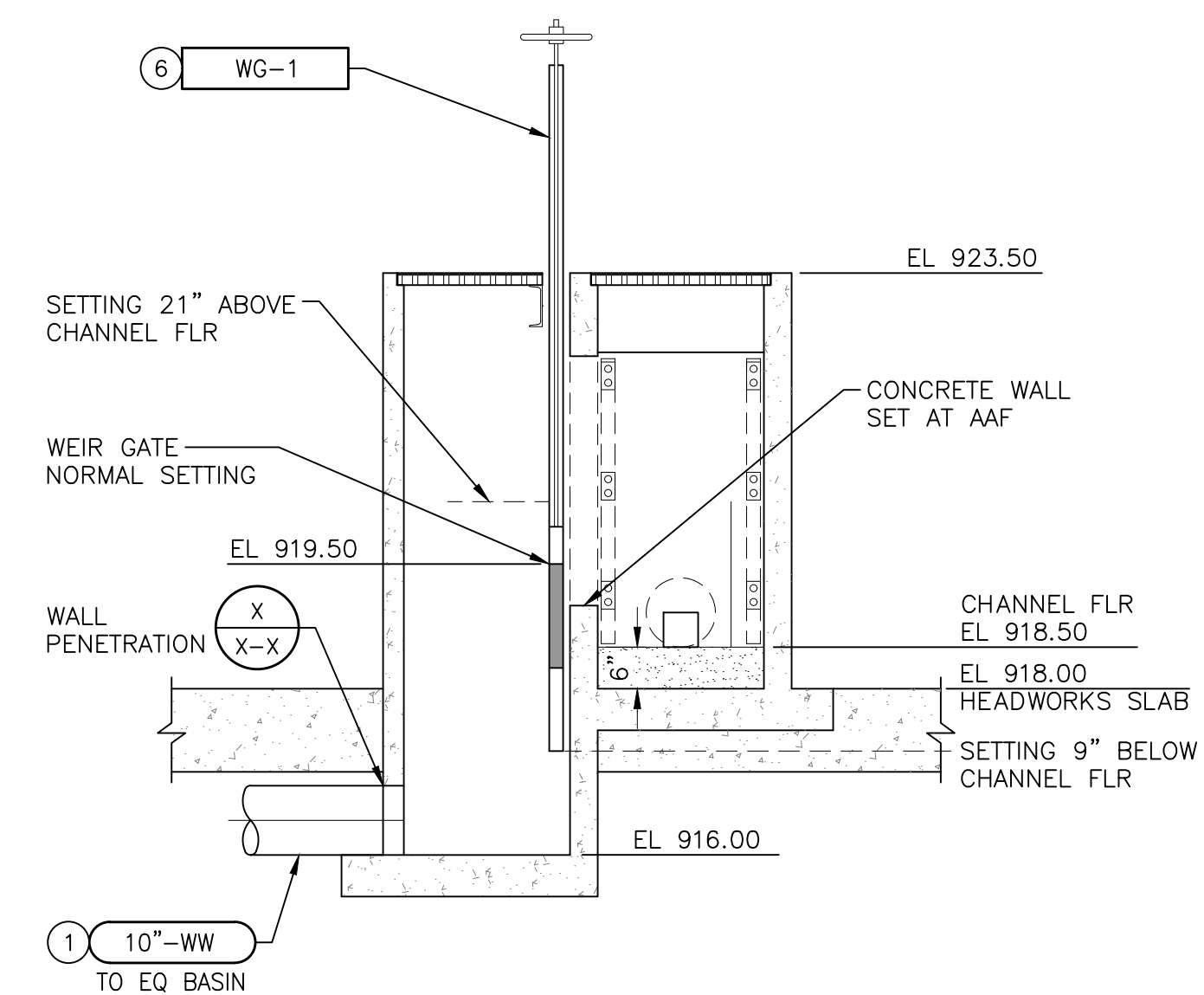

INFLUENT SPLITTER BOX SECTION D
SCALE: 1/2"=1'-0"

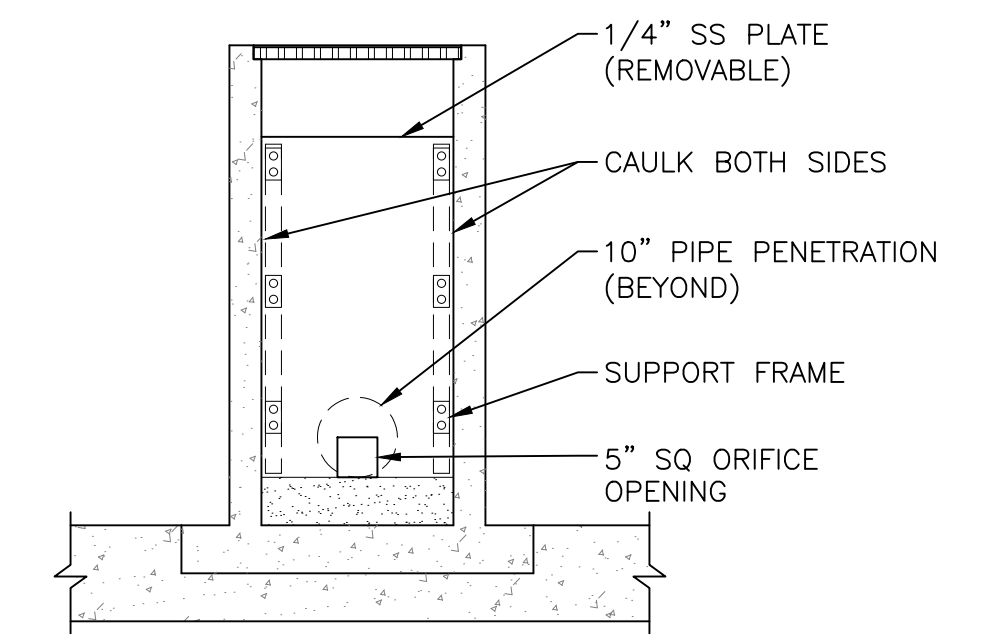

INFLUENT SPLITTER BOX SECTION E
SCALE: 1/2"=1'-0"

DRAFT - NOT FOR CONSTRUCTION

REV	DATE	BY	DESCRIPTION

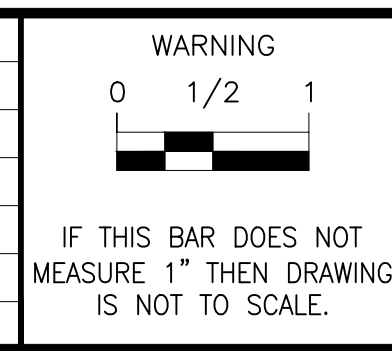

DESIGNED: KCH
DRAWN: MAH
CHECKED: DSW
SCALE: 1/2"=1'-0"

PREPARED BY: _____
DATE: _____



HERITAGE RANCH COMMUNITY SERVICES DISTRICT
4870 HERITAGE ROAD
PASO ROBLES, CA 93446

APPROVED: _____
POSITION: _____ DATE: _____

WATER RESOURCE RECOVERY FACILITY UPGRADE
MECHANICAL

HEADWORKS SECTIONS

DRAWING: **02-M301**
SHEET X OF X
PROJECT # _____

SHEET KEY NOTES

- ① SEE YARD PIPING PLAN FOR CONTINUATION
- ② FENCE
- ③ 4' SWING GATE
- ④ HDPE LADDER
- ⑤ WASHDOWN HYDRANT

GENERAL NOTES

- 1. THE EQUALIZATION BASIN IS DESIGNED TO ACCEPT PEAK FLOWS FROM THE HEADWORKS. FLOWS IN EXCEEDANCE OF 0.55 MGD ARE DIVERTED DOWNSTREAM OF THE COURSE SCREEN.

BASIN VOLUME DATA

BASIN VOLUME AT 911.0 WL = 1.1 MILLION GALLONS

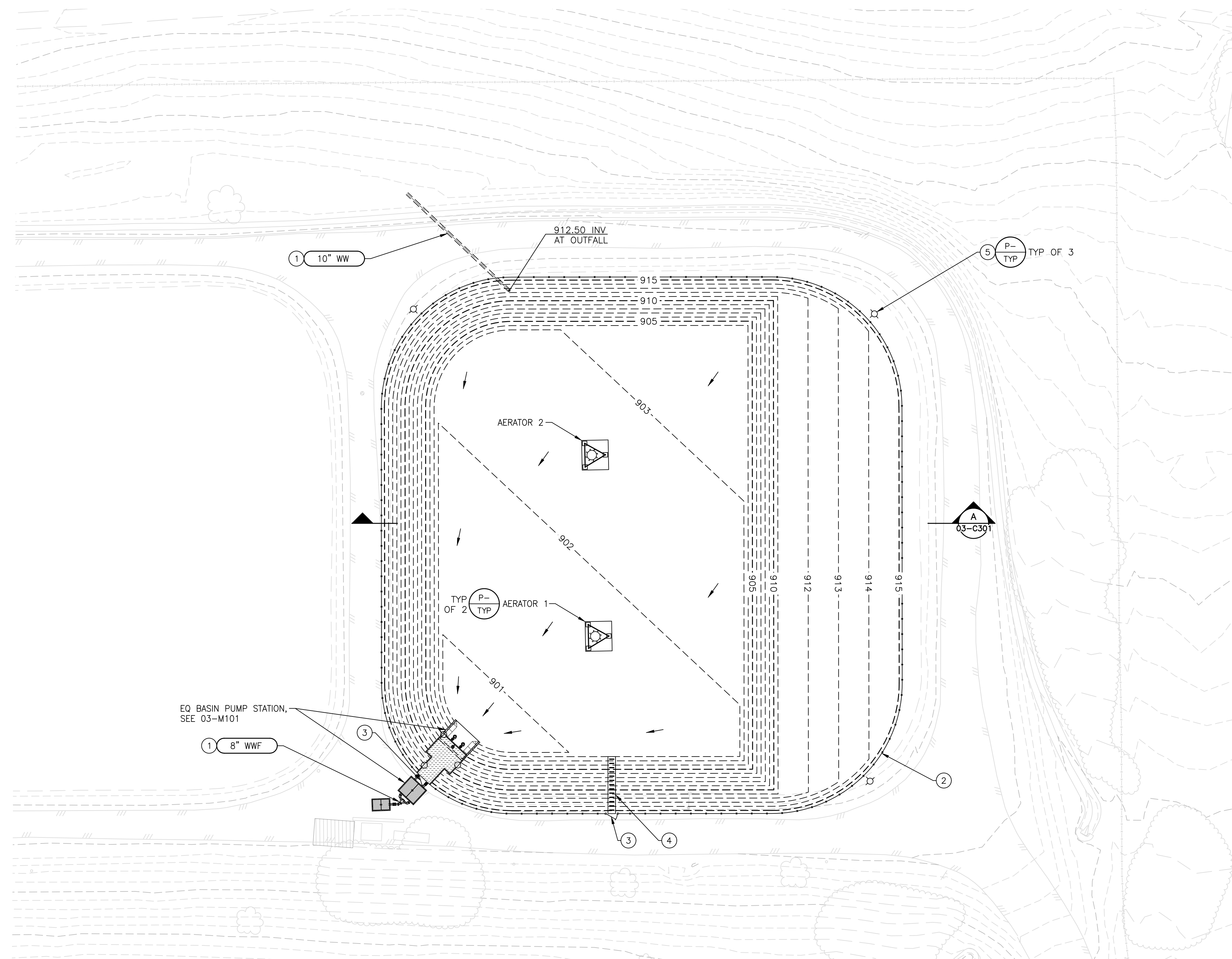

PLAN



Know what's below.
Call before you dig.

DRAFT - NOT FOR CONSTRUCTION

REV	DATE	BY	DESCRIPTION

WARNING

IF THIS BAR DOES NOT MEASURE 1" THEN DRAWING IS NOT TO SCALE.

DESIGNED	KCS
DRAWN	PMD
CHECKED	DSW
SCALE	1"=20'

PREPARED BY:

DATE



605 AEROVISTA PLACE, SUITE 201
PHONE: (805) 457-8833

SAN LUIS OBISPO, CA 93401
FAX: (805) 888-2764

HERITAGE RANCH COMMUNITY SERVICES DISTRICT
4870 HERITAGE ROAD
PASO ROBLES, CA 93446

APPROVED:

POSITION

DATE

WATER RESOURCE RECOVERY FACILITY UPGRADE

CIVIL

EQUALIZATION BASIN PLAN

DRAWING

03-C101

SHEET X OF X

PROJECT #

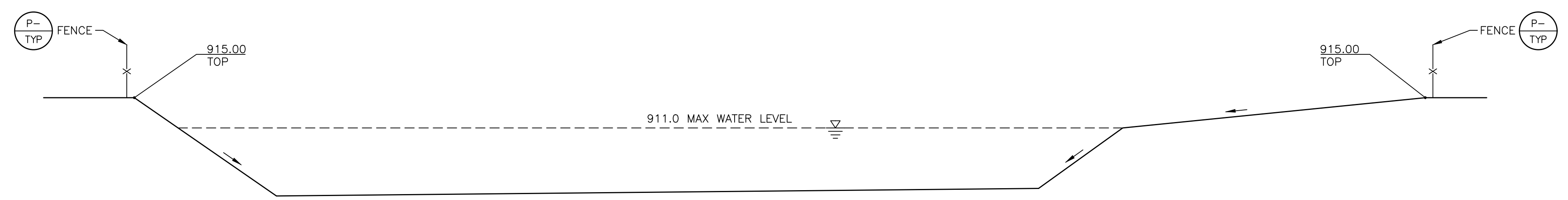

EQ BASIN SECTION
SCALE: 1"=10'

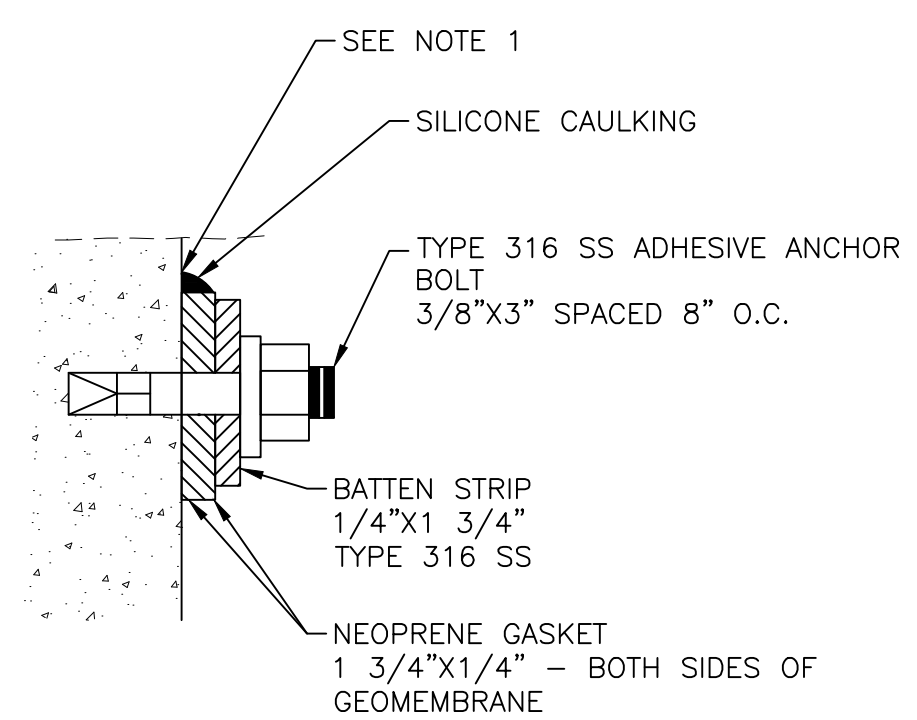

NOTES:
1. WHERE BONDING A GEOMEMBRANE TO CONCRETE OR MASONRY IS REQUIRED, THE CONCRETE SURFACE SHALL BE SMOOTH, CLEAN, DRY, AND FREE OF ANY SHARP PROTRUSIONS OR ROCK IN THE BACKFILL. GEOMEMBRANE TO CONCRETE SEALS SHALL BE ACCOMPLISHED WITH MECHANICAL ANCHORS (E.G. FASTENERS, TERMINATION BARS). CONTRACTOR SHALL PLACE APPROVED SEALANT BETWEEN THE GEOMEMBRANE AND THE CONCRETE SURFACE.

GEOMEMBRANE CONCRETE ATTACHMENT
N.T.S.

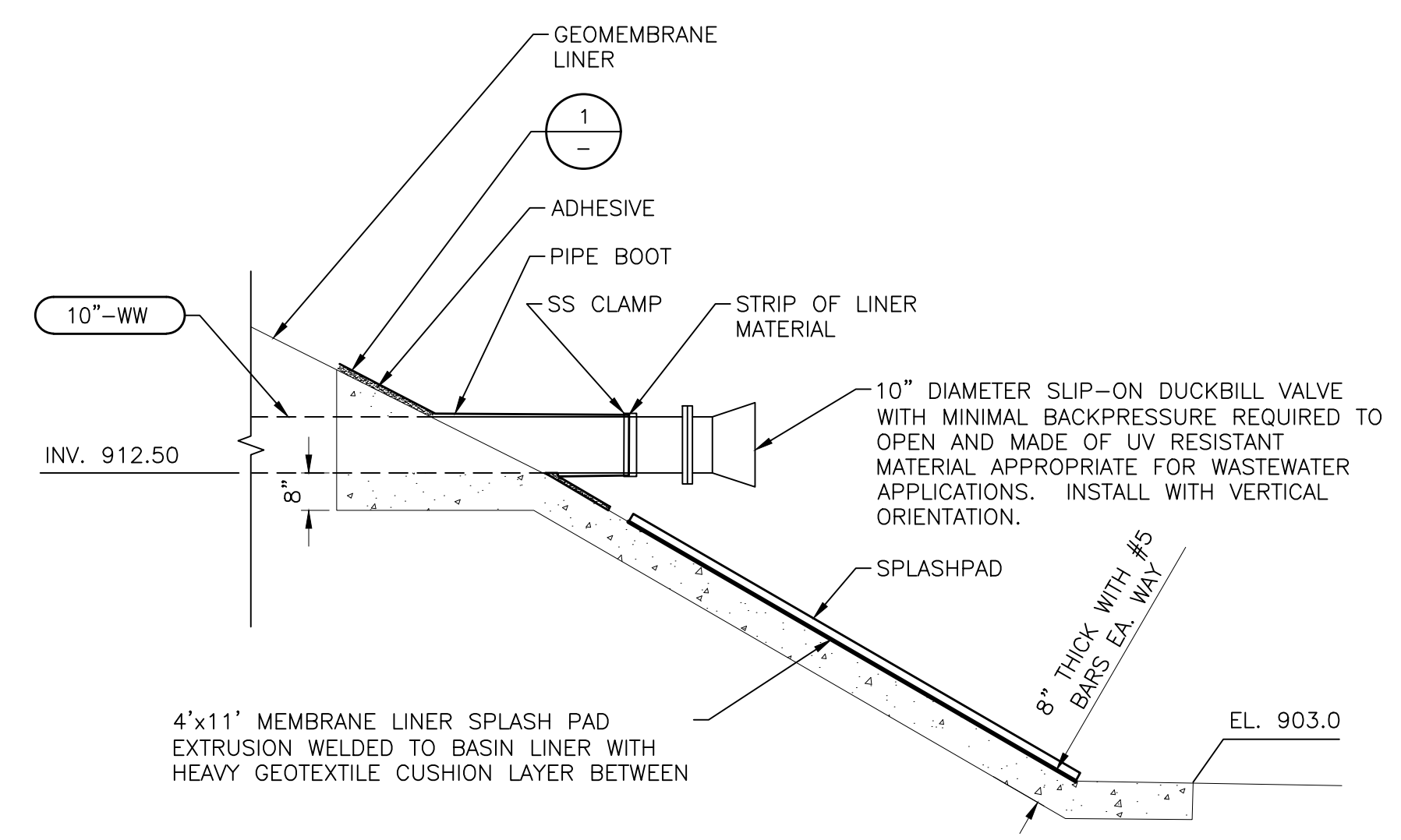

EQ BASIN INLET PIPE DETAIL
N.T.S.



Know what's below.
Call before you dig.

DRAFT - NOT FOR CONSTRUCTION

<p>WARNING</p> <p>IF THIS BAR DOES NOT MEASURE 1" THEN DRAWING IS NOT TO SCALE.</p>				<p>DESIGNED: KCS</p> <p>DRAWN: PMD</p> <p>CHECKED: DSW</p> <p>SCALE: AS NOTED</p>	<p>PREPARED BY:</p> <p>DATE:</p>		<p>805 AEROVISTA PLACE, SUITE 201 PHONE: (805) 457-8833</p> <p>SAN LUIS OBISPO, CA 93401 FAX: (805) 888-2764</p>	<p>HERITAGE RANCH COMMUNITY SERVICES DISTRICT 4870 HERITAGE ROAD PASO ROBLES, CA 93446</p> <p>APPROVED:</p> <p>POSITION: _____ DATE: _____</p>	<p>WATER RESOURCE RECOVERY FACILITY UPGRADE</p> <p>CIVIL</p> <p>EQUALIZATION BASIN SECTION</p>	<p>DRAWING</p> <p>03-C301</p> <p>SHEET X OF X</p> <p>PROJECT # _____</p>
---	--	--	--	---	----------------------------------	--	--	--	--	--

W:\3.0 Clients\Heritage Ranch Community Services District 1029\10090 WRF Upgrade Design\6.0 Working Files\CAD\1-SHEET FILES\C-HRCSO-WWTP - 03 EQ Basin.dwg 11/10/2023 4:19 PM Mary Harrington

W:\3.0 Clients\Heritage Ranch Community Services District\1029\10090 WRF Upgrade Design\6.0 Working Files\0-CAD\1-SHEET FILES\M-HRCSO-WWTP - 03 EQ PS.dwg 11/10/2023 4:41 PM Mary Harrington

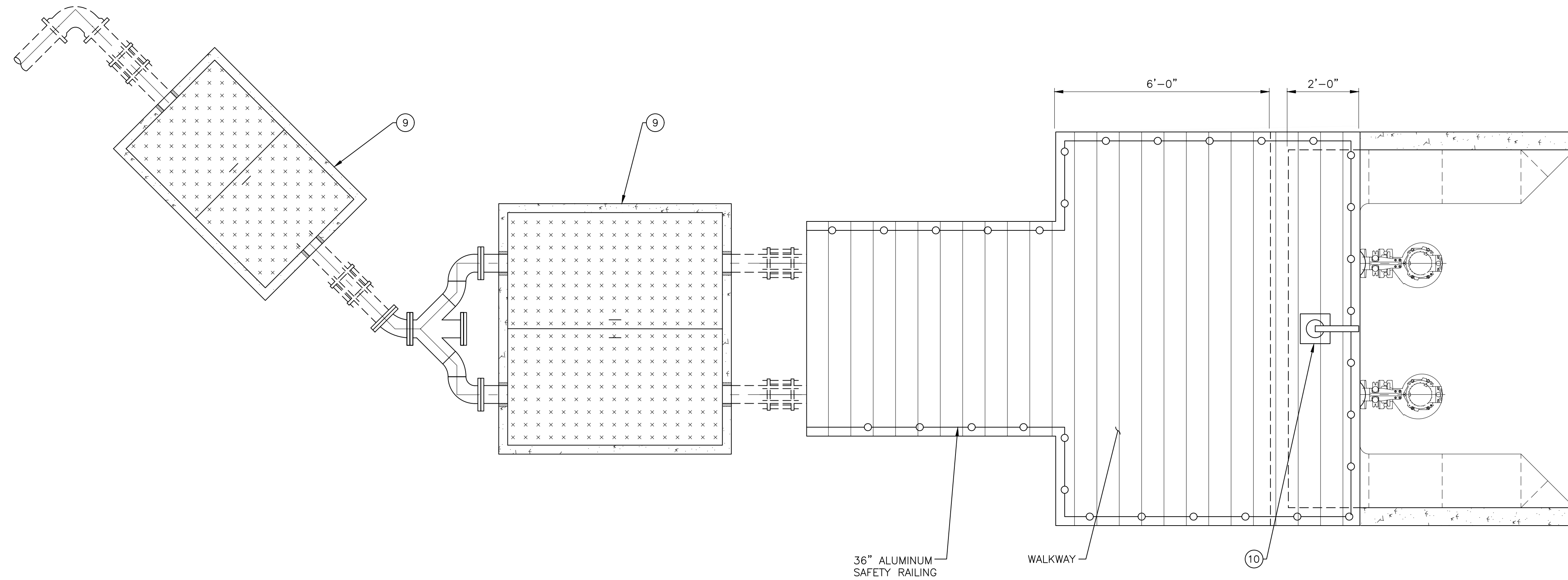

EQUALIZATION BASIN PUMP STATION TOP PLAN

SCALE: 1/2"=1'-0"

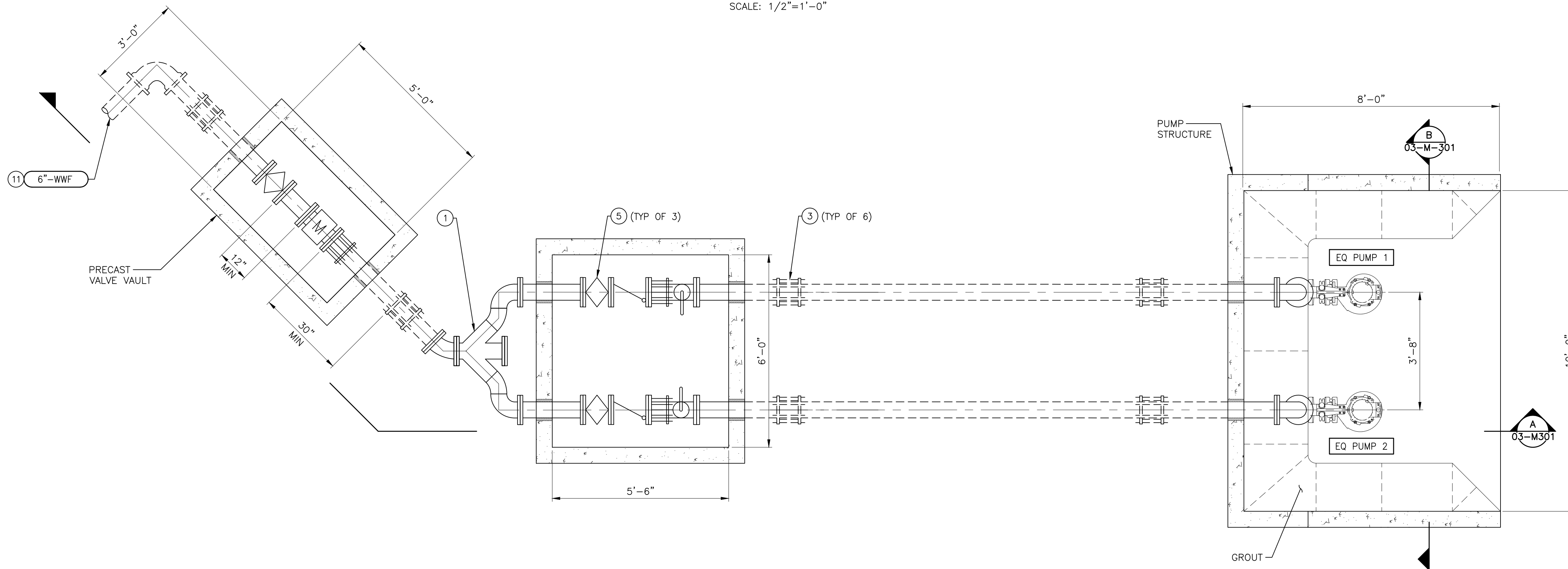

EQUALIZATION BASIN PUMP STATION BOTTOM PLAN

SCALE: 1/2"=1'-0"

SHEET KEY NOTES

- ① 6" DOUBLE WYE
- ② 1" COMBINATION AIR RELEASE VALVE
- ③ 6" FLEXIBLE COUPLING
- ④ 6" SWING CHECK VALVE
- ⑤ 6" PLUG VALVE
- ⑥ DISMANTLING JOINT
- ⑦ HANGING PIPE SUPPORTS
- ⑧ GEOMEMBRANE TO CONCRETE SEALS SHALL BE ACCOMPLISHED WITH MECHANICAL ANCHORS (E.G. FASTENERS, TERMINATION BARS)
- ⑨ PRECAST CONCRETE VAULT, H20 RATED, WITH SPRING LOADED DOUBLE LEAF HATCH
- ⑩ DAVIT CRANE, 500 LB MINIMUM
- ⑪ FOR CONTINUATION SEE YARD PIPING PLAN ON SHEET _

GENERAL NOTES

- 1. NOTES

DRAFT - NOT FOR CONSTRUCTION

REV	DATE	BY	DESCRIPTION

WARNING

IF THIS BAR DOES NOT MEASURE 1" THEN DRAWING IS NOT TO SCALE.

DESIGNED	KCS
DRAWN	PMD
CHECKED	DSW
SCALE	AS NOTED

PREPARED BY: _____ DATE: _____



HERITAGE RANCH COMMUNITY SERVICES DISTRICT
4870 HERITAGE ROAD
PASO ROBLES, CA 93446

805 AEROVISTA PLACE, SUITE 201 SAN LUIS OBISPO, CA 93401
PHONE: (805) 457-8833 FAX: (805) 888-2764

APPROVED: _____ POSITION: _____ DATE: _____

WATER RESOURCE RECOVERY FACILITY UPGRADE
MECHANICAL

EQUALIZATION BASIN PUMP STATION
PLAN AND SECTION

DRAWING
03-M101
SHEET X OF X
PROJECT # _____

W:\3.0 Clients\Heritage Ranch Community Services District\1029\10090 WRF Upgrade Design\6.0 Working Files\CAD\1-SHEET FILES\M-HRCSO-WWTP -- 03 EQ PS.dwg 11/10/2023 4:41 PM Mary Harrington

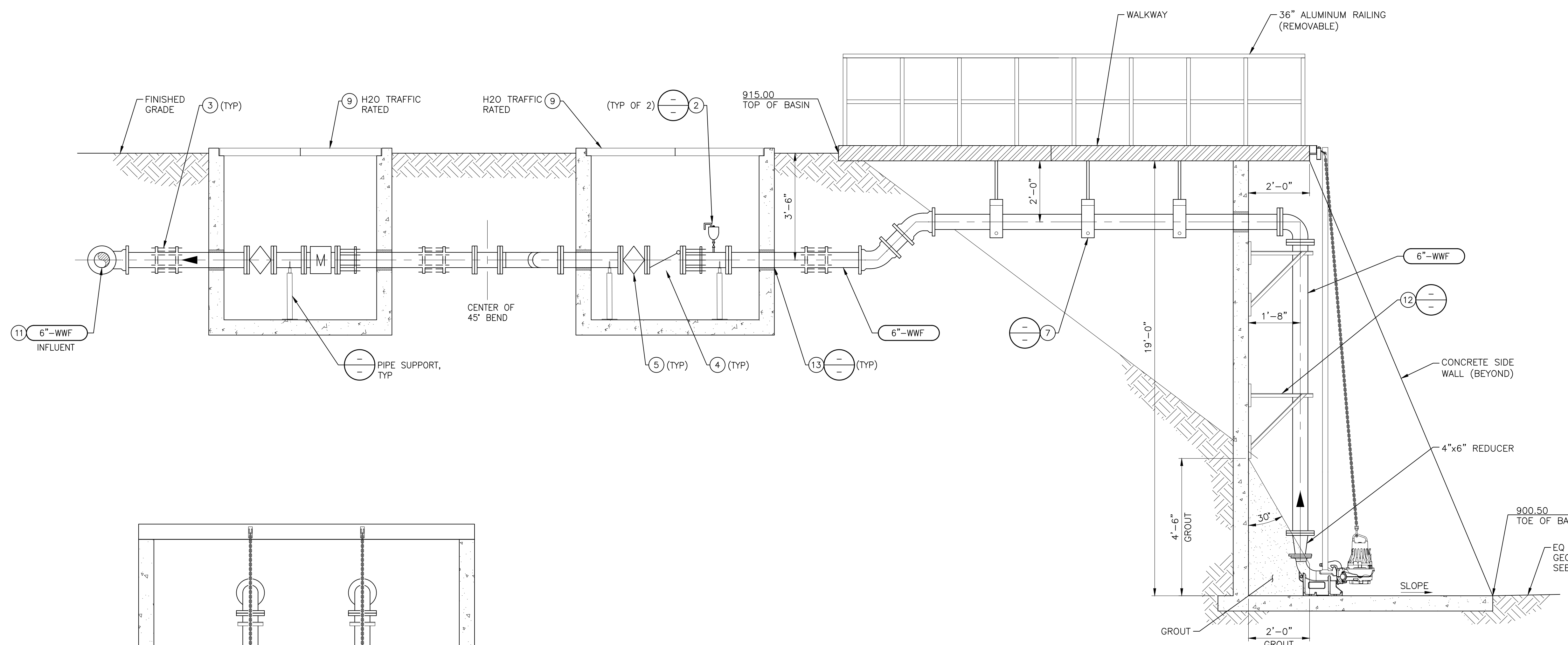

- SHEET KEY NOTES**
- ① 6" DOUBLE WYE
 - ② 1" COMBINATION AIR RELEASE VALVE
 - ③ 6" FLEXIBLE COUPLING
 - ④ 6" SWING CHECK VALVE
 - ⑤ 6" PLUG VALVE
 - ⑥ DISMANTLING JOINT
 - ⑦ HANGING PIPE SUPPORTS
 - ⑧ GEOMEMBRANE TO CONCRETE SEALS SHALL BE ACCOMPLISHED WITH MECHANICAL ANCHORS (E.G. FASTENERS, TERMINATION BARS) CONCRETE SURFACE SHALL BE SMOOTH, CLEAN, DRY, AND FREE OF ANY SHARP PROTRUSIONS OR ROCK IN THE BACKFILL. CONTRACTOR SHALL PLACE APPROVED SEALANT BETWEEN THE GEOMEMBRANE AND THE CONCRETE SURFACE
 - ⑨ PRECAST CONCRETE VAULT, H2O RATED, WITH SPRING LOADED DOUBLE LEAF HATCH
 - ⑩ DAVIT CRANE, 500 LB MINIMUM
 - ⑪ FOR CONTINUATION SEE YARD PIPING PLAN ON SHEET _
 - ⑫ VERTICAL PIPE SUPPORTS
 - ⑬ PIPE PENETRATION

EQUALIZATION BASIN PUMP STATION SECTION (A)
SCALE: 1/2"=1'-0"

GENERAL NOTES
1. NOTES

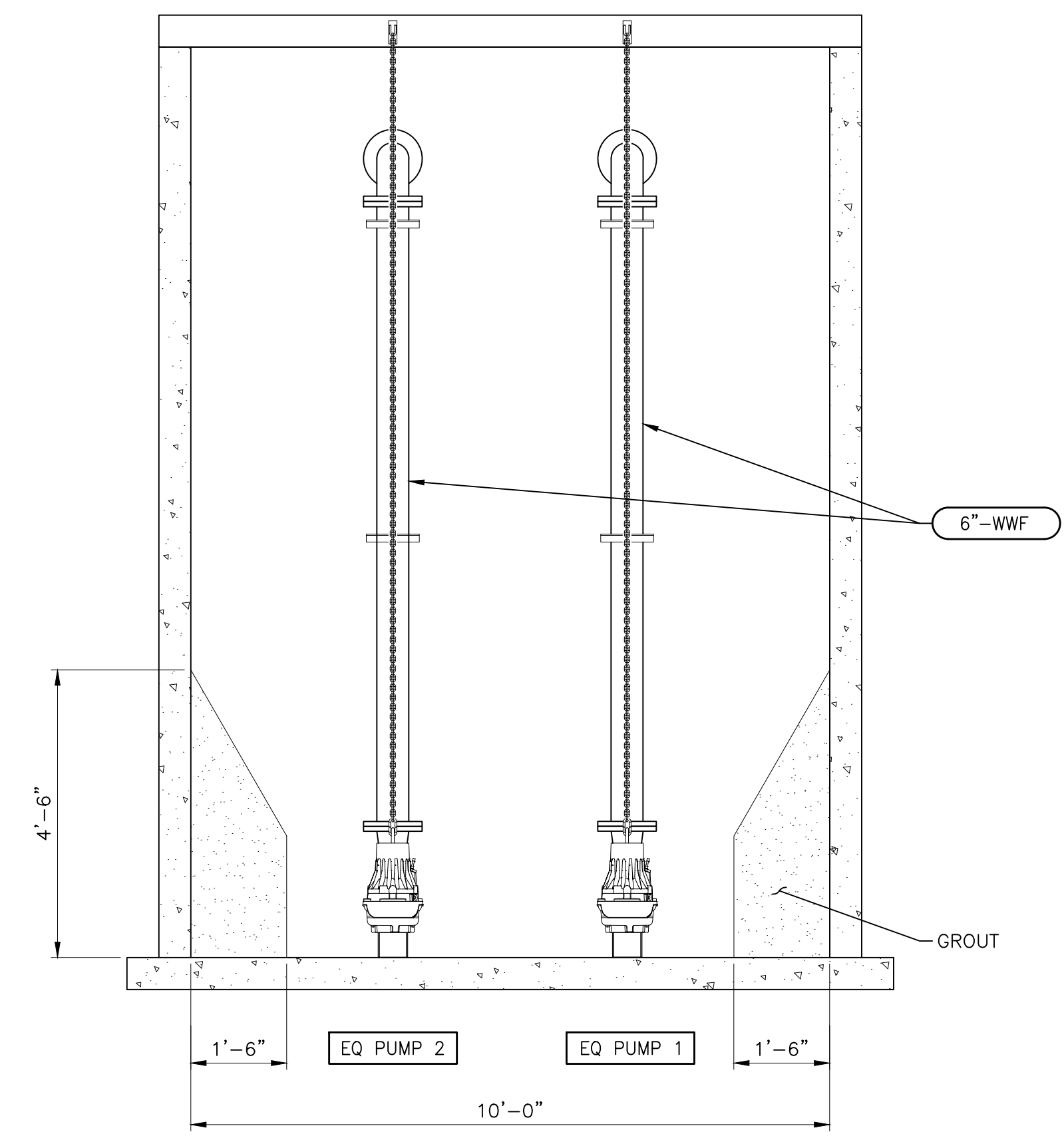

EQUALIZATION BASIN PUMP STATION SECTION (B)
SCALE: 1/2"=1'-0"

REV	DATE	BY	DESCRIPTION

WARNING
0 1/2 1
IF THIS BAR DOES NOT MEASURE 1" THEN DRAWING IS NOT TO SCALE.

DESIGNED: KCH
DRAWN: PMD
CHECKED: DSW
SCALE: 1/2"=1'-0"

PREPARED BY: _____
DATE: _____



HERITAGE RANCH COMMUNITY SERVICES DISTRICT
4870 HERITAGE ROAD
PASO ROBLES, CA 93446

APPROVED: _____
POSITION: _____ DATE: _____

WATER RESOURCE RECOVERY FACILITY UPGRADE
MECHANICAL
EQUALIZATION BASIN PUMP STATION SECTIONS

DRAWING
03-M301
SHEET X OF X
PROJECT # _____

DRAFT - NOT FOR CONSTRUCTION

W:\3.0 Clients\Heritage Ranch Community Services District\1029\10090 WRF Upgrade Design\6.0 Working Files\CAD\1-SHEET FILES\M-HRCSO-WWTP -- 05 Chem Strg.dwg 11/10/2023 3:01 PM Mary Harrington

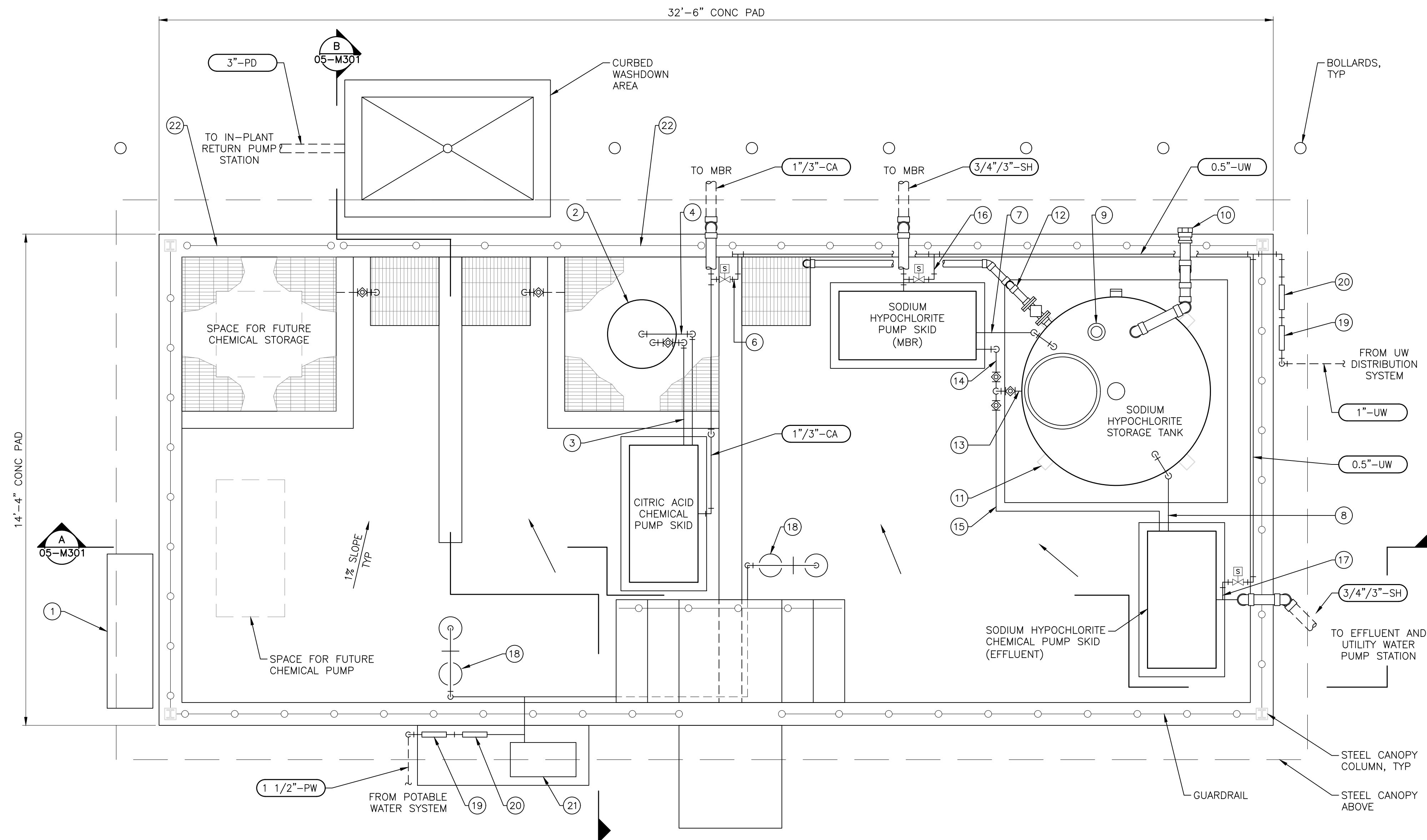

- SHEET KEY NOTES**
- 1 CHEMICAL STORAGE AREA ELECTRICAL CONTROL PANEL
 - 2 CITRIC ACID STORAGE DRUM
 - 3 CITRIC ACID PUMP SKID SUCTION LINE
 - 4 CITRIC ACID PUMP SKID VENT LINE
 - 5 CITRIC ACID SECONDARY CONTAINMENT DRAIN LINE
 - 6 CITRIC ACID PUMP SKID UW FLUSHING LINE
 - 7 SODIUM HYPOCHLORITE PUMP SKID (MBR) VENT LINE
 - 8 SODIUM HYPOCHLORITE PUMP SKID (EFFLUENT) VENT LINE
 - 9 STORAGE TANK LEVEL TRANSMITTER
 - 10 SODIUM HYPOCHLORITE BULK CHEMICAL QUICK-CONNECT TANK FILL WITH STRAINER
 - 11 STORAGE TANK ANCHORS, TYPICAL OF 4
 - 12 STORAGE TANK OVERFLOW AND DRAIN LINE
 - 13 SODIUM HYPOCHLORITE SUCTION LINE
 - 14 SODIUM HYPOCHLORITE PUMP SKID (MBR) SUCTION LINE
 - 15 SODIUM HYPOCHLORITE PUMP SKID (EFFLUENT) SUCTION LINE
 - 16 SODIUM HYPOCHLORITE PUMP SKID (MBR) UW FLUSHING LINE
 - 17 SODIUM HYPOCHLORITE PUMP SKID (EFFLUENT) UW FLUSHING LINE
 - 18 EMERGENCY EYE WASH AND SHOWER
 - 19 REDUCED PRESSURE BACKFLOW PREVENTER
 - 20 PRESSURE REDUCING STATION
 - 21 ELECTRIC WATER HEATER
 - 22 REMOVABLE GUARDRAIL FOR OFFLOADING TOTES AND DRUMS

CHEMICAL STORAGE AREA PLAN
SCALE: 1/2"=1'-0"

DRAFT - NOT FOR CONSTRUCTION

REV	DATE	BY	DESCRIPTION

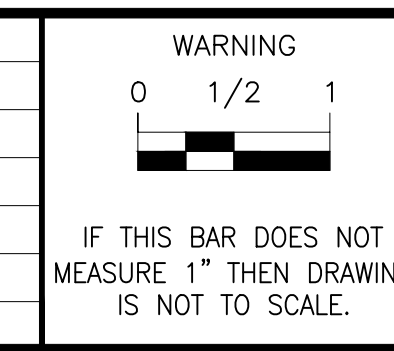

DESIGNED	MNR
DRAWN	MAH
CHECKED	DSW
SCALE	1/2"=1'-0"

PREPARED BY:
MATTHEW N. RODRIGUES
RCE No.: 84311

DATE



WSC

805 AEROVISTA PLACE, SUITE 201 SAN LUIS OBISPO, CA 93401
PHONE: (805) 457-8833 FAX: (805) 888-2764

HERITAGE RANCH COMMUNITY SERVICES DISTRICT
4870 HERITAGE ROAD
PASO ROBLES, CA 93446

APPROVED: _____ POSITION _____ DATE _____

WATER RESOURCE RECOVERY FACILITY UPGRADE
MECHANICAL

CHEMICAL STORAGE AREA PLAN

DRAWING
05-M101

SHEET X OF X
PROJECT # _____

W:\3.0 Clients\Heritage Ranch Community Services District\1029\10090 WRF Upgrade Design\6.0 Working Files\0-CAD\1-SHEET FILES\M-HRCSO-WWTP - 05 Chem Strg.dwg 11/10/2023 3:01 PM Mary Harrington

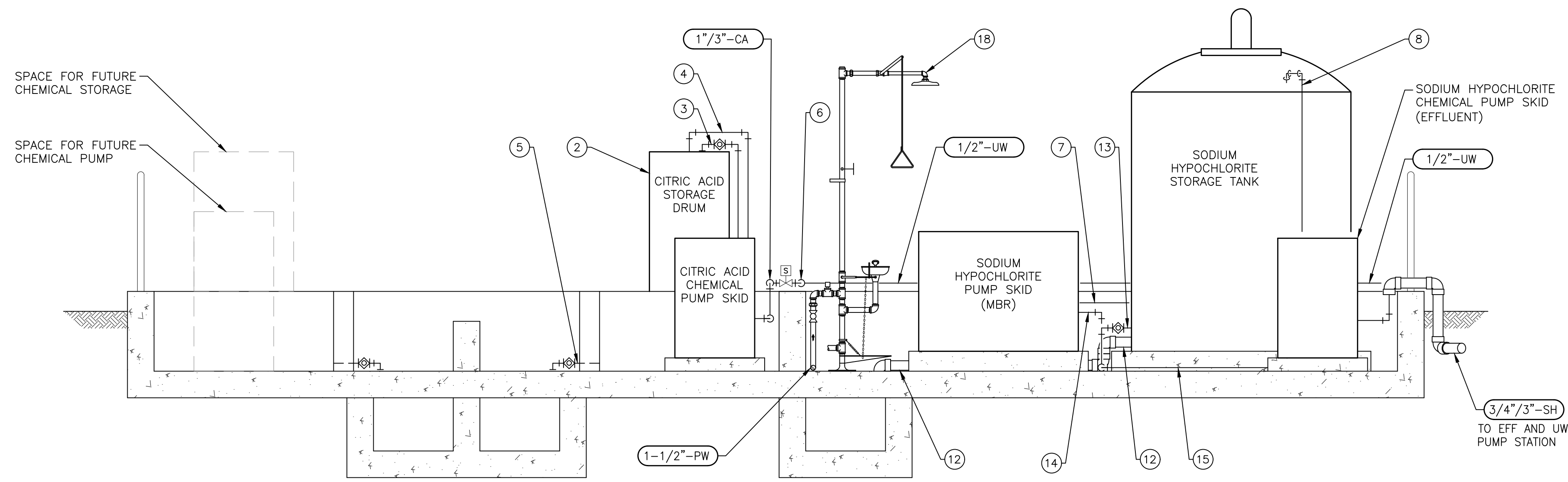

CHEMICAL STORAGE AREA SECTION A
SCALE: 1/2"=1'-0"

NOTE:
UTILITY WATER DISTRIBUTION PIPELINE REDUCED PRESSURE BACKFLOW PREVENTER AND PRESSURE REDUCING STATION NOT SHOWN.

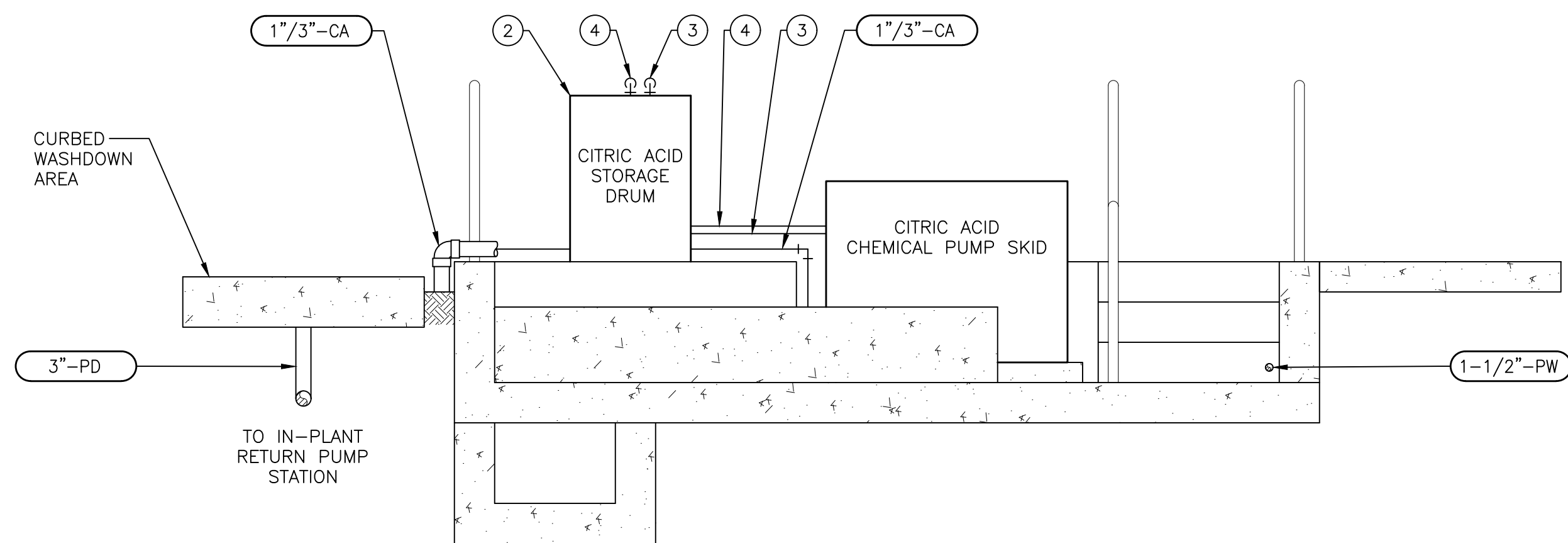

CHEMICAL STORAGE AREA SECTION B
SCALE: 1/2"=1'-0"

NOTE:
EQUIPMENT AND PIPING IN SODIUM HYPOCHLORITE CHEMICAL STORAGE AREA NOT SHOWN FOR CLARITY.

SHEET KEY NOTES

- ① CHEMICAL STORAGE AREA ELECTRICAL CONTROL PANEL
- ② CITRIC ACID STORAGE DRUM
- ③ CITRIC ACID PUMP SKID SUCTION LINE
- ④ CITRIC ACID PUMP SKID VENT LINE
- ⑤ CITRIC ACID SECONDARY CONTAINMENT DRAIN LINE
- ⑥ CITRIC ACID PUMP SKID UW FLUSHING LINE
- ⑦ SODIUM HYPOCHLORITE PUMP SKID (MBR) VENT LINE
- ⑧ SODIUM HYPOCHLORITE PUMP SKID (EFFLUENT) VENT LINE
- ⑨ STORAGE TANK LEVEL TRANSMITTER
- ⑩ SODIUM HYPOCHLORITE BULK CHEMICAL QUICK-CONNECT TANK FILL WITH STRAINER
- ⑪ STORAGE TANK ANCHORS, TYPICAL OF 4
- ⑫ STORAGE TANK OVERFLOW AND DRAIN LINE
- ⑬ SODIUM HYPOCHLORITE SUCTION LINE
- ⑭ SODIUM HYPOCHLORITE PUMP SKID (MBR) SUCTION LINE
- ⑮ SODIUM HYPOCHLORITE PUMP SKID (EFFLUENT) SUCTION LINE
- ⑯ SODIUM HYPOCHLORITE PUMP SKID (MBR) UW FLUSHING LINE
- ⑰ SODIUM HYPOCHLORITE PUMP SKID (EFFLUENT) UW FLUSHING LINE
- ⑱ EMERGENCY EYE WASH AND SHOWER
- ⑲ REDUCED PRESSURE BACKFLOW PREVENTER
- ⑳ PRESSURE REDUCING STATION
- ㉑ ELECTRIC WATER HEATER
- ㉒ REMOVABLE GUARDRAIL FOR OFFLOADING TOTES AND DRUMS

GENERAL NOTES

1. METAL CANOPY SYSTEM NOT SHOWN. REFER TO STRUCTURAL SHEETS.
2. RAILING NOT SHOWN IN ALL LOCATIONS FOR CLARITY.

DRAFT - NOT FOR CONSTRUCTION

REV	DATE	BY	DESCRIPTION

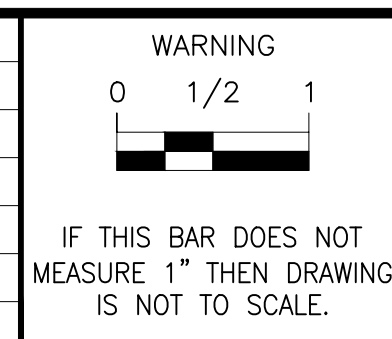

DESIGNED	KCH
DRAWN	MAH
CHECKED	DSW
SCALE	1/2"=1'-0"

PREPARED BY:
MATTHEW N. RODRIGUES
RCE No.: 84311

DATE

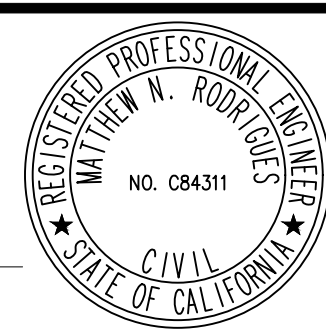

HERITAGE RANCH COMMUNITY SERVICES DISTRICT
4870 HERITAGE ROAD
PASO ROBLES, CA 93446

605 AEROVISTA PLACE, SUITE 201 SAN LUIS OBISPO, CA 93401
PHONE: (805) 457-8833 FAX: (805) 888-2764

APPROVED: _____ POSITION _____ DATE _____

WATER RESOURCE RECOVERY FACILITY UPGRADE
MECHANICAL

CHEMICAL STORAGE AREA SECTIONS

DRAWING
05-M301
SHEET X OF X
PROJECT #

W:\3.0 Clients\Heritage Ranch Community Services District\1029\10090 WRF Upgrade Design\6.0 Working Files\0-CAD\1-SHEET FILES\M-HRCSO-WWTP - 06 Dwt.dwg 10/17/2023 2:51 PM Mary Harrington

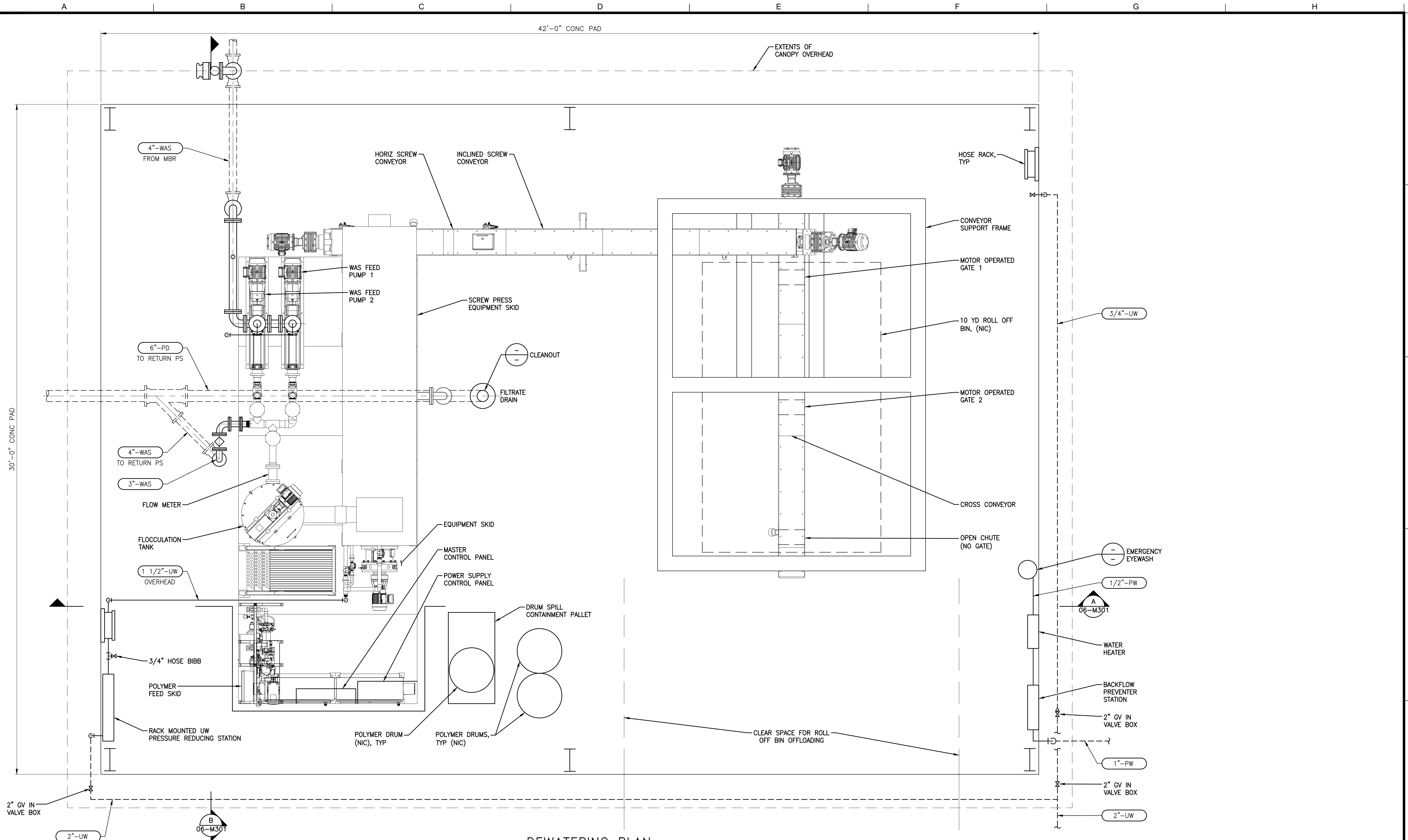

DEWATERING PLAN
SCALE: 1/2"=1'-0"

DRAFT - NOT FOR CONSTRUCTION

REV	DATE	BY	DESCRIPTION

WARNING

IF THIS BAR DOES NOT MEASURE 1" THEN DRAWING IS NOT TO SCALE.

DESIGNED	MNR
DRAWN	MAH
CHECKED	DSW
SCALE	1/2"=1'-0"

PREPARED BY:
MATTHEW N. RODRIGUES
RCE No.: 84311

DATE



WSC

805 AEROVISTA PLACE, SUITE 201
PHONE: (805) 457-8833

SAN LUIS OBISPO, CA 93401
FAX: (805) 888-2764

HERITAGE RANCH COMMUNITY SERVICES DISTRICT
4870 HERITAGE ROAD
PASO ROBLES, CA 93446

APPROVED: _____ POSITION _____ DATE _____

WATER RESOURCE RECOVERY FACILITY UPGRADE
MECHANICAL

DEWATERING PLAN

DRAWING
06-M101
SHEET X OF X
PROJECT # _____

W:\3.0 Clients\Heritage Ranch Community Services District\1029\10090 WRF Upgrade Design\6.0 Working Files\0-CAD\1-SHEET FILES\M-HRCSO-WWTP - 06 Dwt.dwg 10/17/2023 2:51 PM Mary Harrington

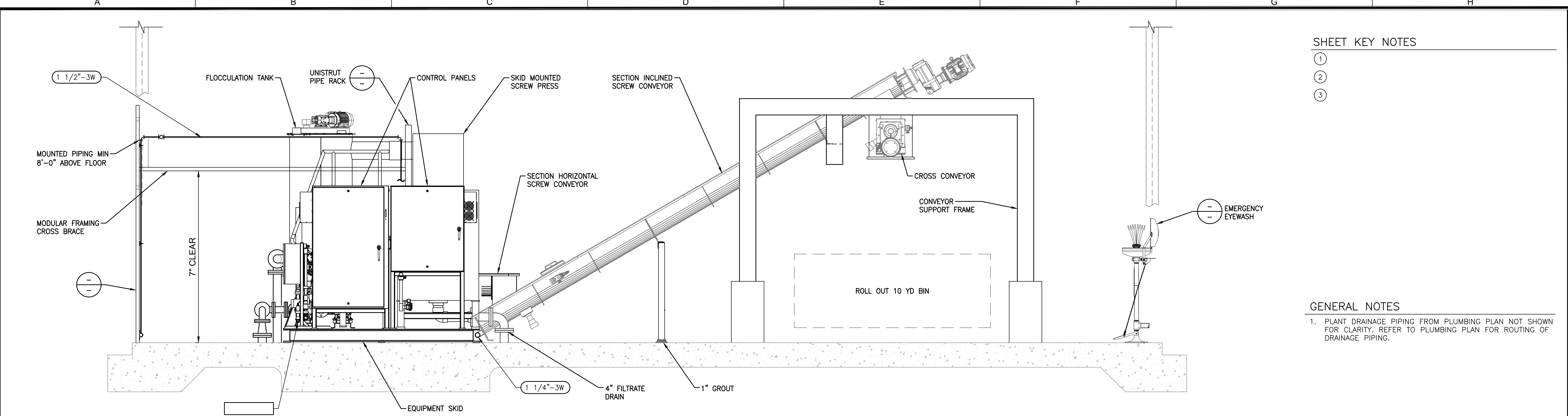

- SHEET KEY NOTES**
- ①
 - ②
 - ③

GENERAL NOTES

1. PLANT DRAINAGE PIPING FROM PLUMBING PLAN NOT SHOWN FOR CLARITY. REFER TO PLUMBING PLAN FOR ROUTING OF DRAINAGE PIPING.

DEWATERING SECTION A
SCALE: 1/2"=1'-0"

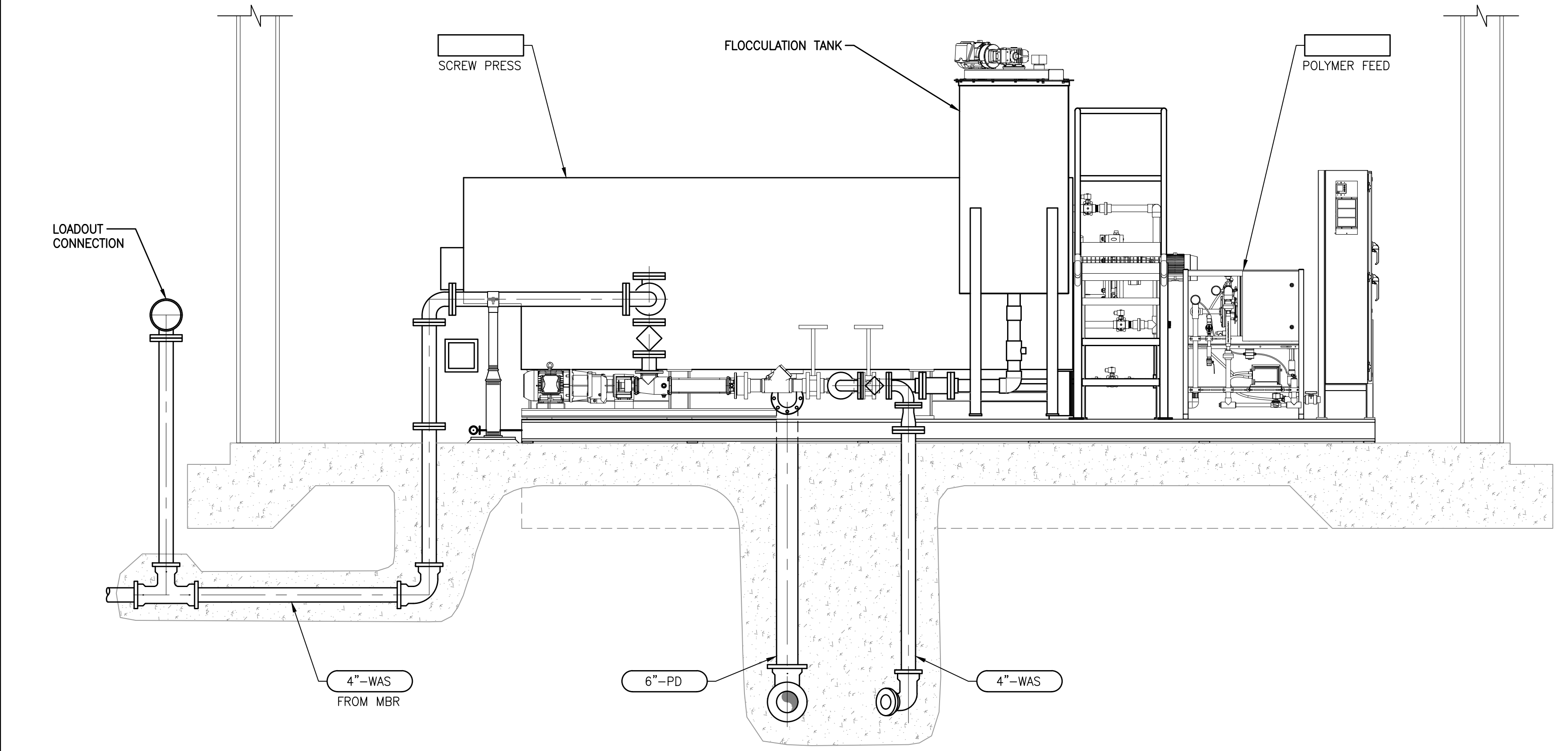

DEWATERING SECTION B
SCALE: 1/2"=1'-0"

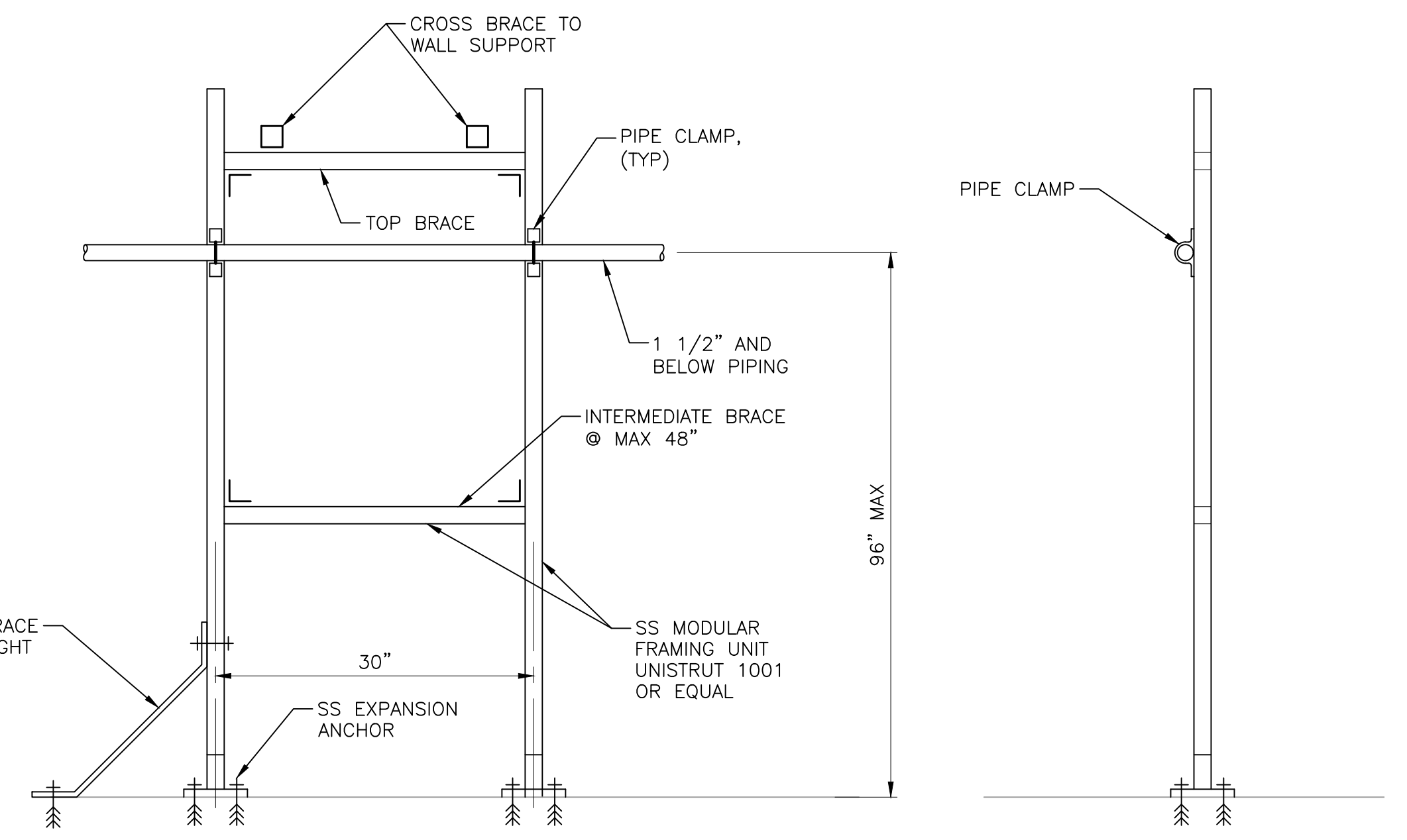

FRONT ELEVATION **SIDE ELEVATION**

MODULAR FRAMING PIPE RACK DETAIL X
SCALE: 1"=1'-0"

DRAFT - NOT FOR CONSTRUCTION

REV	DATE	BY	DESCRIPTION

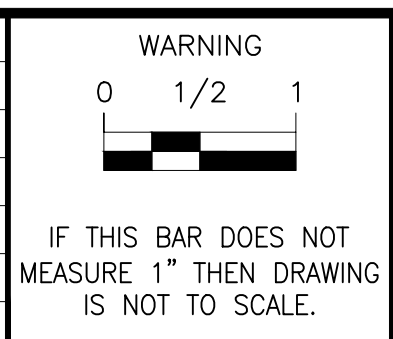

DESIGNED: MNR
DRAWN: MAH
CHECKED: DSW
SCALE: 1/2"=1'-0"

PREPARED BY:
MATTHEW N. RODRIGUES
RCE No.: 84311



WSC
605 AEROVISTA PLACE, SUITE 201 SAN LUIS OBISPO, CA 93401
PHONE: (805) 457-8833 FAX: (805) 888-2764

HERITAGE RANCH COMMUNITY SERVICES DISTRICT
4870 HERITAGE ROAD
PASO ROBLES, CA 93446

APPROVED: _____ POSITION _____ DATE _____

WATER RESOURCE RECOVERY FACILITY UPGRADE
MECHANICAL

DEWATERING SECTIONS

DRAWING
06-M301
SHEET X OF X
PROJECT # _____

SHEET KEY NOTES

- 1 SAMPLE TAP
- 2 HIGH PRESSURE SWITCH
- 3 PRESSURE INDICATING TRANSMITTER
- 4 EFFLUENT AND UTILITY WATER PUMP STATION CONTROL PANEL
- 5 PUMP STATION QUICK CONNECT BYPASS CONNECTION
- 6 SODIUM HYPOCHLORITE DOSING POINT
- 7 BLIND FLANGE CONNECTION FOR FUTURE RECYCLED WATER PIPING
- 8 DOUBLE-LEAF, SPRING LOADED, ALUMINUM CHECKER PLATE WITH STAINLESS STEEL HARDWARE, POSITIVE-LATCH OPENERS, AND INSIDE GRAB RAILS. MINIMUM OF 36" x 36"

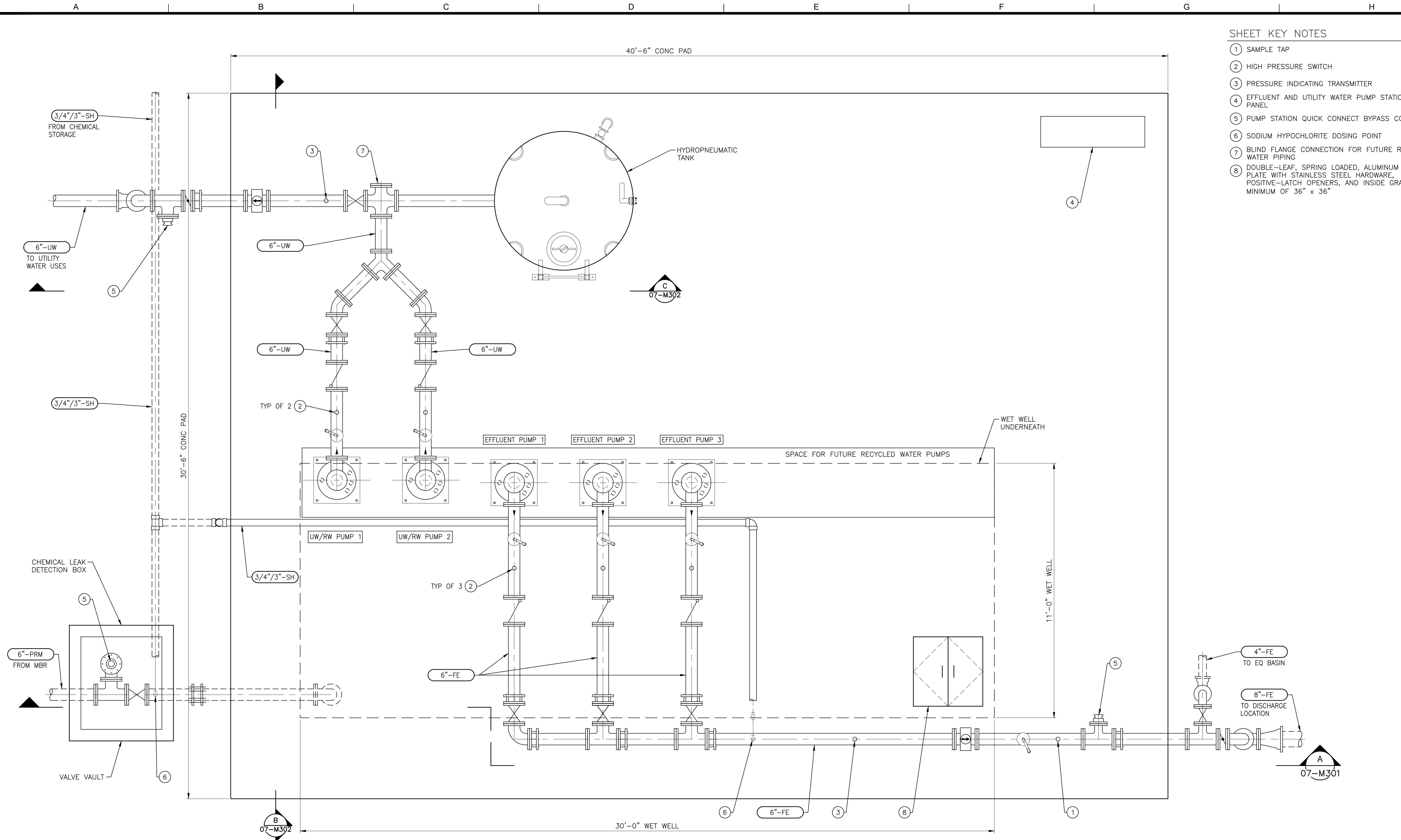

EFFLUENT AND UTILITY WATER PUMP STATION PLAN

SCALE: 1/2"=1'-0"

DRAFT - NOT FOR CONSTRUCTION

W:\3.0 Clients\Heritage Ranch Community Services District\1029\10090 WRF Upgrade Design\6.0 Working Files\0-CAD\1-SHEET FILES\M-HRCSO-WWTP - 07 EFF PS.dwg 11/10/2023 10:45 AM Mary Harrington

REV	DATE	BY	DESCRIPTION

WARNING

IF THIS BAR DOES NOT MEASURE 1" THEN DRAWING IS NOT TO SCALE.

DESIGNED MNR
 DRAWN MAH
 CHECKED DSW
 SCALE 1/2"=1'-0"

PREPARED BY:
 MATTHEW N. RODRIGUES
 RCE No.: 84311

DATE

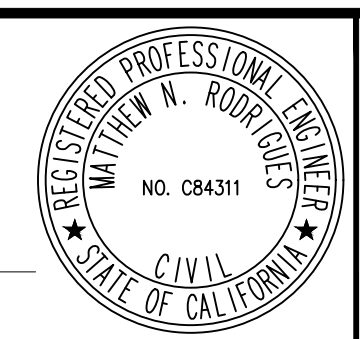

HERITAGE RANCH COMMUNITY SERVICES DISTRICT
 4870 HERITAGE ROAD
 PASO ROBLES, CA 93446

805 AEROVISTA PLACE, SUITE 201 SAN LUIS OBISPO, CA 93401
 PHONE: (805) 457-8833 FAX: (805) 888-2764

APPROVED: _____ POSITION _____ DATE _____

WATER RESOURCE RECOVERY FACILITY UPGRADE
 MECHANICAL
 EFFLUENT AND UTILITY WATER PUMP STATION PLAN

DRAWING
 07-M101
 SHEET X OF X
 PROJECT # _____

W:\3.0 Clients\Heritage Ranch Community Services District\1029\10090 WRF Upgrade Design\6.0 Working Files\0-CAD\1-SHEET FILES\M-HRCSO-WWTP -- 07 EFF PS.dwg 11/10/2023 10:45 AM Mary Harrington

SHEET KEY NOTES

- ① SAMPLE TAP
- ② HIGH PRESSURE SWITCH
- ③ PRESSURE INDICATING TRANSMITTER
- ④ EFFLUENT AND UTILITY WATER PUMP STATION CONTROL PANEL
- ⑤ PUMP STATION QUICK CONNECT BYPASS CONNECTION
- ⑥ SODIUM HYPOCHLORITE DOSING POINT
- ⑧ DOUBLE-LEAF, SPRING LOADED, ALUMINUM CHECKER PLATE WITH STAINLESS STEEL HARDWARE, POSITIVE-LATCH OPENERS, AND INSIDE GRAB RAILS. MINIMUM OF 36" x 36"

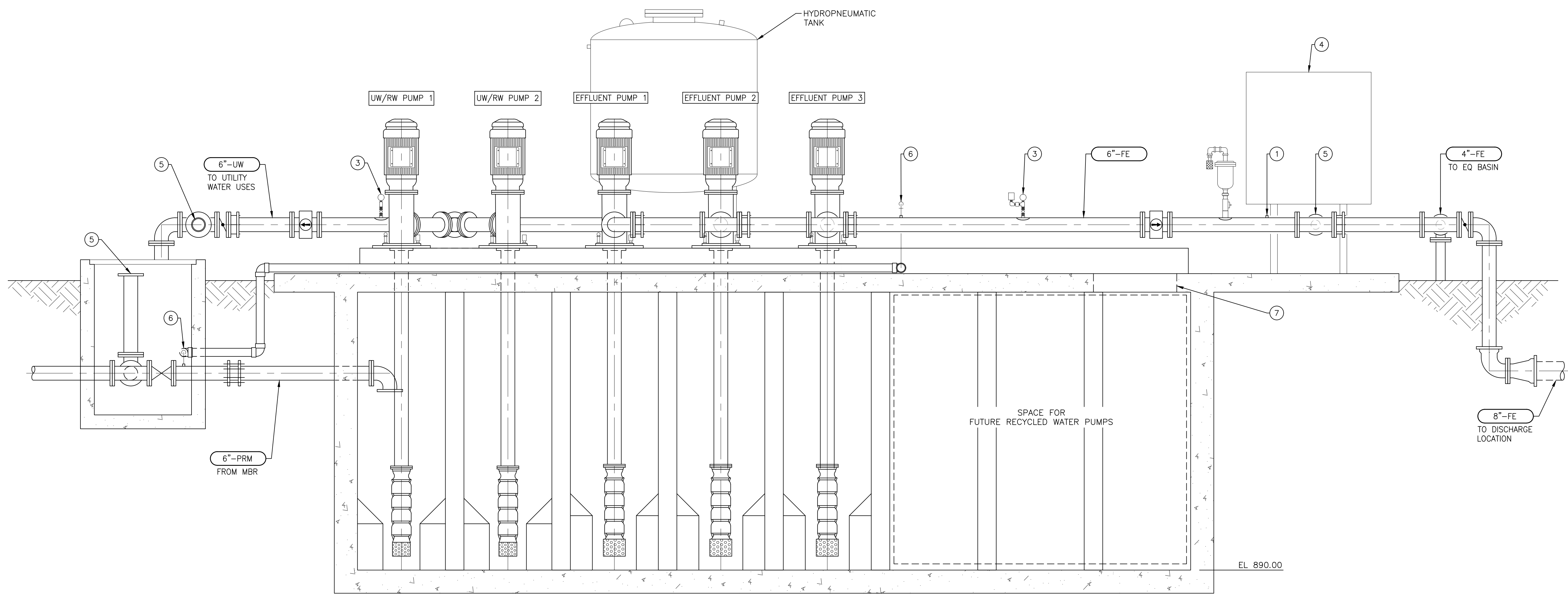

EFFLUENT AND UTILITY WATER PUMP STATION SECTION A
 SCALE: 1/2"=1'-0"

DRAFT - NOT FOR CONSTRUCTION

REV	DATE	BY	DESCRIPTION

WARNING

0 1/2 1

IF THIS BAR DOES NOT MEASURE 1" THEN DRAWING IS NOT TO SCALE.

DESIGNED	KCH
DRAWN	MAH
CHECKED	DSW
SCALE	1/2"=1'-0"

PREPARED BY:
 MATTHEW N. RODRIGUES
 RCE No.: 84311

DATE

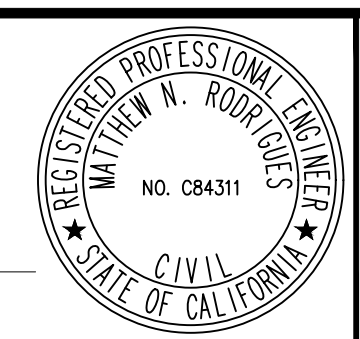

WSC

805 AEROVISTA PLACE, SUITE 201 SAN LUIS OBISPO, CA 93401
 PHONE: (805) 457-8833 FAX: (805) 888-2764

HERITAGE RANCH COMMUNITY SERVICES DISTRICT
 4870 HERITAGE ROAD
 PASO ROBLES, CA 93446

APPROVED: _____ POSITION _____ DATE _____

WATER RESOURCE RECOVERY FACILITY UPGRADE
 MECHANICAL

**EFFLUENT AND UTILITY WATER
 PUMP STATION SECTION**

DRAWING
07-M301
 SHEET X OF X
 PROJECT # _____

W:\3.0 Clients\Heritage Ranch Community Services District\1029\10090 WRF Upgrade Design\6.0 Working Files\0-CAD\1-SHEET FILES\M-HRCSO-WWTP -- 07 EFF PS.dwg 11/10/2023 10:45 AM Mary Harrington

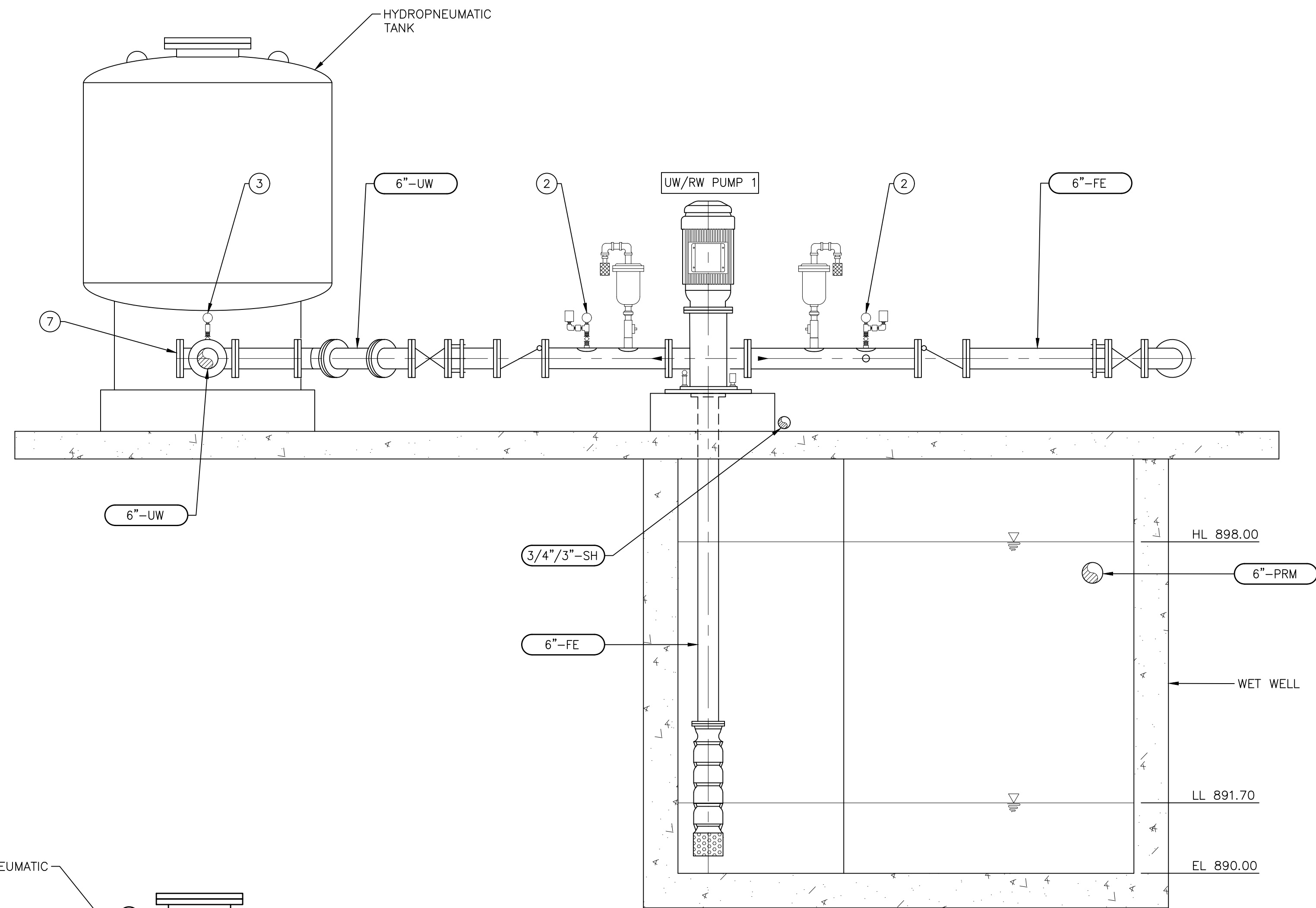

- SHEET KEY NOTES**
- ② HIGH PRESSURE SWITCH
 - ③ PRESSURE INDICATING TRANSMITTER
 - ⑤ PUMP STATION QUICK CONNECT BYPASS CONNECTION
 - ⑦ BLIND FLANGE CONNECTION FOR FUTURE RECYCLED WATER PIPING

GENERAL NOTES

- EFFLUENT PUMP NOT SHOWN FOR CLARITY.

EFFLUENT AND UTILITY WATER PUMP STATION SECTION B
SCALE: 1/2"=1'-0"

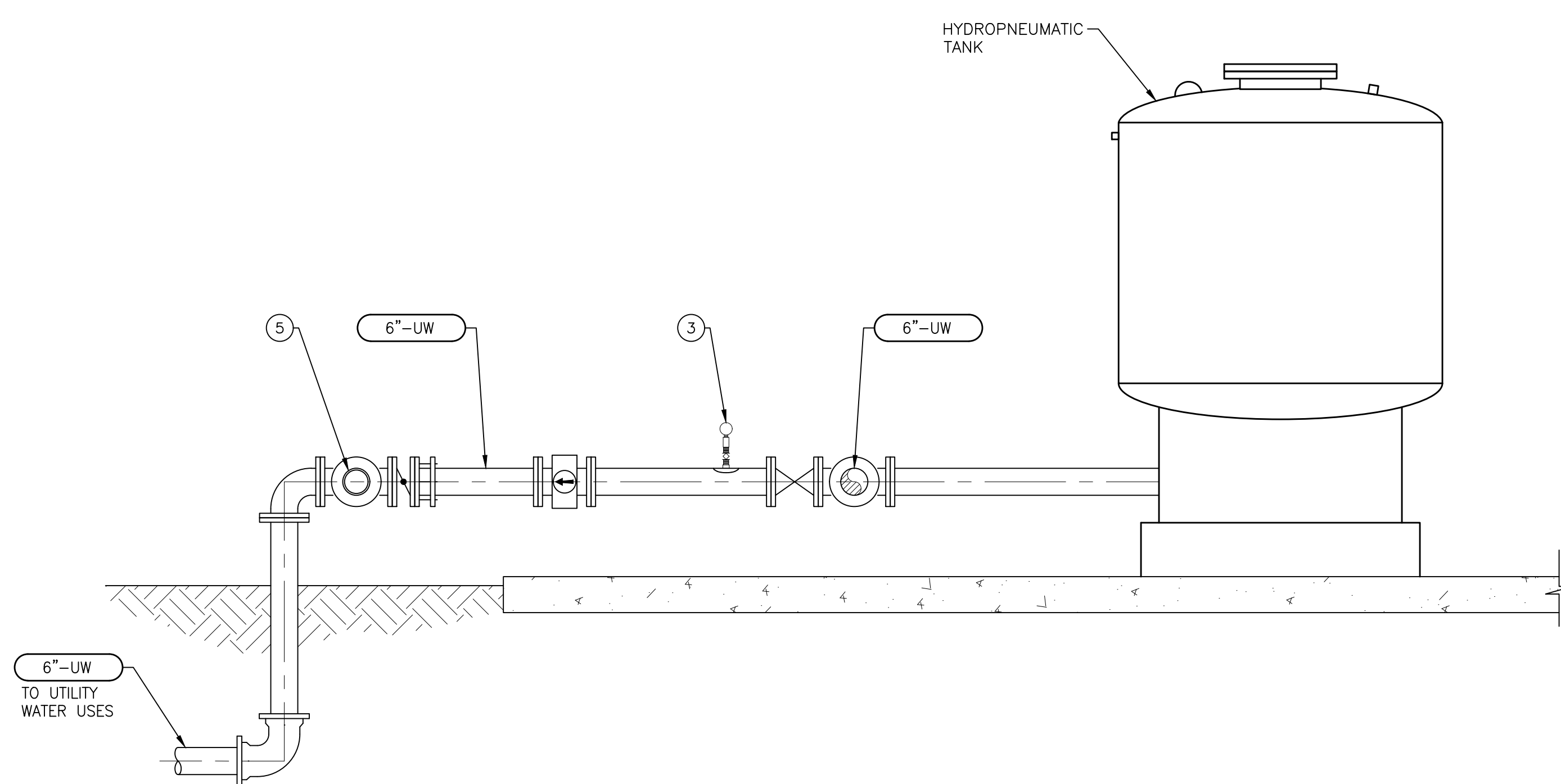

EFFLUENT AND UTILITY WATER PUMP STATION SECTION C
SCALE: 1/2"=1'-0"

DRAFT - NOT FOR CONSTRUCTION

REV	DATE	BY	DESCRIPTION

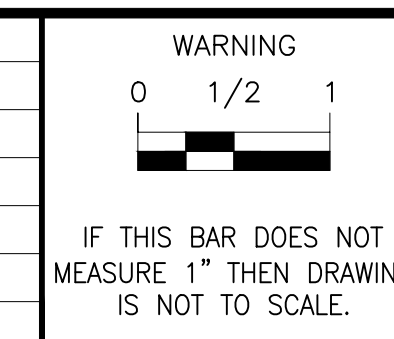

DESIGNED: KCH
 DRAWN: MAH
 CHECKED: DSW
 SCALE: 1/2"=1'-0"

PREPARED BY:
 MATTHEW N. RODRIGUES
 RCE No.: 84311

DATE: _____

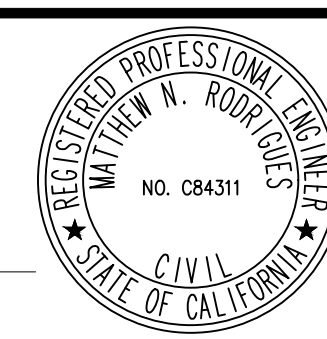

HERITAGE RANCH COMMUNITY SERVICES DISTRICT
 4870 HERITAGE ROAD
 PASO ROBLES, CA 93446

APPROVED: _____
 _____ POSITION DATE

WATER RESOURCE RECOVERY FACILITY UPGRADE
 MECHANICAL

EFFLUENT AND UTILITY WATER PUMP STATION SECTIONS

DRAWING
07-M302
 SHEET X OF X
 PROJECT # _____

ABBREVIATIONS	
A	AMPERES
AC	ALTERNATING CURRENT
AFF	ABOVE FINISHED FLOOR
AICS	AMPERES INTERRUPTING CAPACITY, SYMMETRICAL
AWG	AMERICAN WIRE GAUGE
BC	BARE COPPER
C	CONDUIT
CB	CIRCUIT BREAKER
CO	CONDUIT ONLY
CKT	CIRCUIT
CPT	CONTROL POWER TRANSFORMER
CT	CURRENT TRANSFORMER
DP	DEEP
DC	DIRECT CURRENT
DISC	DISCONNECT
DWG	DRAWING
E	EXISTING
ELEV	ELEVATION
G, GND	GROUND
GFCI	GROUND FAULT CURRENT INTERRUPTING
GRS	GALVANIZED RIGID STEEL
HDG	HOT DIPPED GALVANIZED
HH	HANDHOLE
HOA	HAND OFF AUTOMATIC
HP	HORSEPOWER
HPS	HIGH PRESSURE SODIUM
HR	HOUR
Hz	HERTZ
JB	JUNCTION BOX
KVA	KILOVOLT AMPERES
KW	KILOWATT
L	LONG
LA	LIGHTING ARRESTOR
LTG	LIGHTING
MT'D	MOUNTED
MA	MILLIAMPERE
MCC	MOTOR CONTROL CENTER
MCB	MAIN CIRCUIT BREAKER
MIN	MINIMUM
N	NEUTRAL
NC	NORMAL CLOSED
NO	NORMAL OPEN
NTS	NOT TO SCALE
O/L'S	OVERLOADS
P	POLE
PB	PULL BOX, PUSH BUTTON
PH, Ø	PHASE
PLC	PROGRAMMABLE LOGIC CONTROLLER
PQM	POWER QUALITY METER
PS	PRESSURE SWITCH
PT	POTENTIAL TRANSFORMER
PVC	POLYVINYL CHLORIDE
RECP	RECEPTACLE
RGS	RIGID STEEL CONDUIT
RVSS	REDUCED VOLTAGE SOLID STATE
SMUD	SACRAMENTO MUNICIPAL UTILITY DISTRICT
SW	SWITCH
TB	TERMINAL BOARD
TEL. CO.	TELEPHONE COMPANY
TWSP	TWISTED SHIELDED PAIR
TYP	TYPICAL
UON	UNLESS OTHERWISE NOTED
UG	UNDERGROUND
V	VOLT
W	WIRE, WIDE
W/	WITH
WP	WEATHERPROOF
XFMR	TRANSFORMER

ELECTRICAL SYMBOLS – PLANS			
CLG.	WALL	FLR.	SYMBOLS DESCRIPTION
			DUPLEX RECEPTACLE
			JUNCTION BOX
			AREA FLOOD LIGHT AND POLE
		+ 18"	INDICATES HEIGHT FROM FINISHED GRADE TO CENTERLINE OF DEVICE
	*		+ 18" U.O.N.
			HANDHOLE, 11"Hx17"Lx18"D, U.O.N.
			FUSIBLE DISCONNECT SWITCH SITE AS NOTED ON PLANS.
			CONTROL STATION, SEE SCHEMATIC DIAGRAM
			FEEDER DESIGNATION SEE SCHEDULE OR ONE LINE DIAGRAM FOR SIZE
			CONDUIT IN SLAB OR UNDER GROUND 3/4"C-2#12 & 1#12 GND. U.O.N.
			CONDUIT EXPOSED 3/4"C-2#12 & 1#12 GND U.O.N.
			QUANTITY #12 WIRE 3/4"C U.O.N. CURVE LINE INDICATES GROUND WIRE
			WIRE SIZE OTHER THAN #12 CURVE LINE INDICATES GROUND WIRE
			GROUNDING CONDUCTOR 30" BELOW GRADE, #4/0 U.O.N.
			EXOTHERMIC WELD CONNECTION
			HOMERUN TO PANEL A, CIRCUIT 1 AND 3
			CONDUIT BENDS TOWARD OBSERVER
			CONDUIT BENDS AWAY FROM OBSERVER
			CONDUIT STUB-OUT AND CAPPED
			FLEXIBLE CONDUIT CONNECTION
			CONDUIT SEAL (HAZARDOUS LOCATION)
			MOTOR CONNECTION
			GROUND ROD, 3/4" x 10'-0" GW NEXT TO SYMBOL INDICATES GROUND ROD WITH GROUND WELL. SEE DETAIL.
			DETAIL CALLOUT- X, DETAIL IDENTIFIER. Y- SHEET WHERE DETAIL IS DRAWN
			JUNCTION BOX OR PULLBOX
	(E)		EXISTING TO REMAIN
	(RS)		EXISTING TO BE REMOVE AND SALVAGED.
	(D)		EXISTING TO BE DEMOLISHED.

POWER WIRE COLOR CODE					
SYSTEM	PHASE A	PHASE B	PHASE C	NEUTRAL	GROUND
208Y/120V	BLACK	RED	BLUE	WHITE	GREEN
480Y/277V	BROWN	ORANGE	YELLOW	GRAY	GREEN
240Y/120V	BLACK	RED	----	WHITE	GREEN
240V	BLACK	RED	BLUE	WHITE	GREEN

ELECTRICAL SYMBOLS – SINGLE LINE DIAGRAM	
	UTILITY METERING
	AMMETER
	VOLTMETER
	VOLTMETER SWITCH
	AMMETER SWITCH
	CURRENT TRANSFORMER, QUANTITY INDICATED
	POWER TRANSFORMER
	CIRCUIT BREAKER, 3 POLE UNLESS NOTED MCP INDICATES MOTOR CIRCUIT PROTECTOR
	MAGNETIC MOTOR STARTER, NEMA SIZE INDICATED FVNR=FULL-VOLTAGE NON-REVERSING 2S, 2W = 2 SPEED, 2 WINDING
	SWITCH
	FUSE
	DISCONNECT SWITCH "F" INDICATES FUSED, SEE PLANS FOR RATING
	MOTOR, 15 HORSEPOWER
	GENERATOR
	SURGE ARRESTER
	LIGHTING ARRESTER
	GROUND
	DELTA CONNECTION
	WYE CONNECTION
	POWER FAILURE RELAY
	GROUND FAULT RELAY
	SPACE HEATER
	FLUORESCENT LIGHT FIXTURE
	VENTILATION FAN
	UTILITY SERVICE
	SOLID STATE STARTER
	VARIABLE FREQUENCY DRIVE

ELECTRICAL SYMBOLS – SCHEMATIC DIAGRAMS		
NORMALLY OPEN	NORMALLY CLOSED	DEVICE
		CONTACT
		PUSH BUTTON SINGLE CIRCUIT MOMENTARY CONTACT
		PUSH BUTTON SINGLE CIRCUIT LOCK-OUT
		LIQUID FLOAT LEVEL SWITCH
		PRESSURE OR VACUUM SWITCH
		FLOW SWITCH
		TEMPERATURE SWITCH
		TIME CONTACT CONTACT ACTION RETARDED ON ENERGIZATION
		TIME CONTACT CONTACT ACTION RETARDED ON DE-ENERGIZATION
		SELECTOR SWITCH (H-O-A)
		MANUAL MOTOR STARTER
		MOTOR OVERLOAD RELAY CONTACT
		MOTOR OVERLOAD HEATER
		PILOT LIGHT R=RED, W=WHITE, G=GREEN, A=AMBER
		PILOT LIGHT-PUSH TO TEST
		RELAY
		TIME DELAY RELAY
		STARTER COIL
		SOLENOID OPERATED VALVE
		MOTOR
		BELL OR BUZZER
		ELAPSED TIME METER
		FUSE
		CONTROL POWER TRANSFORMER
		GROUND
		WIRING IN MOTOR STARTER OR CONTROL PANEL
		FIELD WIRING
		WIRE TERMINAL IN MOTOR STARTER OR CONTROL PANEL
		WIRE TERMINAL IN PLC
		PHASE/POWER FAILURE RELAY
		SPACE HEATER
		RESISTOR
		CIRCUIT BREAKER

- GENERAL NOTES:**
- INSTALLATION SHALL MEET ALL REQUIREMENTS OF THE LATEST EDITION OF THE NATIONAL ELECTRICAL CODE (NEC) AND ALL LOCAL CODES HAVING JURISDICTION.
 - AN EQUIPMENT GROUNDING CONDUCTOR SIZED PER THE NEC SHALL BE PULLED IN ALL ELECTRICAL CONDUITS (POWER AND CONTROL) WHETHER OR NOT SHOWN ON THE PLANS.
 - ALL EQUIPMENT SHALL BE NEW, UNUSED, AND U.L. LISTED (WHERE A U.L. LISTING IS AVAILABLE FOR THAT CLASS OF EQUIPMENT).
 - ALL EQUIPMENT FURNISHED AND INSTALLED BY THE CONTRACTOR SHALL BE GUARANTEED AGAINST DEFECTS IN MATERIALS AND WORKMANSHIP FOR A PERIOD OF ONE YEAR FROM THE DATE OF ACCEPTANCE.
 - THE DRAWINGS ARE NOT INTENDED TO SHOW THE EXACT LOCATION OF CONDUIT RUNS AND STUB-UPS. THESE ARE TO BE COORDINATED WITH OTHER TRADES TO AVOID CONFLICTS AND MAINTAIN REQUIRED CLEARANCES. THE CONTRACTOR SHALL COORDINATE CONDUIT STUB-UP LOCATIONS BASED UPON APPROVED EQUIPMENT SHOP DRAWINGS, UNLESS SHOWN OTHERWISE.
 - ALL LIGHTING & RECEPTACLE HOMERUNS SHALL BE 3/4" CONDUIT CONTAINING (AS A MINIMUM) 2#12 AND 1 #12 GND.
 - DETAILS APPLY TO ALL WORK, EVEN IF DETAIL CALLOUT IS NOT SPECIFICALLY CALLED OUT ON DRAWINGS.

REV	DATE	BY	DESCRIPTION

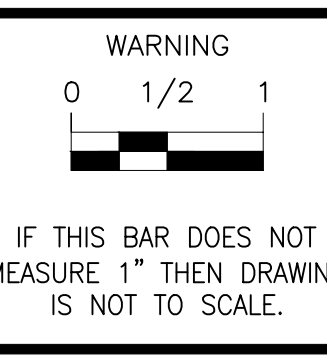

DESIGNED	JCC
DRAWN	KSC
CHECKED	DSW
SCALE	

PREPARED BY:

JOHN C. CALTON
REE No.: 14099

DATE

805 AEROVISTA PLACE, SUITE 201
PHONE: (805) 457-8833

SAN LUIS OBISPO, CA 93401
FAX: (805) 888-2764

HERITAGE RANCH COMMUNITY SERVICES DISTRICT
4870 HERITAGE ROAD
PASO ROBLES, CA 93446

APPROVED: _____
DATE _____

WATER RESOURCE RECOVERY FACILITY UPGRADE
ELECTRICAL

ELECTRICAL NOTES, SYMBOLS, AND ABBREVIATIONS

DRAWING

00-E001

SHEET X OF XX
PROJECT # _____

DRAFT - NOT FOR CONSTRUCTION

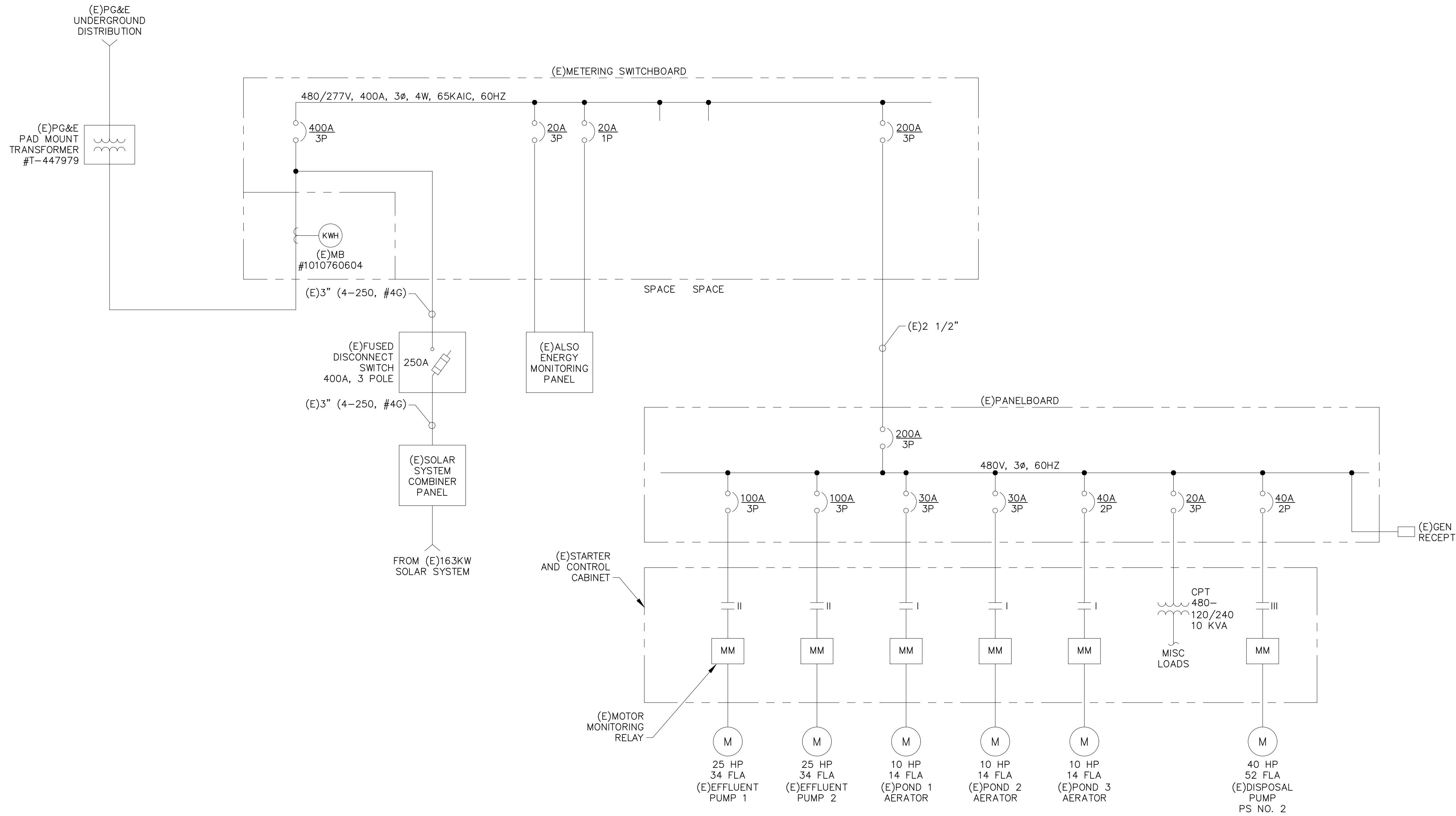

LOAD CALCULATIONS AT 480 VAC, 3 PHASE	
LOAD DESCRIPTION	AMPS
EFFLUENT PUMP 1 (25 HP)	34
EFFLUENT PUMP 2 (25 HP)	34
POND 1 AERATOR (10 HP)	14
POND 2 AERATOR (10 HP)	14
POND 3 AERATOR (10 HP)	14
CONTROL POWER TRANSFORMER (10 KVA)	20
DISPOSAL PUMP (40 HP)	52
SUBTOTAL:	182
25% CONTINUOUS LOAD:	46
TOTAL AMPS:	228

EXISTING SINGLE LINE DIAGRAM

DRAFT - NOT FOR CONSTRUCTION

WARNING IF THIS BAR DOES NOT MEASURE 1" THEN DRAWING IS NOT TO SCALE.	DESIGNED: JCC DRAWN: KSC CHECKED: DSW SCALE:	PREPARED BY: JOHN C. CALTON REE No.: 14099	 HERITAGE RANCH COMMUNITY SERVICES DISTRICT 4870 HERITAGE ROAD PASO ROBLES, CA 93446 805 AEROVISTA PLACE, SUITE 201 PHONE: (805) 457-8833 SAN LUIS OBISPO, CA 93401 FAX: (805) 888-2764	APPROVED: _____ _____ POSITION _____ DATE _____	WATER RESOURCE RECOVERY FACILITY UPGRADE ELECTRICAL EXISTING SINGLE LINE DIAGRAM	DRAWING 00-E601 SHEET X OF XX PROJECT # _____
	REV DATE BY DESCRIPTION					

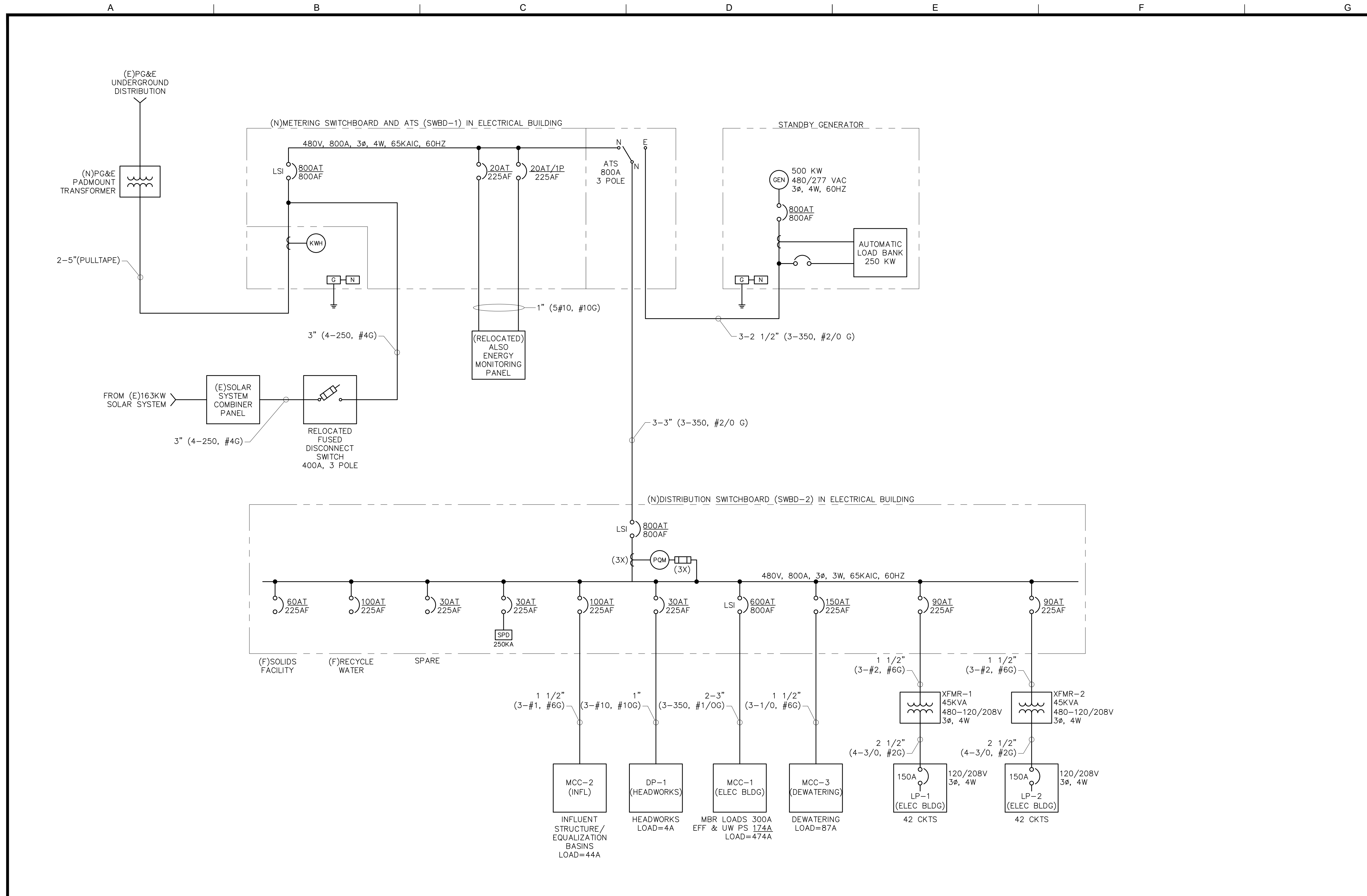

PROPOSED SINGLE LINE DIAGRAM

LOAD CALCULATIONS AT 480 VAC		
DESCRIPTION	CONNECTED AMPS	DUTY AMPS
INFLUENT STRUCTURE/ EQUALIZATION PUMPS		
EQUALIZATION BASIN PUMP 1 (7.5 HP)	11	11
EQUALIZATION BASIN PUMP 2 (7.5 HP)	11	(NOTE 1)
EQUALIZATION BASIN AERATOR 1 (7.5 HP)	11	11
EQUALIZATION BASIN AERATOR 2 (7.5 HP)	11	(NOTE 1)
SUBTOTALS	44	22
HEADWORKS		
COARSE SCREEN 1 (2 HP)	3.4	3.4
SUBTOTALS	3.4	3.4
PACKAGED MBR FACILITY		
FINE SCREEN GRIT REMOVAL (3 HP)	4.8	4.8
AIR DRYER (1 HP)	1.8	1.8
BLOWER 1 - BIOLOGICAL REACTOR (20 HP)	27	27
BLOWER 2 - BIOLOGICAL REACTOR (20 HP)	27	27
BLOWER 3 - BIOLOGICAL REACTOR (20 HP)	27	(NOTE 1)
BLOWER 1 - MEMBRANE (15 HP)	21	21
BLOWER 2 - MEMBRANE (15 HP)	21	21
BLOWER 3 - MEMBRANE (15 HP)	21	(NOTE 1)
AIR COMPRESSOR (7.5 HP)	11	11
ANOXIC TANK MIXER 1 (5 HP)	7.6	7.6
ANOXIC TANK MIXER 2 (5 HP)	7.6	7.6
DEOXYGENATION TANK MIXER 1 (3 HP)	4.8	4.8
DEOXYGENATION TANK MIXER 2 (3 HP)	4.8	4.8
WAS PUMP 1 (3 HP)	4.8	4.8
WAS PUMP 2 (3 HP)	4.8	(NOTE 1)
RAS PUMP 1 (7.5 HP)	11	11
RAS PUMP 2 (7.5 HP)	11	11
RAS PUMP 3 (7.5 HP)	11	(NOTE 1)
IMLR FLOW PUMP 1 (3 HP)	4.8	4.8
IMLR FLOW PUMP 2 (3 HP)	4.8	4.8
PERMEATE PUMP 1 (10 HP)	14	14
PERMEATE PUMP 2 (10 HP)	14	14
PERMEATE PUMP 3 (10 HP)	14	(NOTE 1)
WATER HEATER (12 KW)	19	(NOTE 1)
SUBTOTALS	299.6	202.8
CHEMICAL FACILITY		
HYPO DOSING PUMP 1 (0.25 HP)	0.5	0.5
HYPO DOSING PUMP 2 (0.25 HP)	0.5	(NOTE 1)
CAUSTIC DOSING PUMP 1 (0.25 HP)	0.5	0.5
CAUSTIC DOSING PUMP 2 (0.25 HP)	0.5	(NOTE 1)
ACID DOSING PUMP 1 (0.25 HP)	0.5	0.5
ACID DOSING PUMP 2 (0.25 HP)	0.5	(NOTE 1)
CARBON DOSING PUMP 1 (0.25 HP)	0.5	0.5
CARBON DOSING PUMP 2 (0.25 HP)	0.5	(NOTE 1)
WATER HEATER (40 KW)	60	(NOTE 1)
SUBTOTALS	64.0	2.0
DEWATERING FACILITY		
SLUDGE FEED PUMP 1 (3 HP)	4.8	4.8
SLUDGE FEED PUMP 2 (3 HP)	4.8	(NOTE 1)
DEWATERING UNIT (3 HP)	4.8	4.8
FLOC TANK MIXER (1 HP)	1.8	1.8
SLUDGE CONVEYOR (3 HP)	4.8	4.8
SPEED REDUCER (2 HP)	3	3.4
POLYELECTROLYTE PREP UNIT (1 HP)	1.8	1.8
POLYELECTROLYTE DOSING PUMP 1 (5 HP)	7.6	7.6
POLYELECTROLYTE DOSING PUMP 2 (5 HP)	7.6	(NOTE 1)
SOLIDS STORAGE TANK BLOWER 1 (5 HP)	7.6	7.6
SOLIDS STORAGE TANK BLOWER 2 (5 HP)	7.6	(NOTE 1)
ODOR CONTROL (7.5 HP)	11	11
WATER HEATER (12 KW)	19	(NOTE 1)
SUBTOTALS	86.6	47.6
EFFLUENT AND UW PUMP STATION		
EFFLUENT PUMP 1 (30 HP)	40	40
EFFLUENT PUMP 2 (30 HP)	40	40
EFFLUENT PUMP 3 (30 HP)	40	(NOTE 1)
UTILITY WATER BOOSTER PUMP 1 (20 HP)	27	27
UTILITY WATER BOOSTER PUMP 2 (20 HP)	27	(NOTE 1)
SUBTOTALS	174.0	107.0
MISC. ELECTRICAL LOADS		
120/208V TRANSFORMER 1 (45 KVA)	54	32.4
120/208V TRANSFORMER 2 (45 KVA)	54	32.4
OPERATIONS BUILDING	25	15
FUTURE LOADS (SOLIDS FACILITY)	100	80
SUBTOTALS	233.0	159.8
FUTURE SOLIDS HANDLING		
DIGESTION (20 HP)	27	27
THICKENING (10 HP)	14	14
SUBTOTALS	41.0	41.0
FUTURE RECYCLE WATER PUMPS		
RECYCLED WATER PUMP 1 (20 HP)	27	27
RECYCLED WATER PUMP 2 (20 HP)	27	27
SUBTOTALS	54.0	54.0
GRAND SUBTOTALS	1000	640
25% DUTY (CONTINUOUS) LOAD:	160	
TOTAL LOAD:	800	

NOTES:
1. DUTY LOAD, NOT PART OF CONTINUOUS LOAD CALCULATIONS.

DRAFT - NOT FOR CONSTRUCTION

REV	DATE	BY	DESCRIPTION

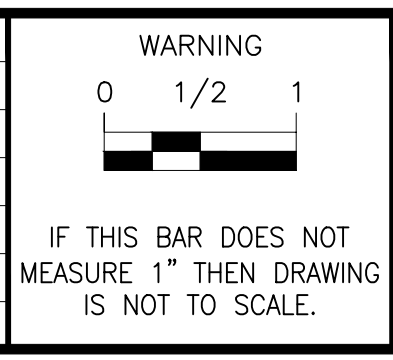

DESIGNED: JCC
DRAWN: KSC
CHECKED: DSW
SCALE: _____

PREPARED BY:
JOHN C. CALTON
REE No.: 14099
DATE: _____

605 AEROVISTA PLACE, SUITE 201
PHONE: (805) 457-8833
SAN LUIS OBISPO, CA 93401
FAX: (805) 888-2764

HERITAGE RANCH COMMUNITY SERVICES DISTRICT
4870 HERITAGE ROAD
PASO ROBLES, CA 93446
APPROVED: _____
POSITION: _____ DATE: _____

WATER RESOURCE RECOVERY FACILITY UPGRADE
ELECTRICAL
PROPOSED SINGLE LINE DIAGRAM

DRAWING
00-E602
SHEET X OF XX
PROJECT # _____

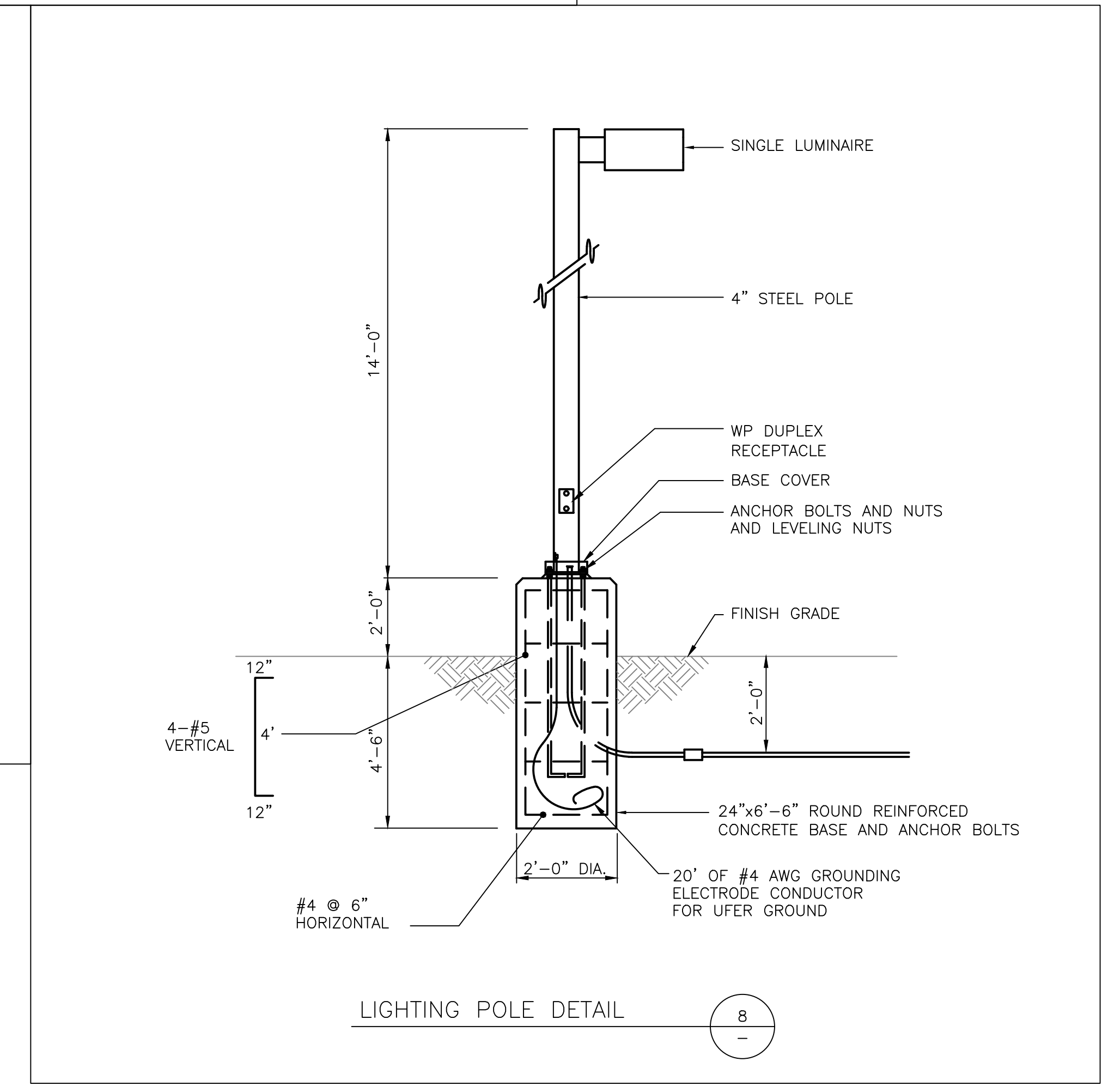
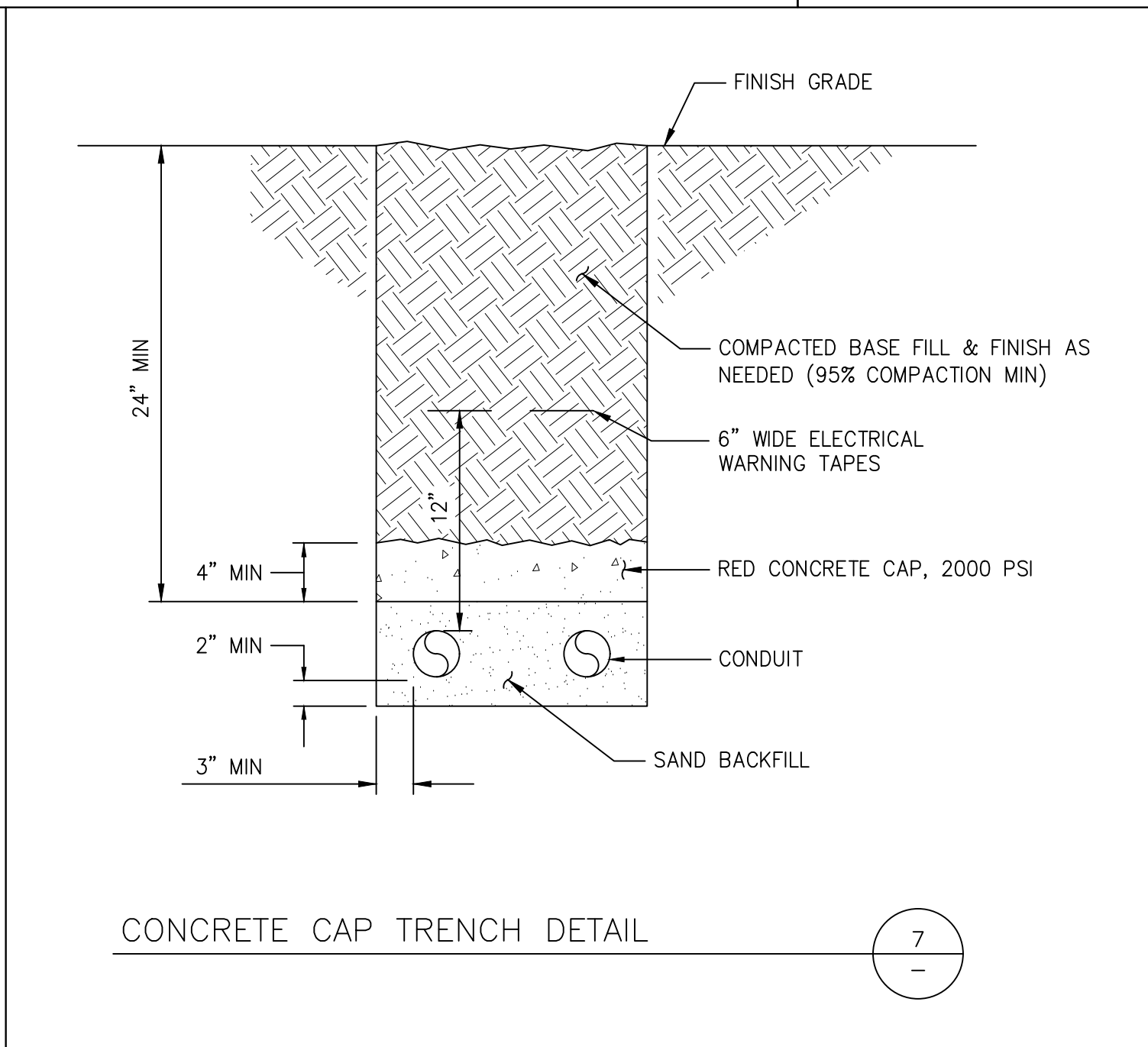
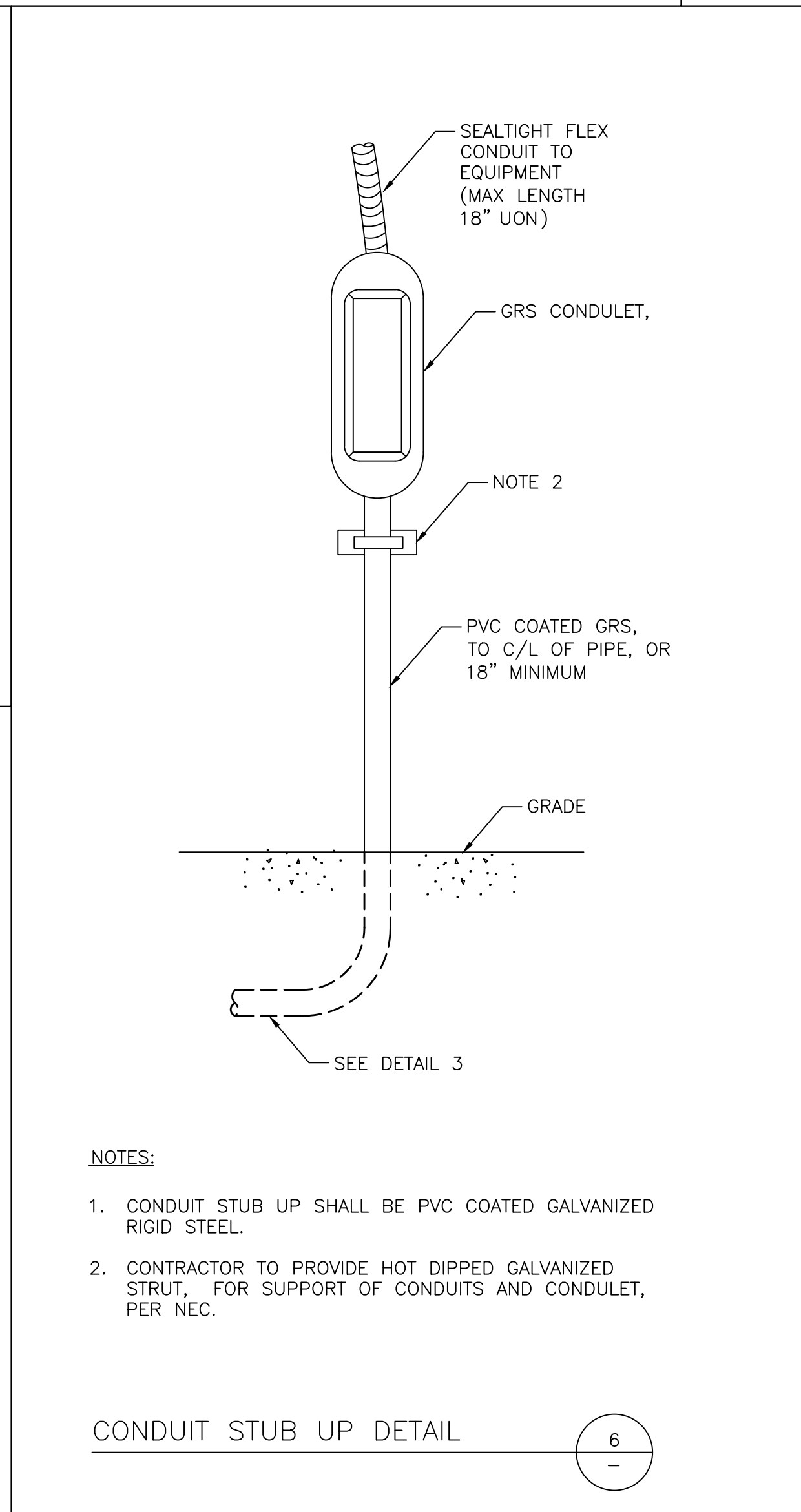
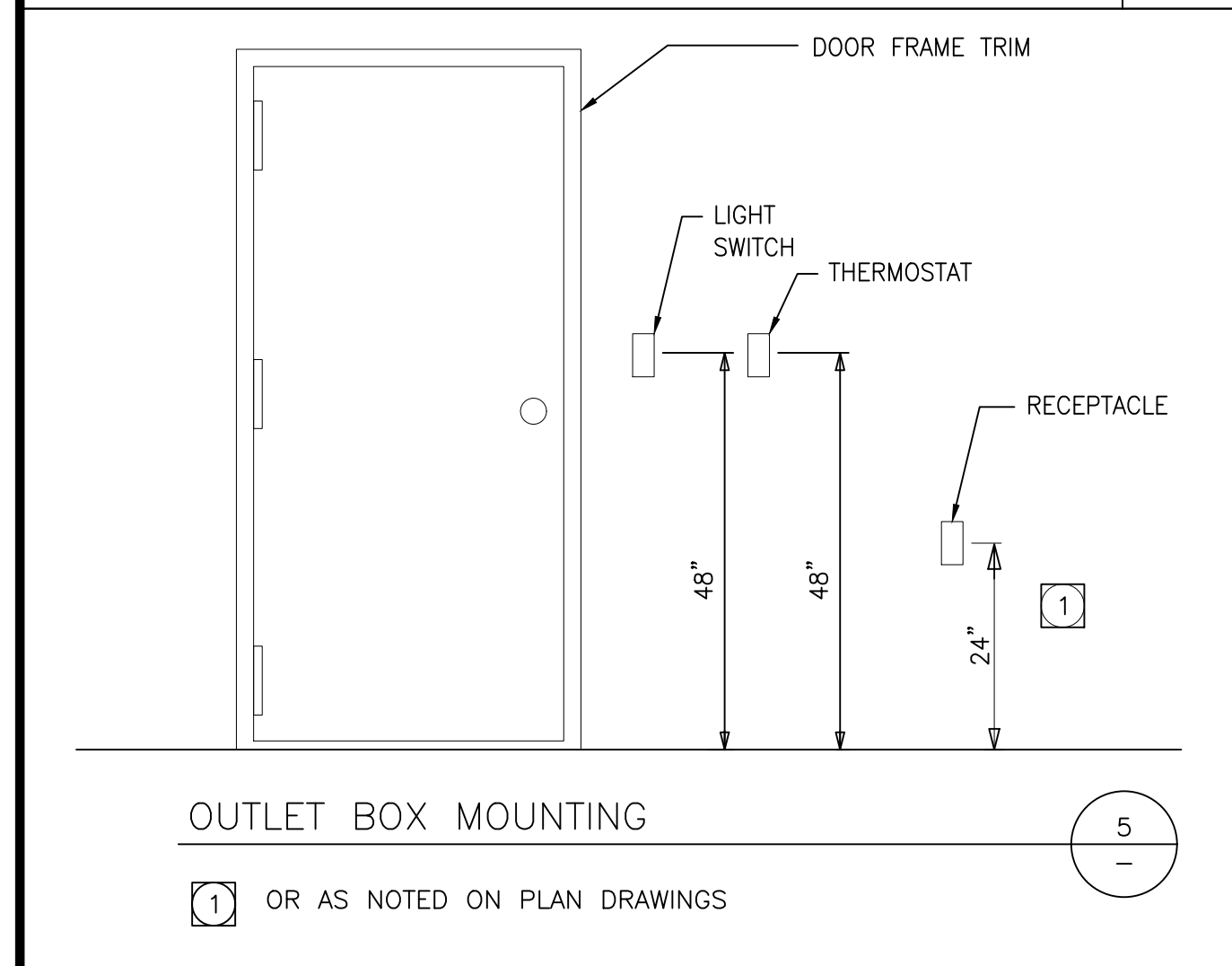
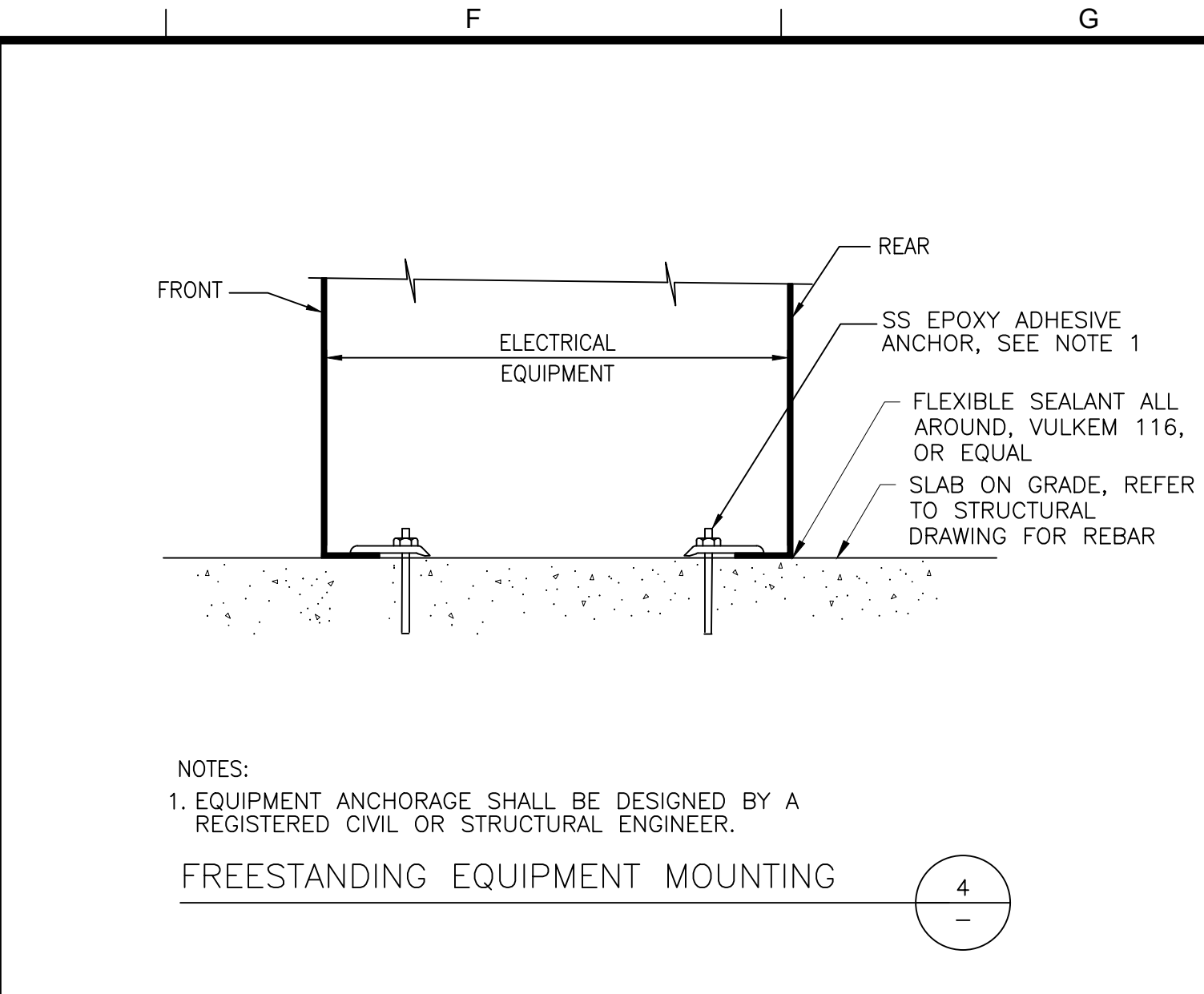
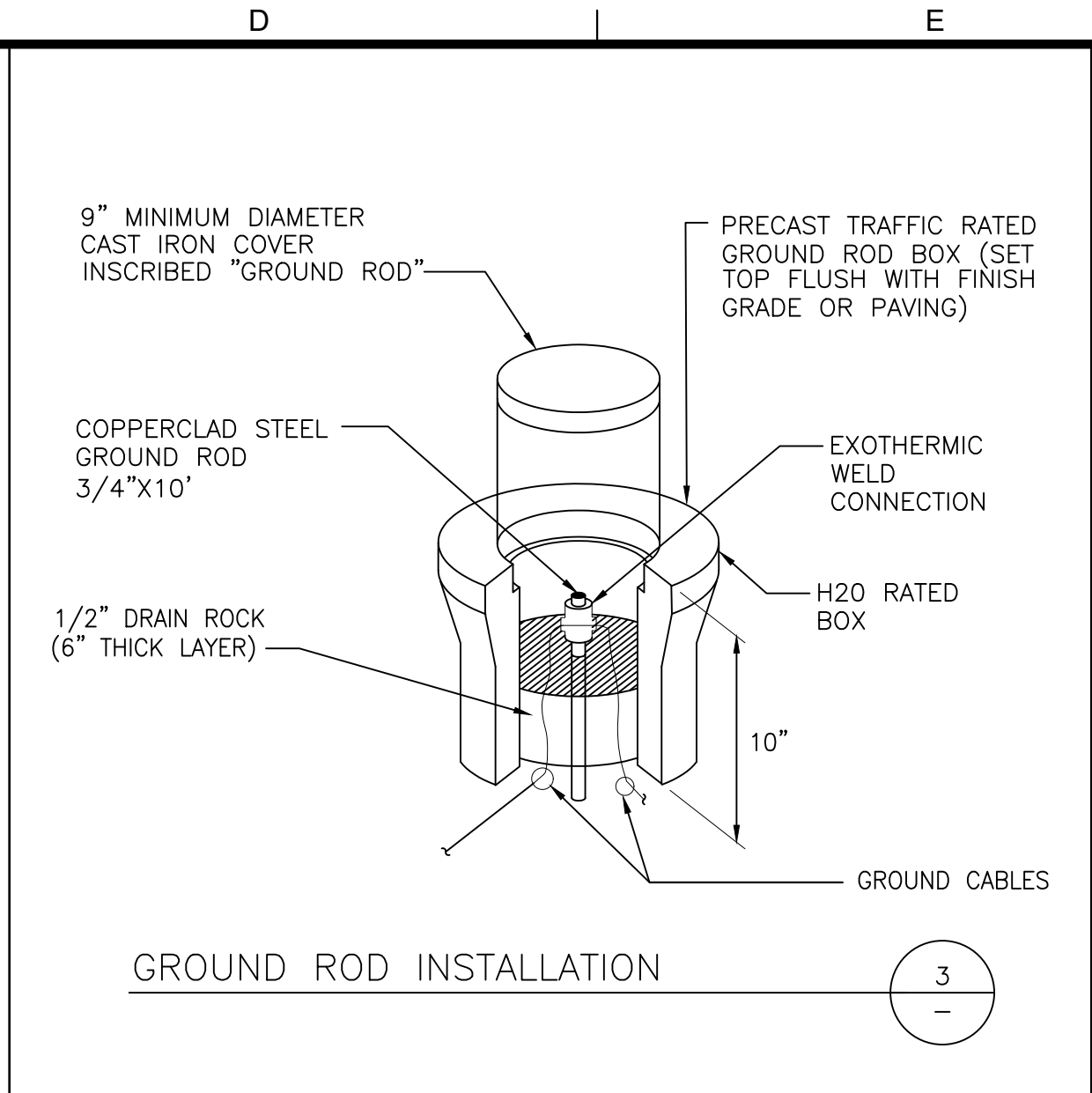
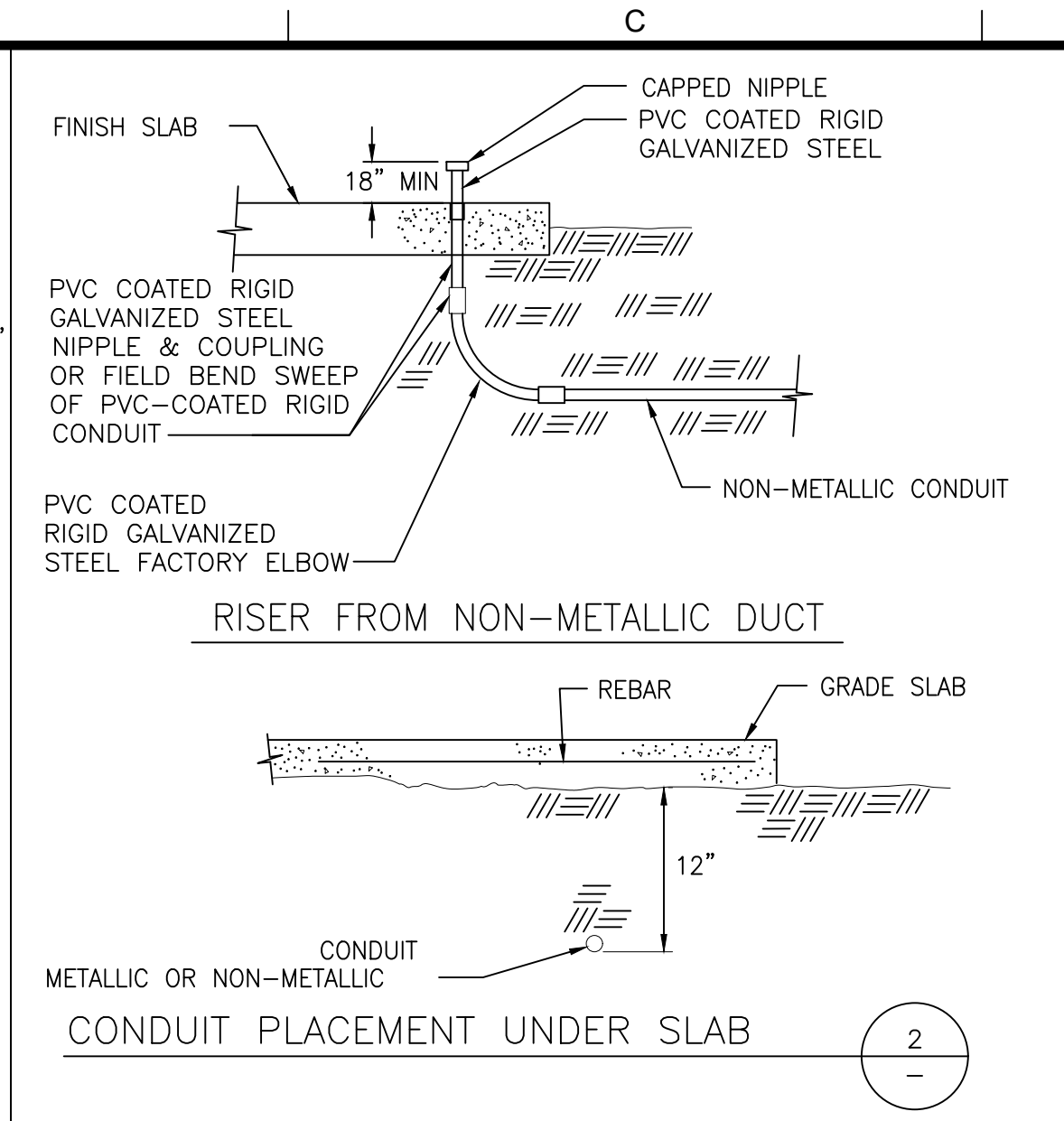
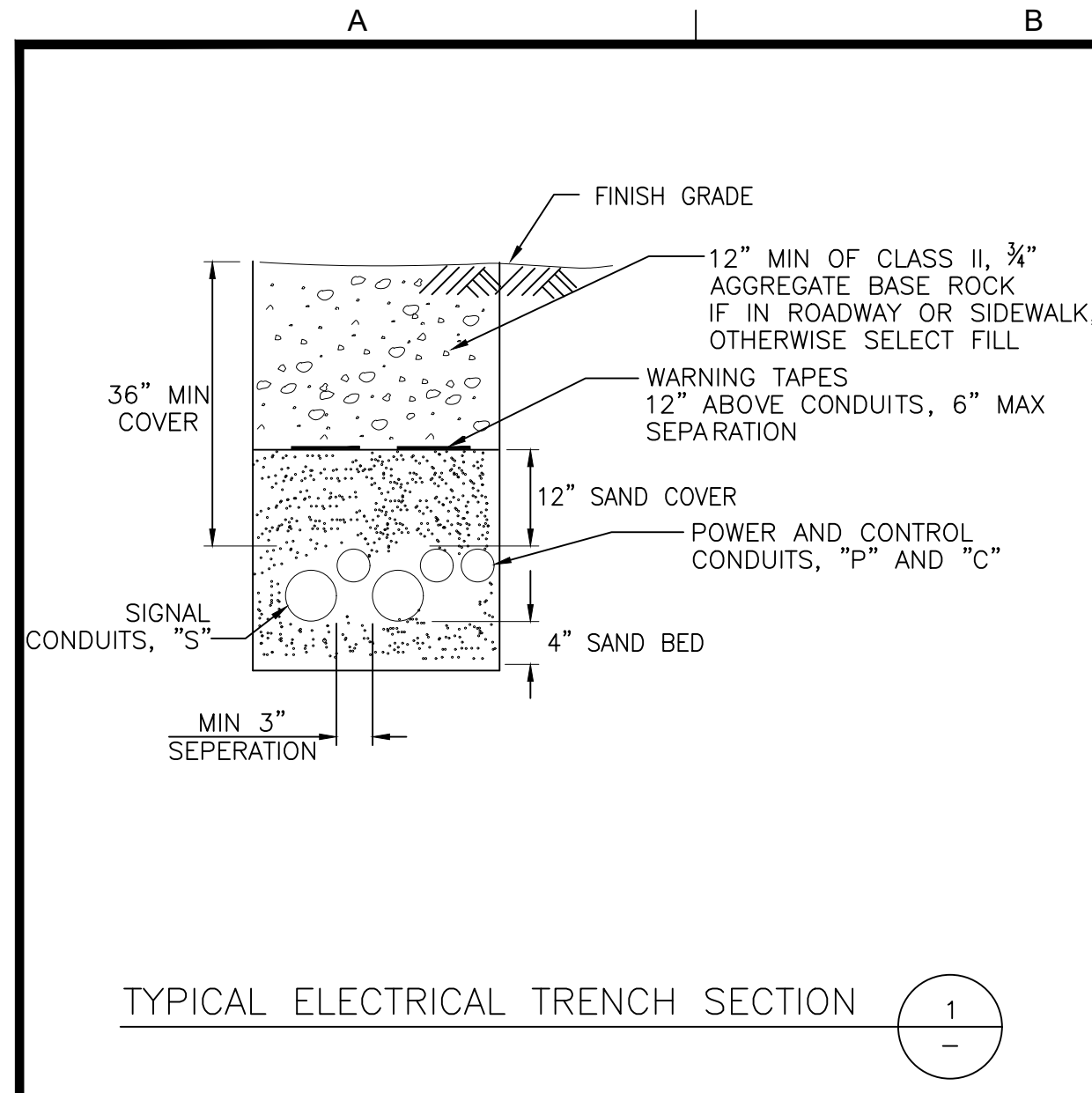

DRAFT - NOT FOR CONSTRUCTION

REV	DATE	BY	DESCRIPTION

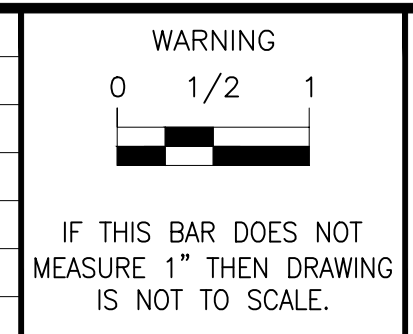

DESIGNED JCC
DRAWN KSC
CHECKED DSW
SCALE

PREPARED BY:
JOHN C. CALTON
REE No.: 14099

DATE

WSC

805 AEROVISTA PLACE, SUITE 201
PHONE: (805) 457-8833

SAN LUIS OBISPO, CA 93401
FAX: (805) 888-2764

HERITAGE RANCH COMMUNITY SERVICES DISTRICT
4870 HERITAGE ROAD
PASO ROBLES, CA 93446

APPROVED: _____ POSITION _____ DATE _____

WATER RESOURCE RECOVERY FACILITY UPGRADE
ELECTRICAL

ELECTRICAL DETAILS 1

DRAWING
00-E701
SHEET X OF XX
PROJECT #

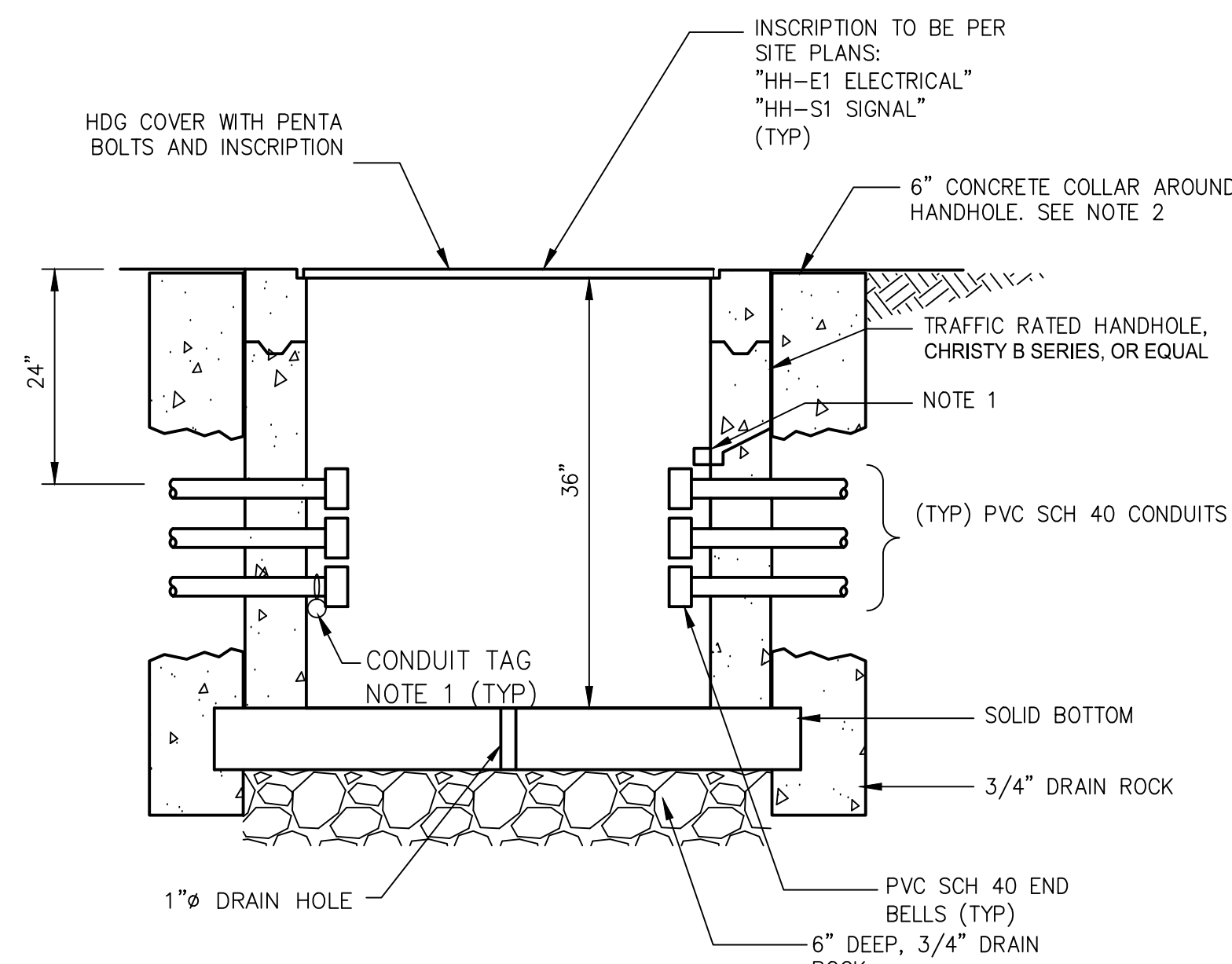

- NOTES:
1. PROVIDE AND INSTALL PHENOLIC TAG, INSCRIBED WITH CONDUIT NUMBER, ON EACH CONDUIT.
 2. INSTALL TRAFFIC RATED HANDHOLE WITH 6" CONCRETE COLLAR. REFER TO CHRISTY CONCRETE TRAFFIC RATED INSTALLATION GUIDE.
 3. LOOP CABLES WITHIN HANDHOLE. TIE WRAP EACH CIRCUIT.
 4. DUCT SEAL CONDUITS.

PRE-CAST HANDHOLE DETAIL 11

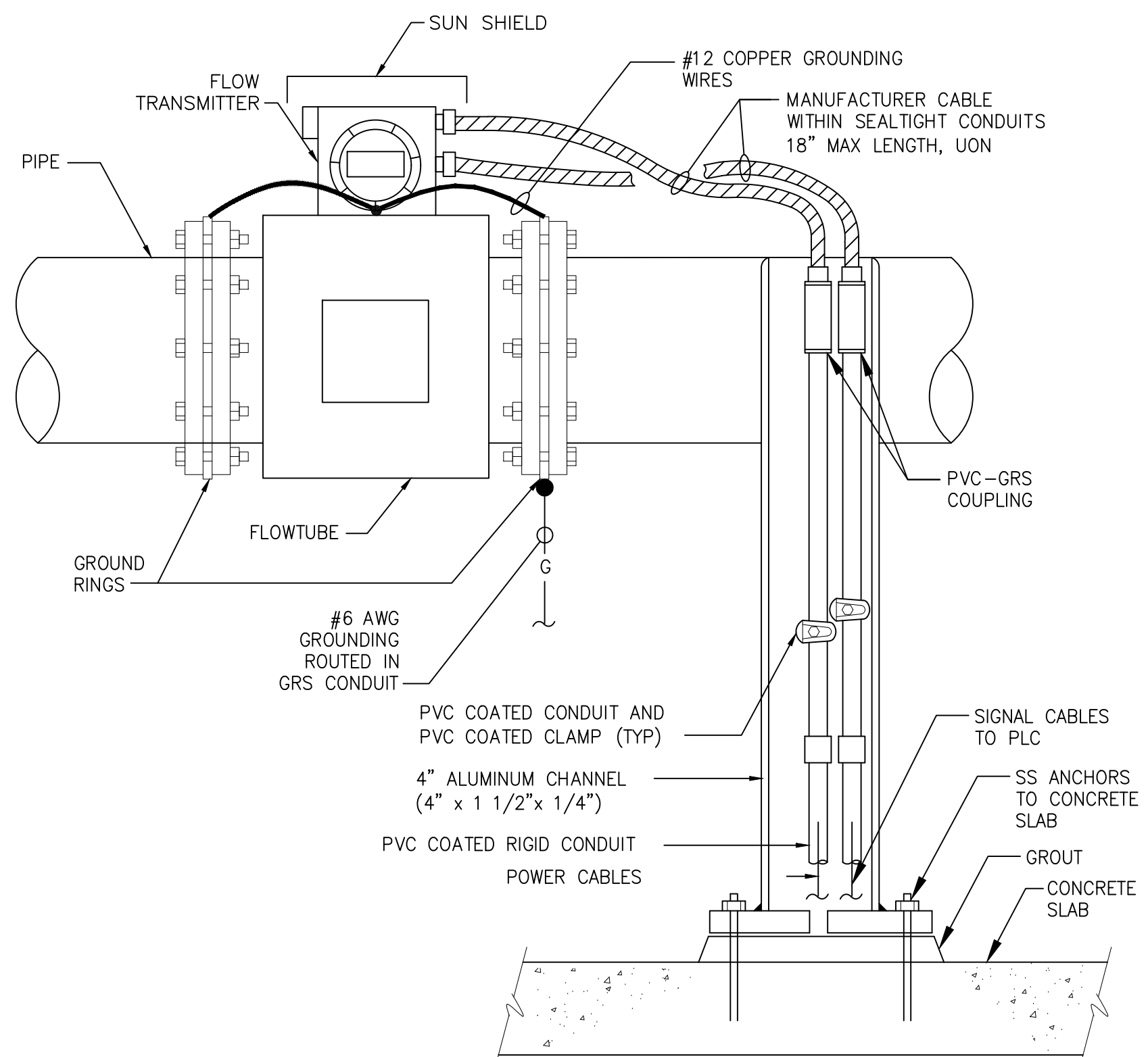

FLOWMETER WIRING DETAIL 12

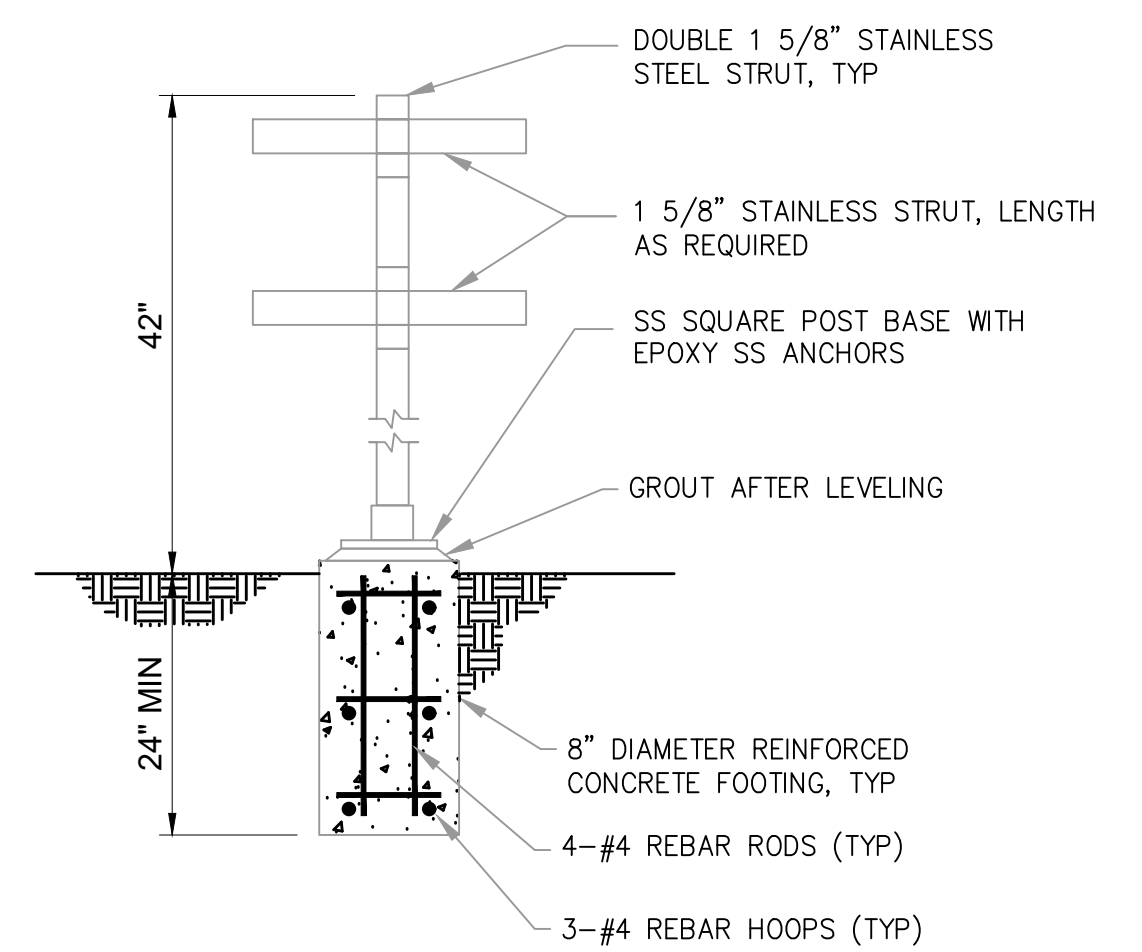

- NOTES:
1. ALL STRUT AND HARDWARE SHALL BE TYPE 316 STAINLESS STEEL.

SINGLE STANCHION DETAIL 13

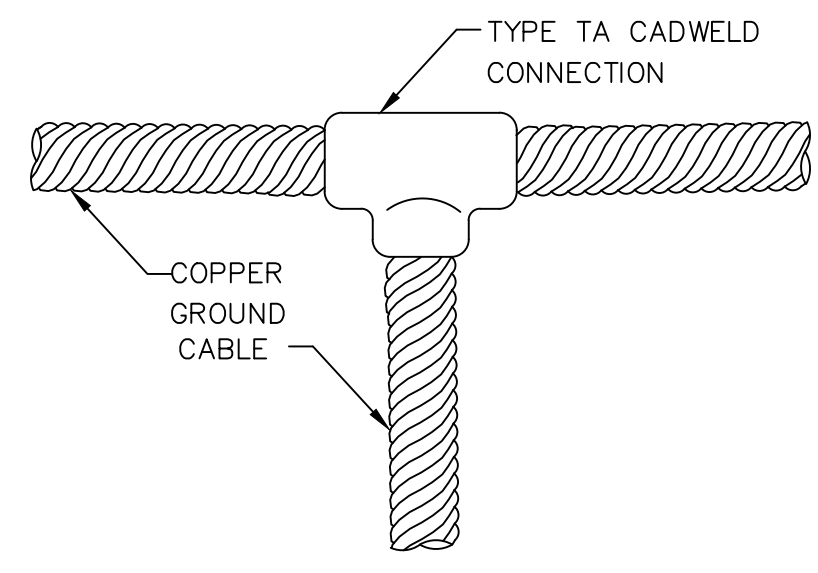

BURIED GROUND CABLE CONNECTION 14

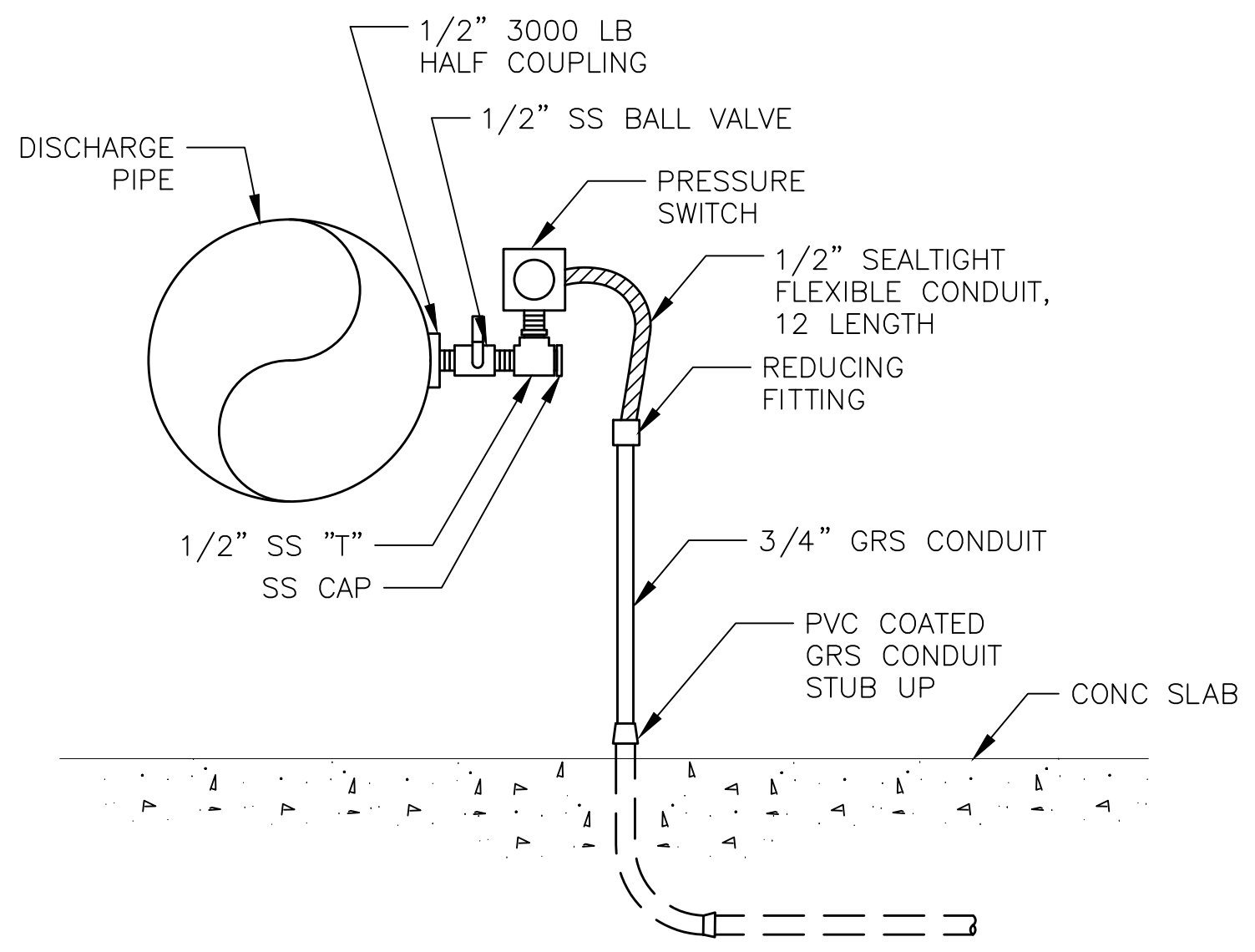

PUMP DISCHARGE PRESSURE SWITCH 15

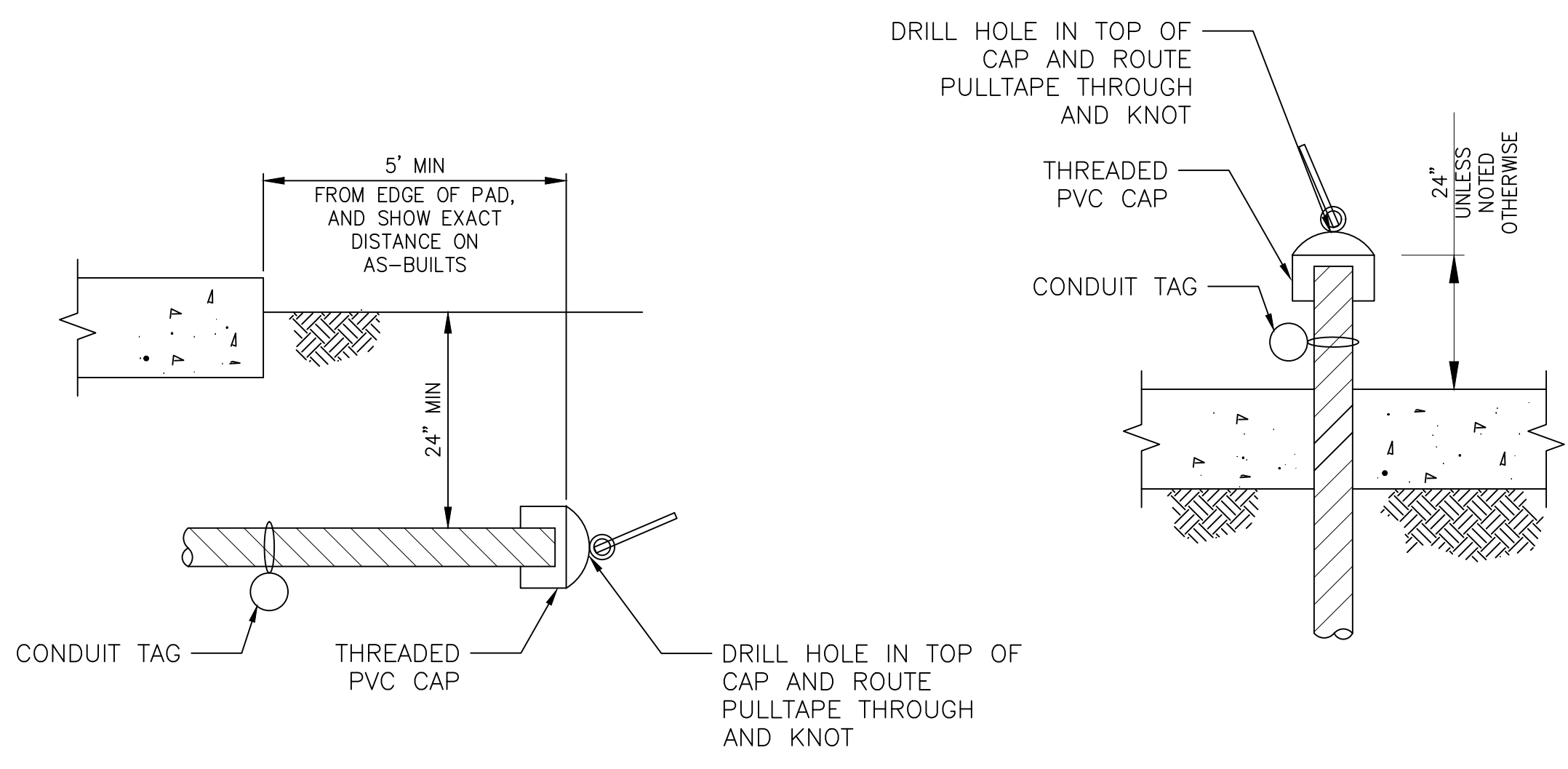

SPARE CONDUIT DETAIL 16

DRAFT - NOT FOR CONSTRUCTION

REV	DATE	BY	DESCRIPTION

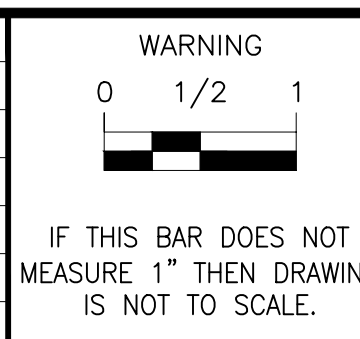

DESIGNED JCC
DRAWN KSC
CHECKED DSW
SCALE

PREPARED BY:
JOHN C. CALTON
REE No.: 14099

DATE

HERITAGE RANCH COMMUNITY SERVICES DISTRICT
4870 HERITAGE ROAD
PASO ROBLES, CA 93446

APPROVED: _____ POSITION _____ DATE _____

805 AEROVISTA PLACE, SUITE 201 SAN LUIS OBISPO, CA 93401
PHONE: (805) 457-8833 FAX: (805) 888-2764

HERITAGE RANCH COMMUNITY SERVICES DISTRICT
4870 HERITAGE ROAD
PASO ROBLES, CA 93446

APPROVED: _____ POSITION _____ DATE _____

WATER RESOURCE RECOVERY FACILITY UPGRADE
ELECTRICAL

ELECTRICAL DETAILS 2

DRAWING
00-E702
SHEET X OF XX
PROJECT #

INSTRUMENTATION IDENTIFICATION

EXAMPLE SYMBOLS

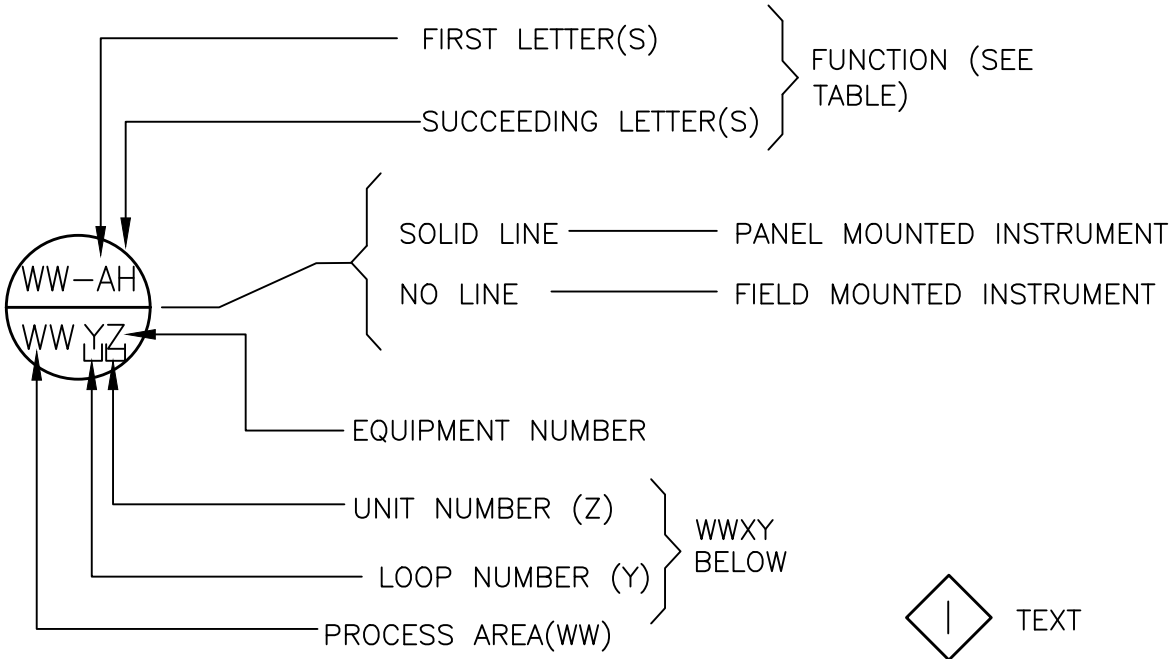

INSTRUMENT



PLC (PROGRAMMABLE LOGIC CONTROLLER)

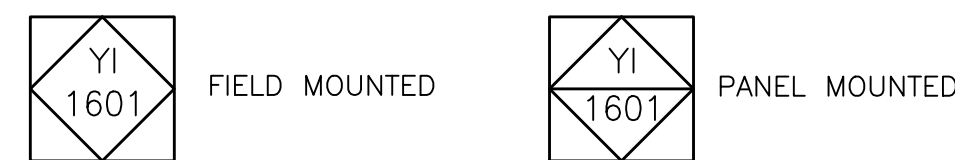

HMI (HUMAN-MACHINE INTERFACE)



INSTRUMENT SOCIETY OF AMERICA TABLE

LETTER	FIRST LETTER (S)		SUCCEEDING LETTERS		
	PROCESS OR INITIATING VARIABLE	MODIFIER	READOUT OR PASSIVE FUNCTION	OUTPUT FUNCTION	MODIFIER
A	ANALYSIS (+)		ALARM		
B	BURNER FLAME		USERS CHOICE (+)	USERS CHOICE (+)	USERS CHOICE (+)
C	CONDUCTIVITY			CONTROL	
D	DENSITY (S.G)	DIFFERENTIAL			
E	VOLTAGE		PRIMARY ELEMENT		
F	FLOW RATE	RATIO			
G	GAUGE		GLASS	GATE	
H	HAND (MANUAL)				
I	CURRENT		INDICATE		
J	POWER	SCAN			
K	TIME OR SCHEDULE			CONTROL STATION	
L	LEVEL		LIGHT (PILOT)		LOW
M	MOTION				MIDDLE
N	USERS CHOICE (+)		USERS CHOICE (+)	USERS CHOICE (+)	USERS CHOICE (+)
O	USERS CHOICE (+)		ORIFICE		
P	PRESSURE (OR VACUUM)		POINT (TEST CONNECTION)		
Q	QUANTITY OR EVENT	INTEGRATE	INTEGRATE		
R			RECORD OR POINT		
S	SPEED OR FREQUENCY	SAFETY		SWITCH	
T	TEMPERATURE			TRANSMIT	
U	MULTIVARIABLE (+)		MULTIFUNCTION	MULTIFUNCTION (+)	MULTIFUNCTION (+)
V	VISCOSITY			VALVE OR DAMPER	
W	WEIGHT OR FORCE		WELL		
X	UNCLASSIFIED (+)		UNCLASSIFIED (+)	UNCLASSIFIED (+)	UNCLASSIFIED (+)
Y	EVENT		RELAY OR COMPUTE (+)		
Z	POSITION		DRIVE, ACTUATE OR UNCLASSIFIED FINAL CONTROL ELEMENT		

(+) WHEN USED, EXPLANATION IS SHOWN ADJACENT TO INSTRUMENT SYMBOL. SEE ABBREVIATIONS.

VALVE SYMBOLS

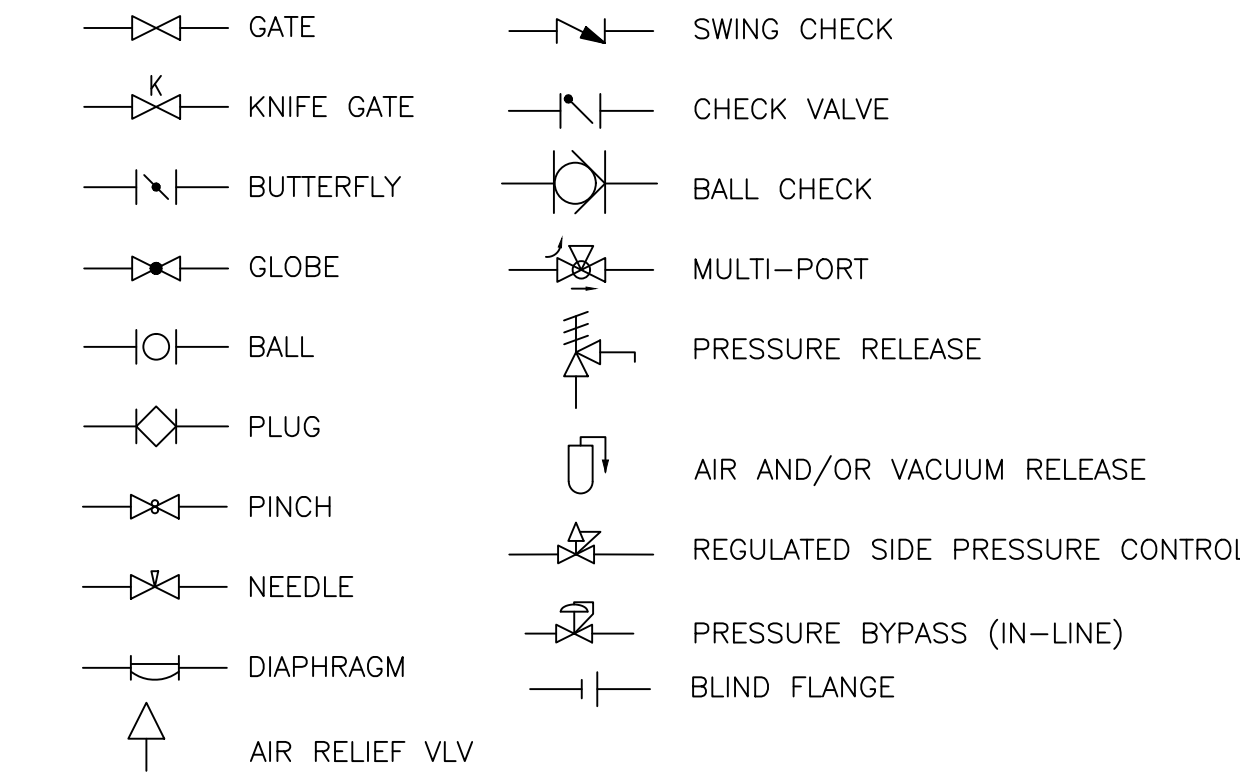

ACTUATOR SYMBOLS

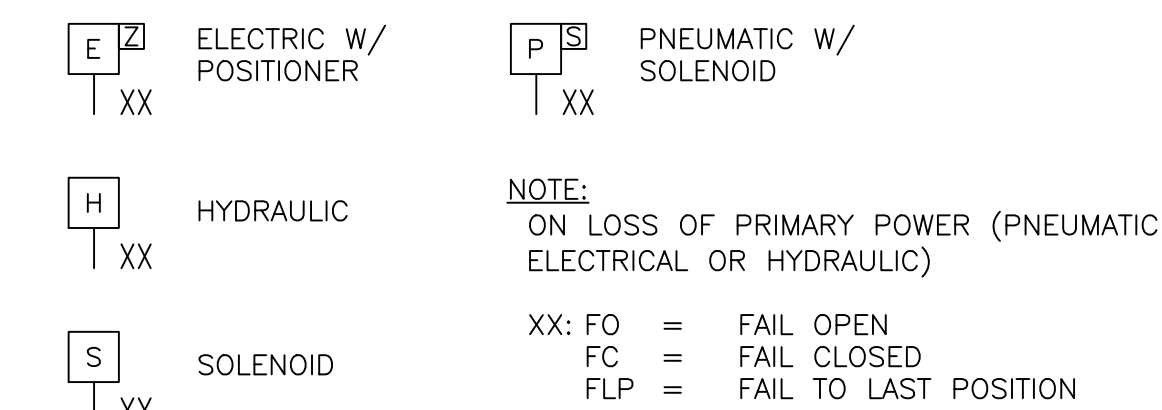

GATE SYMBOLS

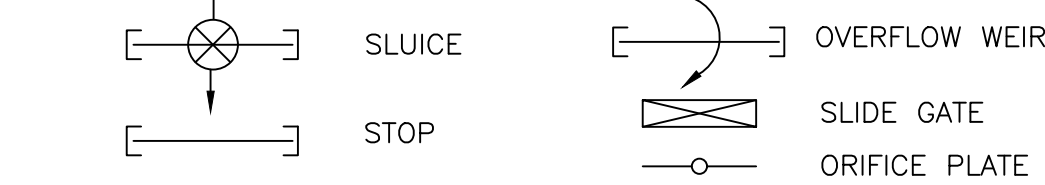

PRIMARY ELEMENT SYMBOLS

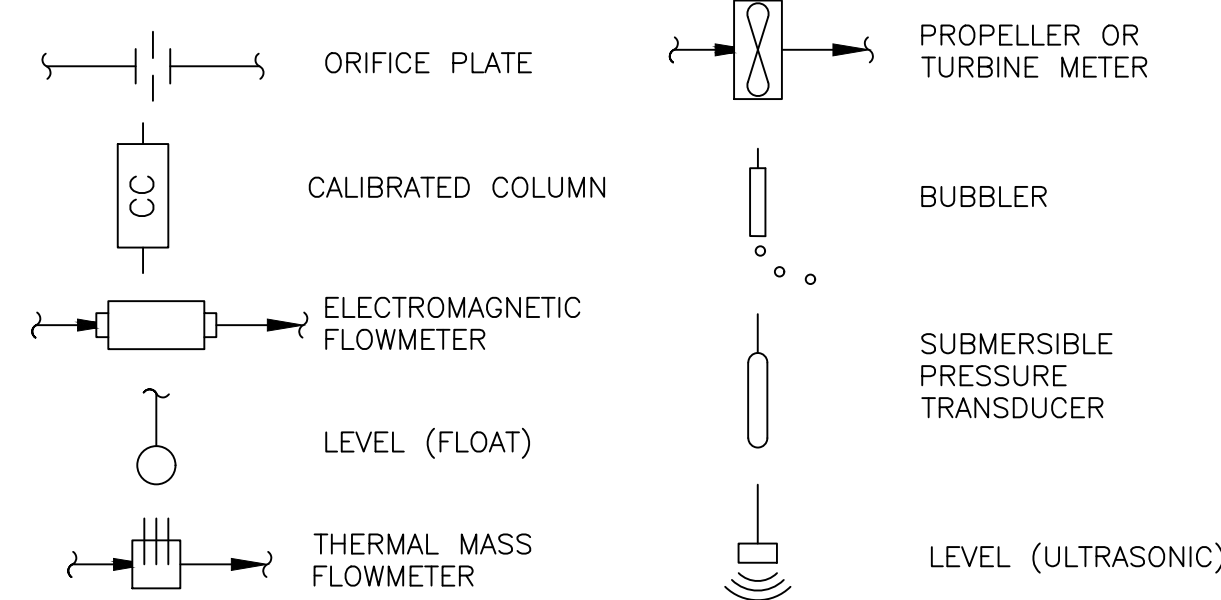

EQUIPMENT SYMBOLS

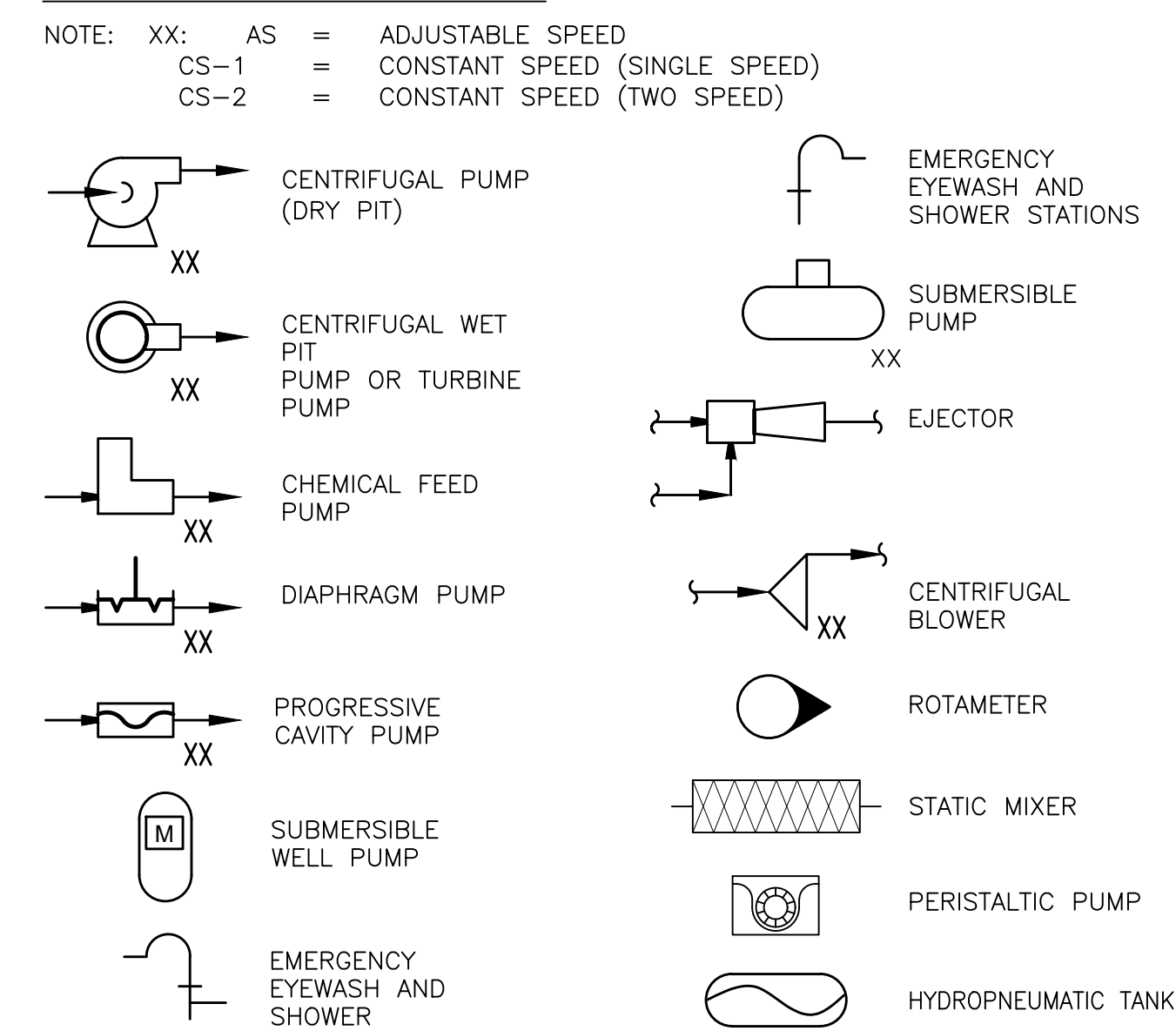

MISCELLANEOUS SYMBOLS

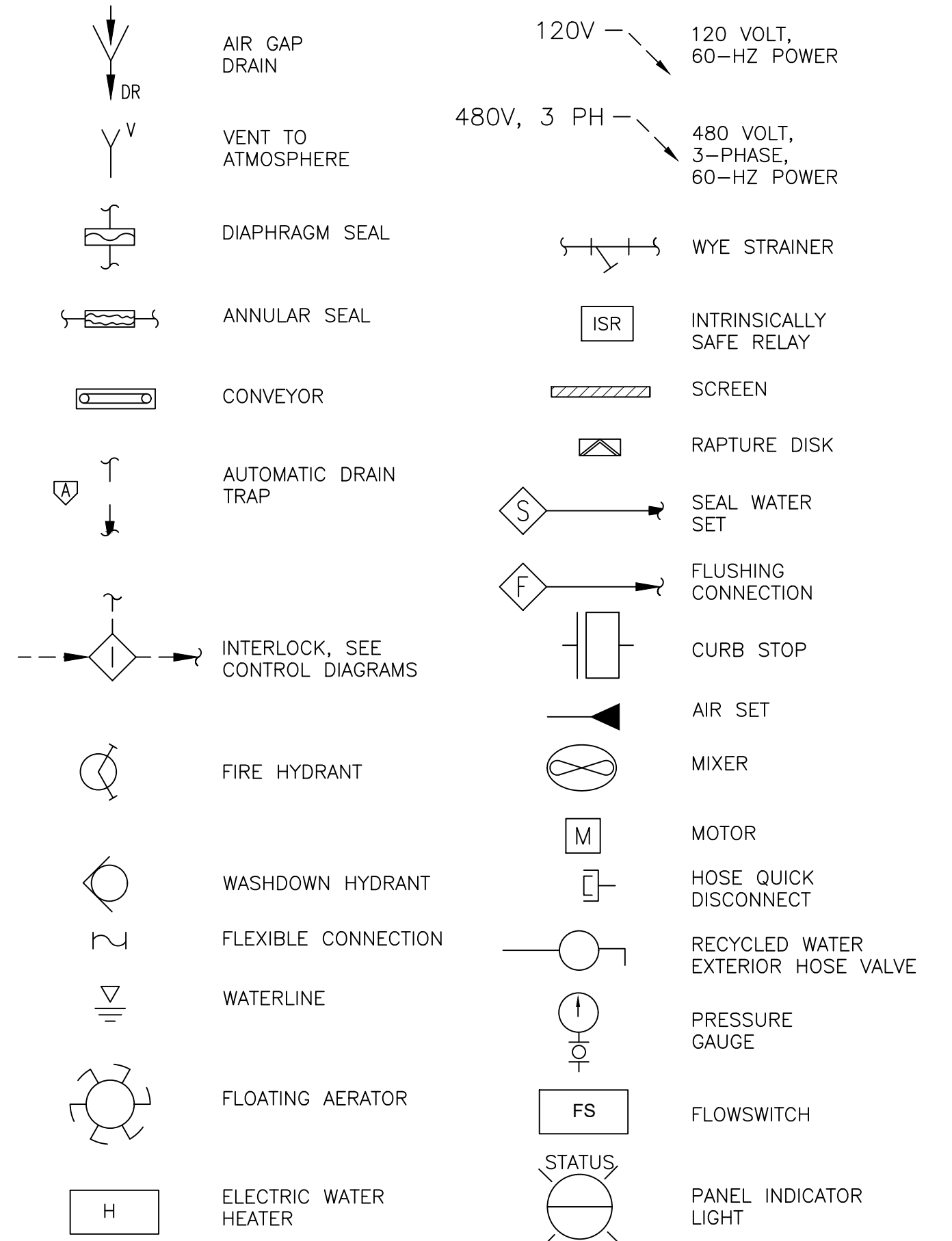

ABBREVIATIONS

ACK	ACKNOWLEDGE
AFD	ADJUSTABLE FREQUENCY DRIVE
AHU	AIR HANDLING UNIT
CS	CONSTANT SPEED
DC	DIRECT CURRENT
EF	EXHAUST FAN
HMI	HUMAN-MACHINE INTERFACE
HOA	HAND-OFF-AUTO
HVAC	HEATING, VENTILATING AND AIR CONDITIONING
LCP	LOCAL CONTROL PANEL
LOR	LOCAL-OFF-REMOTE
LR	LOCAL-REMOTE
MA	MANUAL-AUTO
MCC	MOTOR CONTROL CENTER
MFR	MANUFACTURER
MPU	MOTOR PROTECTION UNIT
OC	OPEN-CLOSE (D)
OCA	OPEN-CLOSE-AUTO
OO	ON-OFF
OOA	ON-OFF-AUTO
OOR	ON-OFF-REMOTE
OSC	OPEN-STOP-CLOSE
PF	PULSE FREQUENCY
pH	HYDROGEN ION CONCENTRATION
PLC	PROGRAMMABLE LOGIC CONTROLLER
PWR	POWER
SS	START-STOP
SSRVS	SOLID STATE REDUCED VOLTAGE STARTER
RIO	REMOTE IO PNL
TYP	TYPICAL
UPS	UNINTERRUPTIBLE POWER SUPPLY
VIB	VIBRATION

NOTES

1. THIS IS A STANDARD LEGEND, THEREFORE NOT ALL OF THIS INFORMATION MAY BE USED ON THIS PROJECT.
2. COMPONENTS AND PANELS SHOWN WITH A () ARE SPECIFIED UNDER SECTION PROCESS INSTRUMENTATION AND CONTROL SYSTEM.
3. COMPONENTS AND PANELS SHOWN WITH ONE OR MORE ASTERISKS ARE PART OF A PACKAGE SYSTEM, SEE EQUIPMENT SPECIFICATIONS.

SELF CONTAINED VALVE & EQUIPMENT TAG NAMING

ARV	AIR RELEASE VALVE
BFV	BUTTERFLY VALVE
CFP	CHEMICAL FEED PUMP
CP	CENTRIFUGAL PUMP
CS	COARSE SCREEN
EQP	EQUALIZATION PUMP
FCV	FLOW CONTROL VALVE
FS	FINE SCREEN
G	GATE
LCV	LEVEL CONTROL VALVE
M	MECHANICAL EQUIPMENT
P	PUMP
PCP	PROGRESSIVE CAVITY PUMP
PRV	PRESSURE RELIEF VALVE
PWP	POTABLE WATER PUMP
SGA	SLIDE GATE ACTUATOR
T	TANK
VTP	VERTICAL TURBINE PUMP
WP	WELL PUMP
WW	= PROCESS NUMBER
Y	= LOOP NUMBER
Z	= UNIT NUMBER

FLOW STREAM IDENTIFICATION

UW	UTILITY WATER
LPA	LOW PRESSURE AIR
BD	BACKDRAIN
CA	CITRIC ACID
FA	FOUL AIR
FE	FINAL EFFLUENT
INF	INFLUENT
IA	INSTRUMENT AIR
PRM	PERMEATE
PW	POTABLE WATER
PDF	PROCESS DRAIN (FORCE MAIN)
PD	PROCESS DRAIN (GRAVITY)
RW	RECYCLED WATER
RAS	RETURN ACTIVATED SLUDGE
SD	STORM DRAIN
SH	SODIUM HYPOCHLORITE
CS	SODIUM HYDROXIDE
SL	SLUDGE
WW	WASTEWATER
WWF	WASTEWATER (FORCEMAIN)
WAS	WASTE ACTIVATED SLUDGE

INTERFACE SYMBOLS & LINE LEGEND

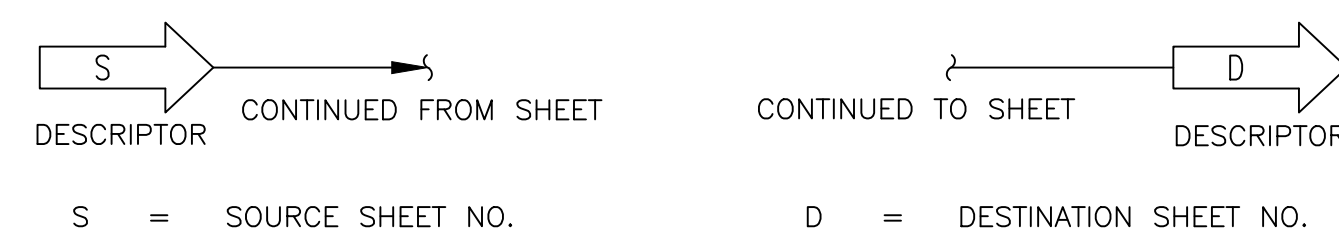
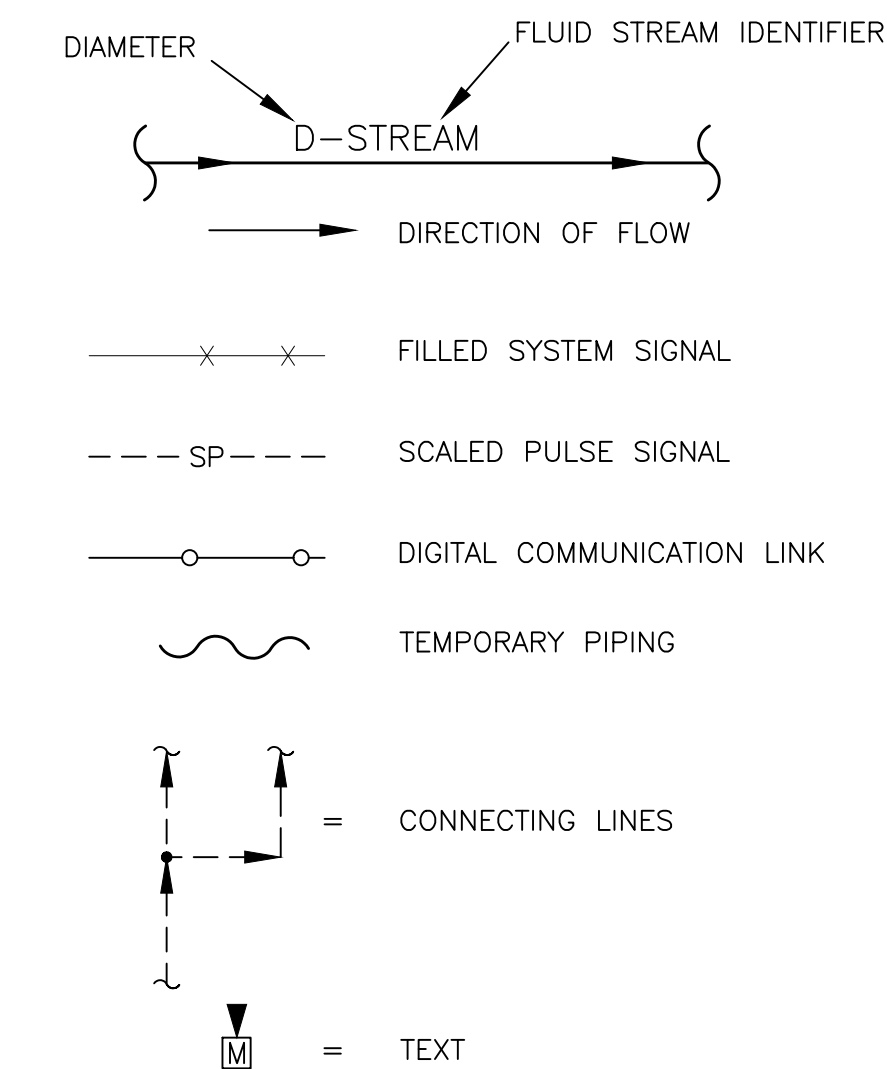

INPUT/OUTPUT INTERFACE SYMBOLS

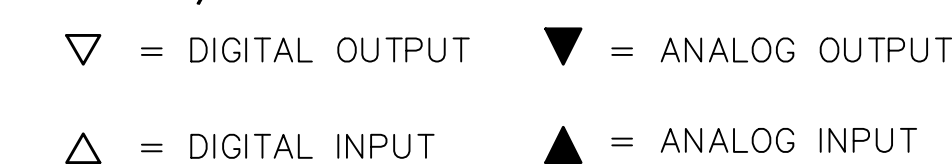

DESIGNED: JCC

DRAWN: PMD

CHECKED: MNR

SCALE: NO SCALE

PREPARED BY:

JOHN CALTON, PE

No.: E 14099

Exp.: 6-30-25

No.: E14099

DATE

POSITION

DATE

DATE

DATE



805 AEROVISTA PLACE, SUITE 201 SAN LUIS OBISPO, CA 93401
PHONE: (805) 457-8833 FAX: (805) 888-2764

HERITAGE RANCH COMMUNITY SERVICES DISTRICT
4870 HERITAGE ROAD
PASO ROBLES, CA 93446

APPROVED: _____ POSITION _____ DATE _____

WATER RESOURCE RECOVERY FACILITY UPGRADE
INSTRUMENTATION

INSTRUMENTATION LEGENDS, ABBREVIATIONS, AND NOTES

DRAWING
00-N001

SHEET X OF X
PROJECT # _____

DRAFT - NOT FOR CONSTRUCTION

W:\3.0 Clients\Heritage Ranch Community Services District\1029\10090 WRF Upgrade Design\6.0 Working Files\0-CAD\1-SHEET FILES\G-HRCSO-WWTP - Instru.dwg 11/10/2023 2:50 PM Chris Durbin

W:\3.0 Clients\Heritage Ranch Community Services District\1029\10090 WRF Upgrade Design\6.0 Working Files\CAD\1-SHEET FILES\G-HRCSO-WWTP - Instru.dwg 11/10/2023 2:55 PM Chris Durbin

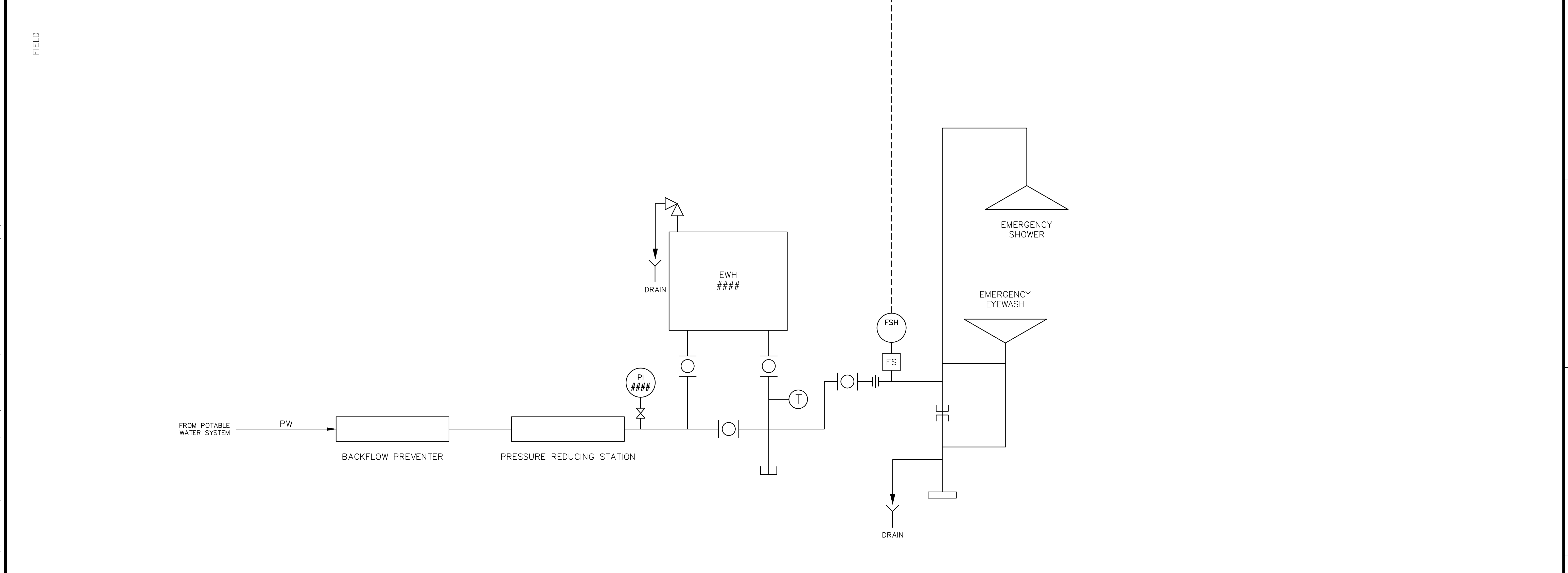
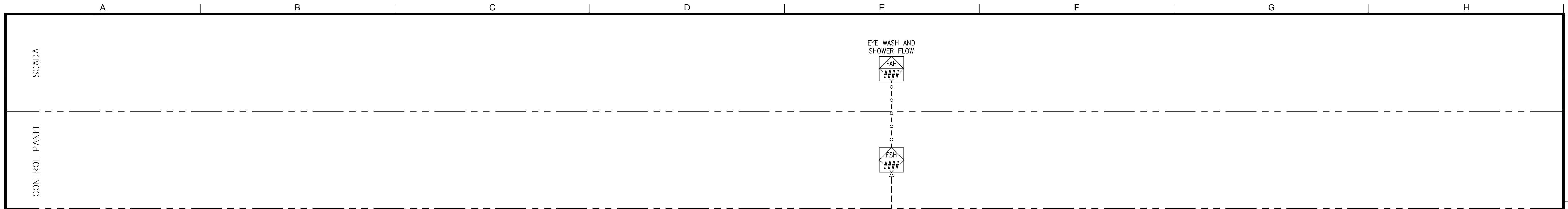

LOCATION	EWH TAG NUMBER	FS TAG NUMBER	PI TAG NUMBER	PW PIPE SIZE	EQUIPMENT
MEMBRANE BIOREACTOR	0401	0401	0401	1"	EYEWASH ONLY
CHEMICAL STORAGE AREA	0501	0501	0501	1.5"	EYEWASH AND SHOWER
DEWATERING	0601	0601	0601	1"	EYEWASH ONLY

DRAFT - NOT FOR CONSTRUCTION

REV	DATE	BY	DESCRIPTION

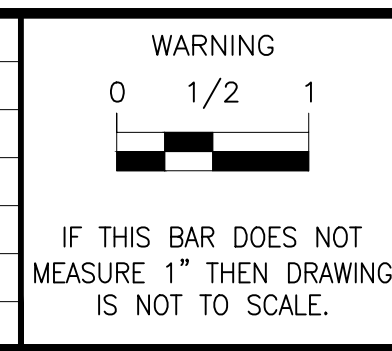

DESIGNED	JCC
DRAWN	PMD
CHECKED	MNR
SCALE	NO SCALE

PREPARED BY:
 JOHN CALTON, PE
 No.: E14099

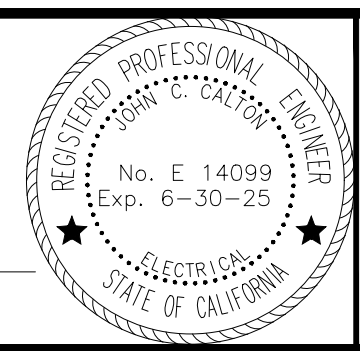

HERITAGE RANCH COMMUNITY SERVICES DISTRICT
 4870 HERITAGE ROAD
 PASO ROBLES, CA 93446

APPROVED: _____ POSITION _____ DATE _____

WATER RESOURCE RECOVERY FACILITY UPGRADE
 INSTRUMENTATION
EMERGENCY EYEWASH AND SHOWER P&ID

DRAWING
00-N601
 SHEET X OF X
 PROJECT # _____

W:\3.0 Clients\Heritage Ranch Community Services District\1029\10090 WRF Upgrade Design\6.0 Working Files\0-CAD\1-SHEET FILES\G-HRCSO-WWTP - Instru.dwg 11/10/2023 2:50 PM Chris Durbin

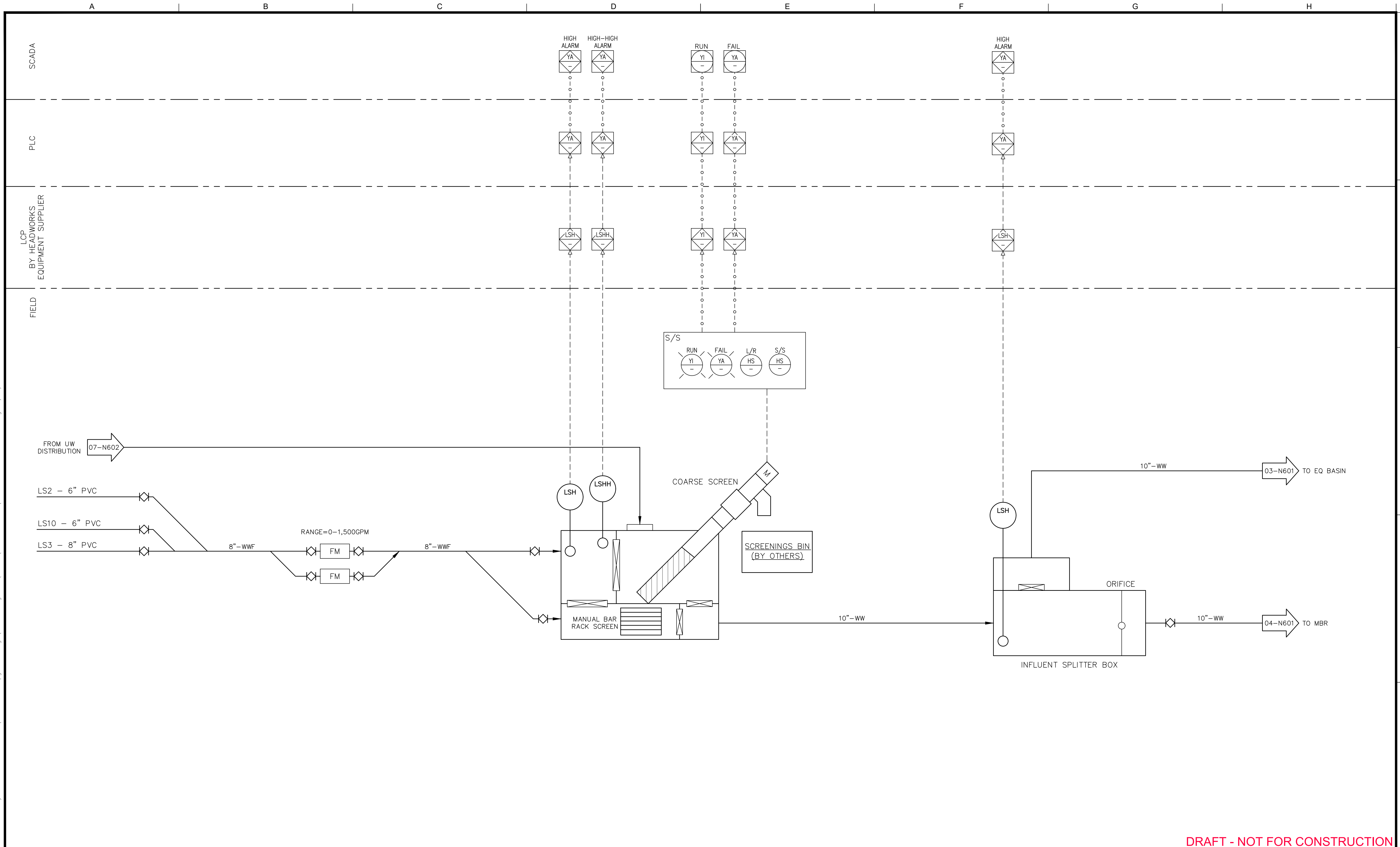

DRAFT - NOT FOR CONSTRUCTION

REV	DATE	BY	DESCRIPTION

WARNING

 IF THIS BAR DOES NOT MEASURE 1" THEN DRAWING IS NOT TO SCALE.

DESIGNED: JCC
 DRAWN: PMD
 CHECKED: MNR
 SCALE: NO SCALE

PREPARED BY:
 JOHN CALTON, PE
 No.: E14099
 DATE

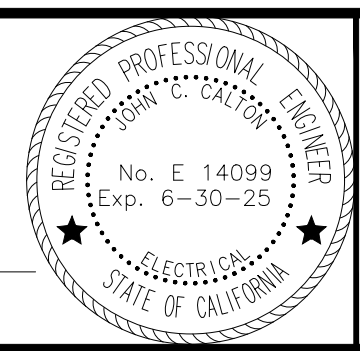

HERITAGE RANCH COMMUNITY SERVICES DISTRICT
 4870 HERITAGE ROAD
 PASO ROBLES, CA 93446

805 AEROVISTA PLACE, SUITE 201 SAN LUIS OBISPO, CA 93401
 PHONE: (805) 457-8833 FAX: (805) 888-2764

APPROVED: _____ POSITION _____ DATE _____

WATER RESOURCE RECOVERY FACILITY UPGRADE
 INSTRUMENTATION
HEADWORKS P&ID

DRAWING
02-N601
 SHEET X OF X
 PROJECT # _____

W:\3.0 Clients\Heritage Ranch Community Services District\1029\10090 WRF Upgrade Design\6.0 Working Files\CAD\1-SHEET FILES\G-HRCSO-WWTP - Instru.dwg 11/10/2023 2:50 PM Chris Durbin

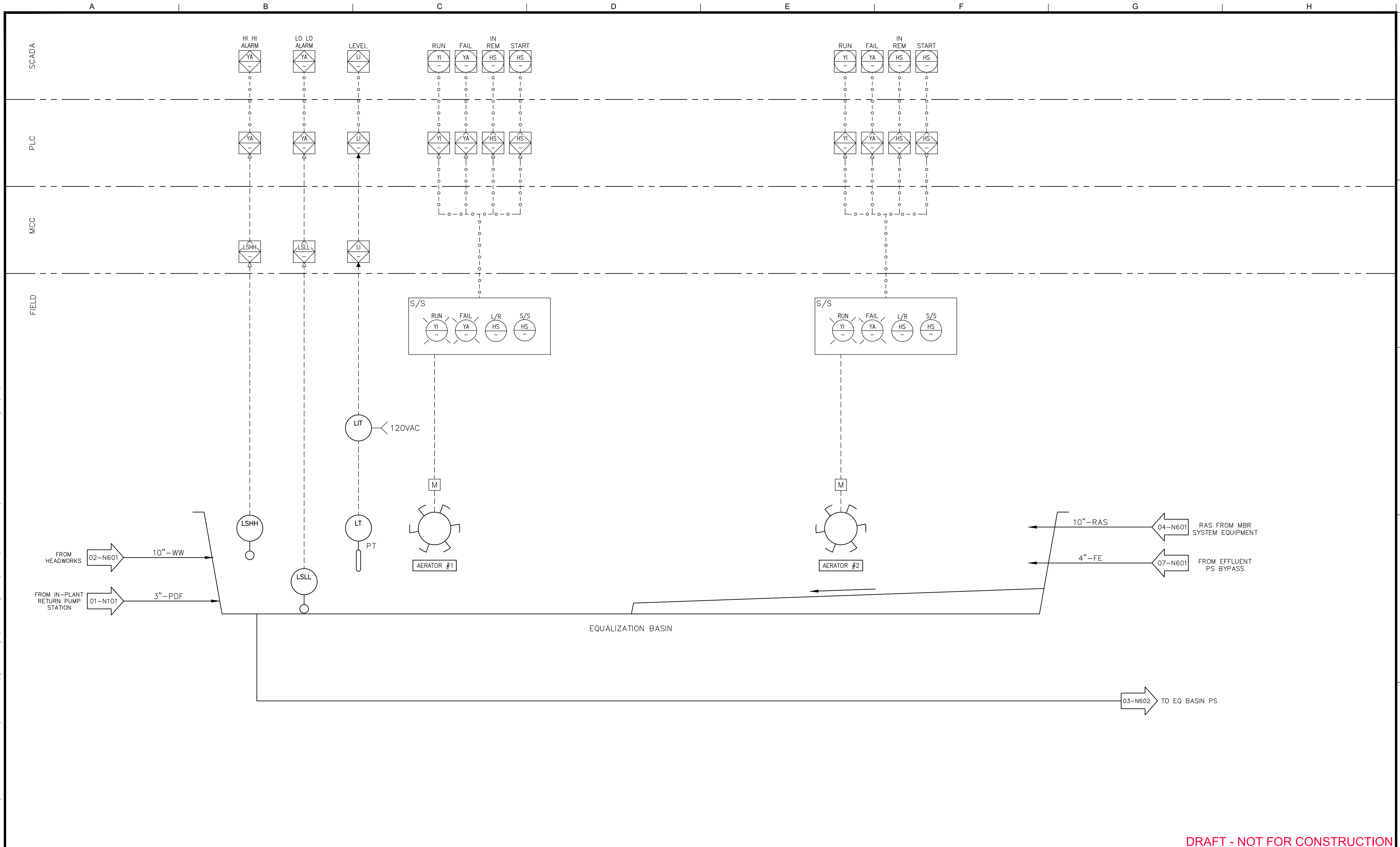

DRAFT - NOT FOR CONSTRUCTION

REV	DATE	BY	DESCRIPTION

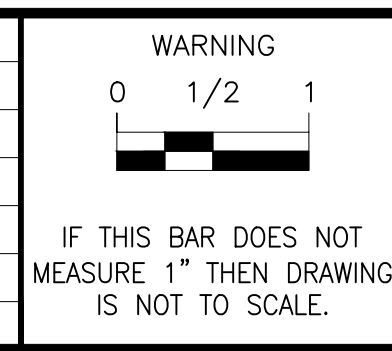

DESIGNED	JCC
DRAWN	PMD
CHECKED	MNR
SCALE	NO SCALE

PREPARED BY:
 JOHN CALTON, PE
 No.: E14099

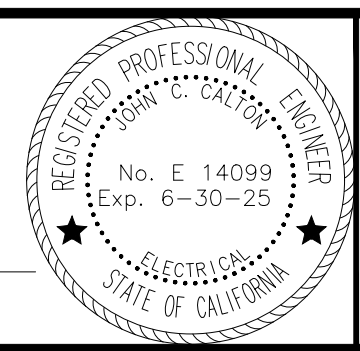

WSC
 805 AEROVISTA PLACE, SUITE 201
 PHONE: (805) 457-8833

SAN LUIS OBISPO, CA 93401
 FAX: (805) 888-2764

HERITAGE RANCH COMMUNITY SERVICES DISTRICT
 4870 HERITAGE ROAD
 PASO ROBLES, CA 93446

APPROVED: _____ POSITION _____ DATE _____

WATER RESOURCE RECOVERY FACILITY UPGRADE
 INSTRUMENTATION
**EQUALIZATION BASIN
 P&ID**

DRAWING
03-N601
 SHEET X OF X
 PROJECT # _____

W:\3.0 Clients\Heritage Ranch Community Services District\1029\10090 WRF Upgrade Design\6.0 Working Files\CAD\1-SHEET FILES\G-HRCSO-WWTP - Instrudwg 11/10/2023 2:50 PM Chris Durbin

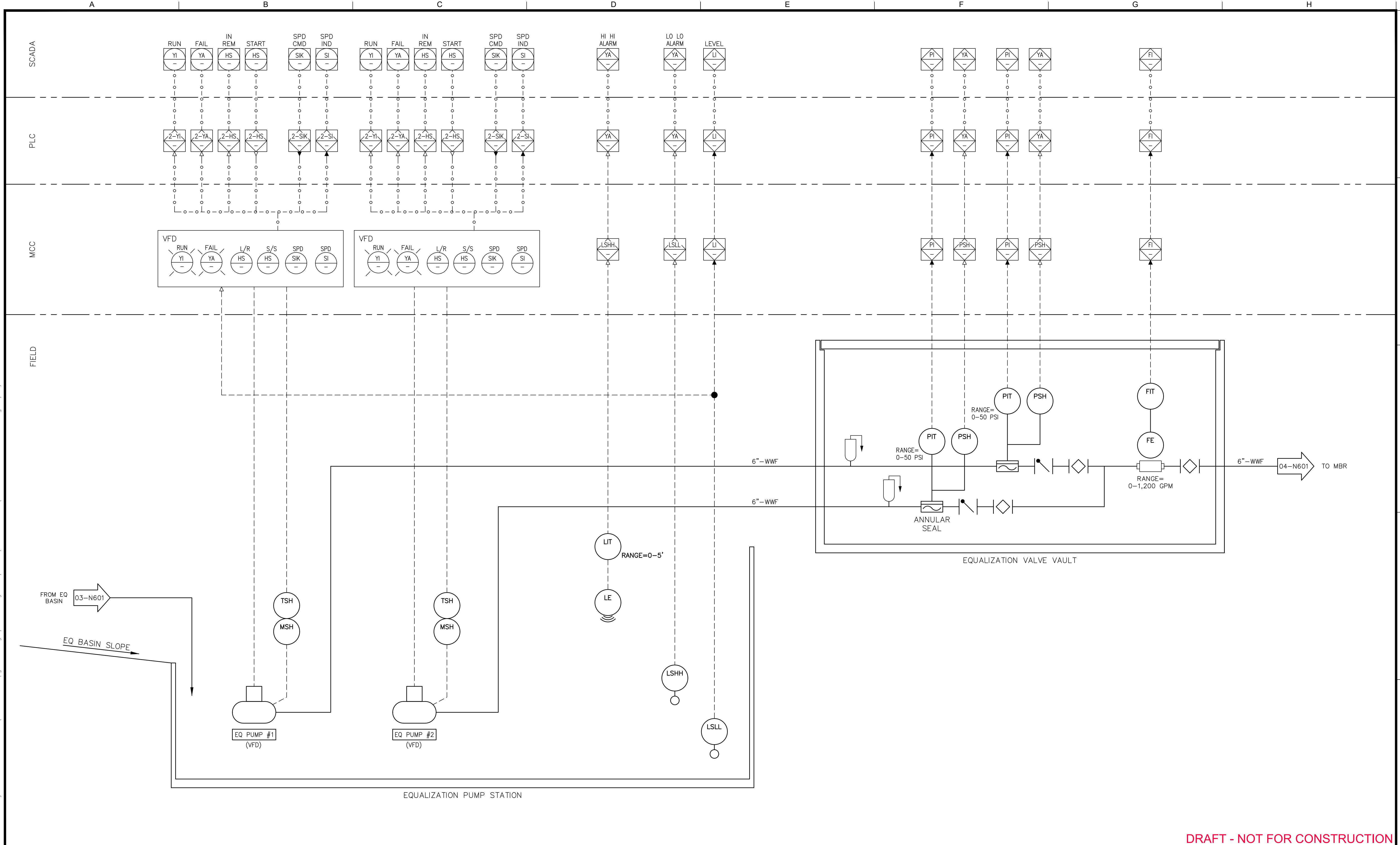

DRAFT - NOT FOR CONSTRUCTION

REV	DATE	BY	DESCRIPTION

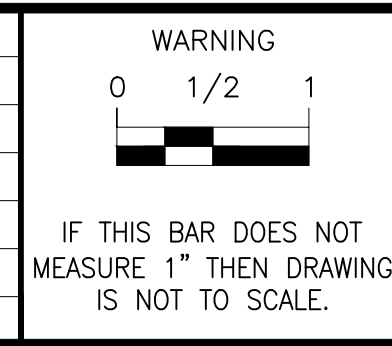

DESIGNED: JCC
 DRAWN: PMD
 CHECKED: MNR
 SCALE: NO SCALE

PREPARED BY:
 JOHN CALTON, PE
 No. E14099
 Exp. 6-30-25
 DATE



HERITAGE RANCH COMMUNITY SERVICES DISTRICT
 4870 HERITAGE ROAD
 PASO ROBLES, CA 93446

805 AEROVISTA PLACE, SUITE 201 SAN LUIS OBISPO, CA 93401
 PHONE: (805) 457-8833 FAX: (805) 888-2764

APPROVED: _____ POSITION _____ DATE _____

WATER RESOURCE RECOVERY FACILITY UPGRADE
 INSTRUMENTATION
**EQUALIZATION BASIN PUMP STATION
 P&ID**

DRAWING
03-N602
 SHEET X OF X
 PROJECT # _____

W:\3.0 Clients\Heritage Ranch Community Services District\1029\10090 WRF Upgrade Design\6.0 Working Files\0-CAD\1-SHEET FILES\G-HRCSO-WWTP - Instrudwg 11/10/2023 2:50 PM Chris Durbin

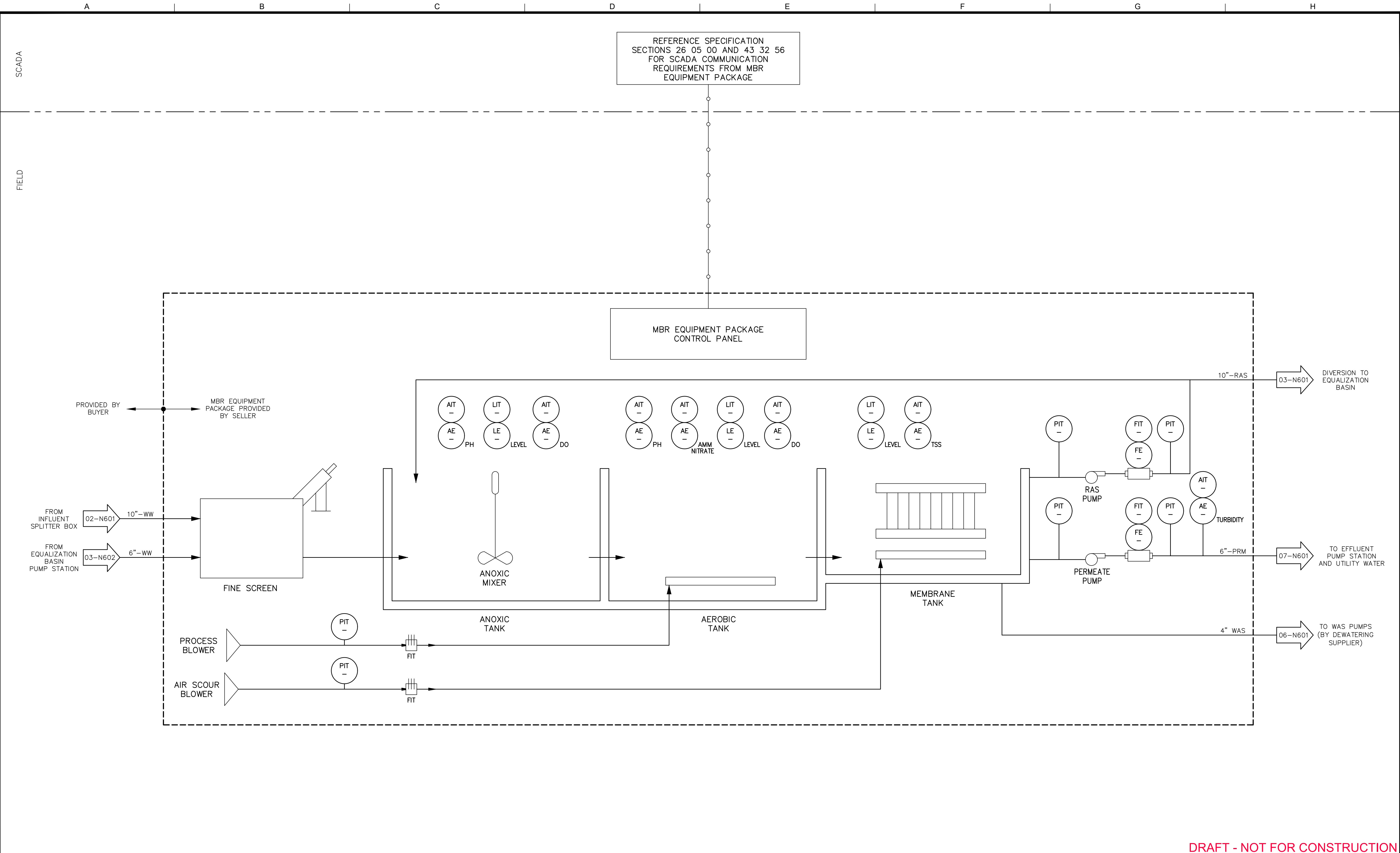

DRAFT - NOT FOR CONSTRUCTION

REV	DATE	BY	DESCRIPTION

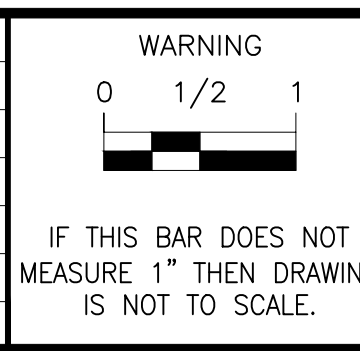

DESIGNED	JCC
DRAWN	PMD
CHECKED	MNR
SCALE	NO SCALE

PREPARED BY:

JOHN CALTON, PE
No.: E14099

DATE

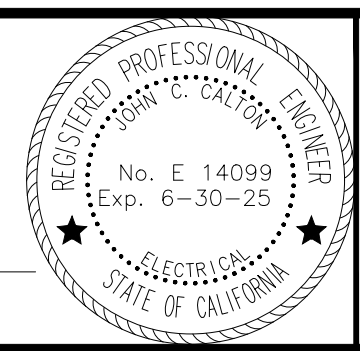

HERITAGE RANCH COMMUNITY SERVICES DISTRICT
4870 HERITAGE ROAD
PASO ROBLES, CA 93446

805 AEROVISTA PLACE, SUITE 201 SAN LUIS OBISPO, CA 93401
PHONE: (805) 457-8833 FAX: (805) 888-2764

APPROVED:

_____ POSITION _____ DATE _____

WATER RESOURCE RECOVERY FACILITY UPGRADE

INSTRUMENTATION

REPRESENTATIVE MBR EQUIPMENT
PACKAGE P&ID

DRAWING

04-N601

SHEET X OF X
PROJECT # _____

W:\3.0 Clients\Heritage Ranch Community Services District\1029\10090 WRF Upgrade Design\6.0 Working Files\0-CAD\1-SHEET FILES\G-HRCSO-WWTP - Instrudwg 11/10/2023 2:50 PM Chris Durbin

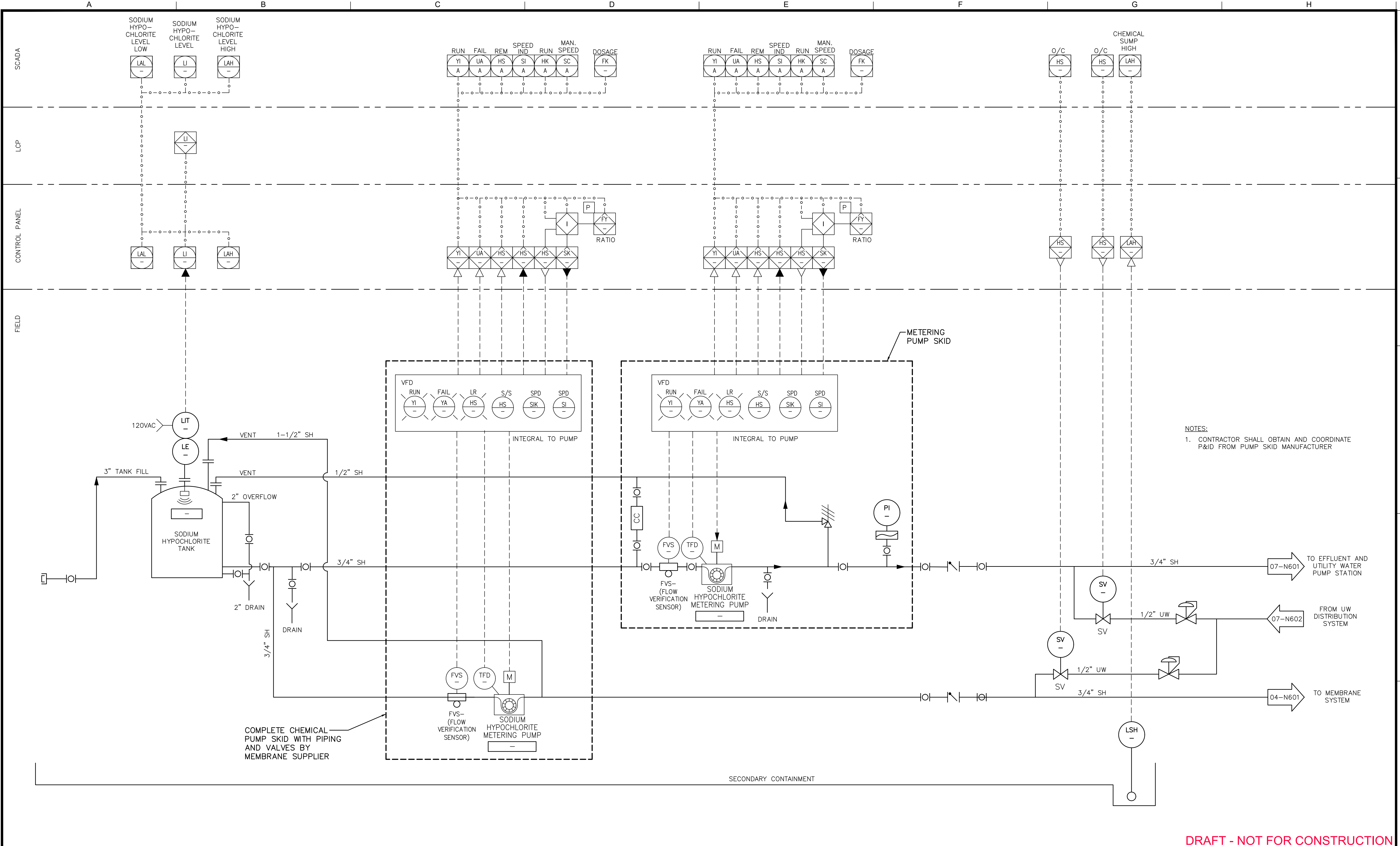

NOTES:
1. CONTRACTOR SHALL OBTAIN AND COORDINATE P&ID FROM PUMP SKID MANUFACTURER

DRAFT - NOT FOR CONSTRUCTION

REV	DATE	BY	DESCRIPTION

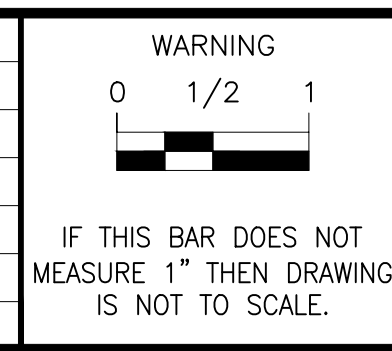

DESIGNED	JCC
DRAWN	PMD
CHECKED	MNR
SCALE	NO SCALE

PREPARED BY:
JOHN CALTON, PE
No.: E14099
Exp: 6-30-25
DATE

WSC
HERITAGE RANCH COMMUNITY SERVICES DISTRICT
4870 HERITAGE ROAD
PASO ROBLES, CA 93446
805 AEROVISTA PLACE, SUITE 201 SAN LUIS OBISPO, CA 93401
PHONE: (805) 457-8833 FAX: (805) 888-2764

APPROVED: _____ POSITION _____ DATE _____

WATER RESOURCE RECOVERY FACILITY UPGRADE
INSTRUMENTATION
**CHEMICAL STORAGE AREA SYSTEM
P&ID 1**

DRAWING
05-N601
SHEET X OF X
PROJECT # _____

W:\3.0 Clients\Heritage Ranch Community Services District\1029\10090 WRF Upgrade Design\6.0 Working Files\0-CAD\1-SHEET FILES\G-HRCSO-WWTP - Instrudwg 11/10/2023 2:50 PM Chris Durbin

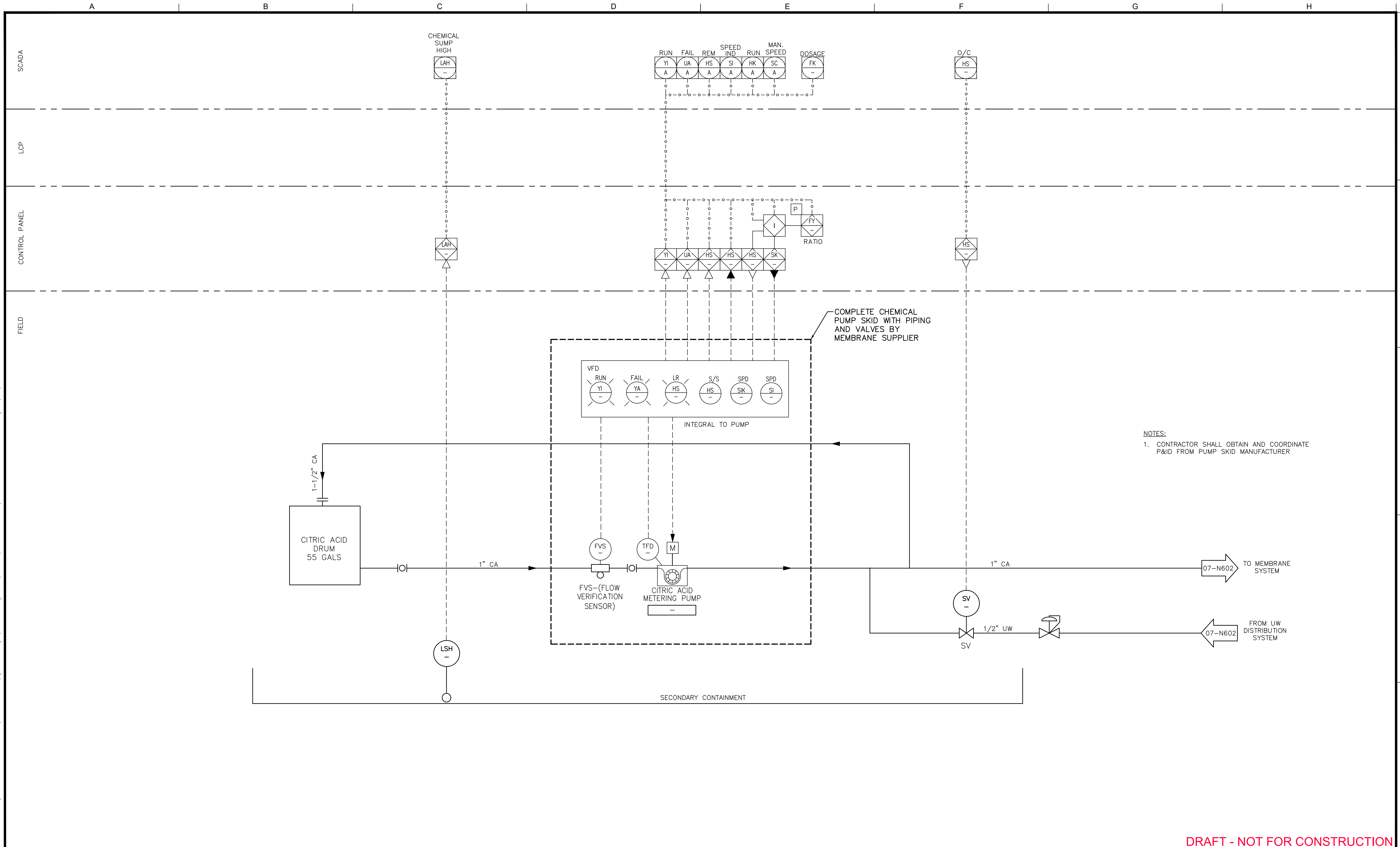

NOTES:
 1. CONTRACTOR SHALL OBTAIN AND COORDINATE P&ID FROM PUMP SKID MANUFACTURER

DRAFT - NOT FOR CONSTRUCTION

REV	DATE	BY	DESCRIPTION

WARNING
 0 1/2 1
 IF THIS BAR DOES NOT MEASURE 1" THEN DRAWING IS NOT TO SCALE.

DESIGNED: JCC
 DRAWN: PMD
 CHECKED: MNR
 SCALE: NO SCALE

PREPARED BY:
 JOHN CALTON, PE
 No.: E14099
 DATE

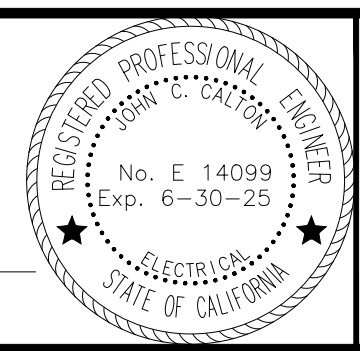

HERITAGE RANCH COMMUNITY SERVICES DISTRICT
 4870 HERITAGE ROAD
 PASO ROBLES, CA 93446

805 AEROVISTA PLACE, SUITE 201 SAN LUIS OBISPO, CA 93401
 PHONE: (805) 457-8833 FAX: (805) 888-2764

APPROVED:
 _____ POSITION
 _____ DATE

WATER RESOURCE RECOVERY FACILITY UPGRADE
 INSTRUMENTATION
**CHEMICAL STORAGE AREA SYSTEM
 P&ID 2**

DRAWING
05-N602
 SHEET X OF X
 PROJECT #

W:\3.0 Clients\Heritage Ranch Community Services District 1029\10090 WRF Upgrade Design\6.0 Working Files\CAD\1-SHEET FILES\G-HRCSO-WWTP - Instrudwg 11/10/2023 2:50 PM Chris Durbin

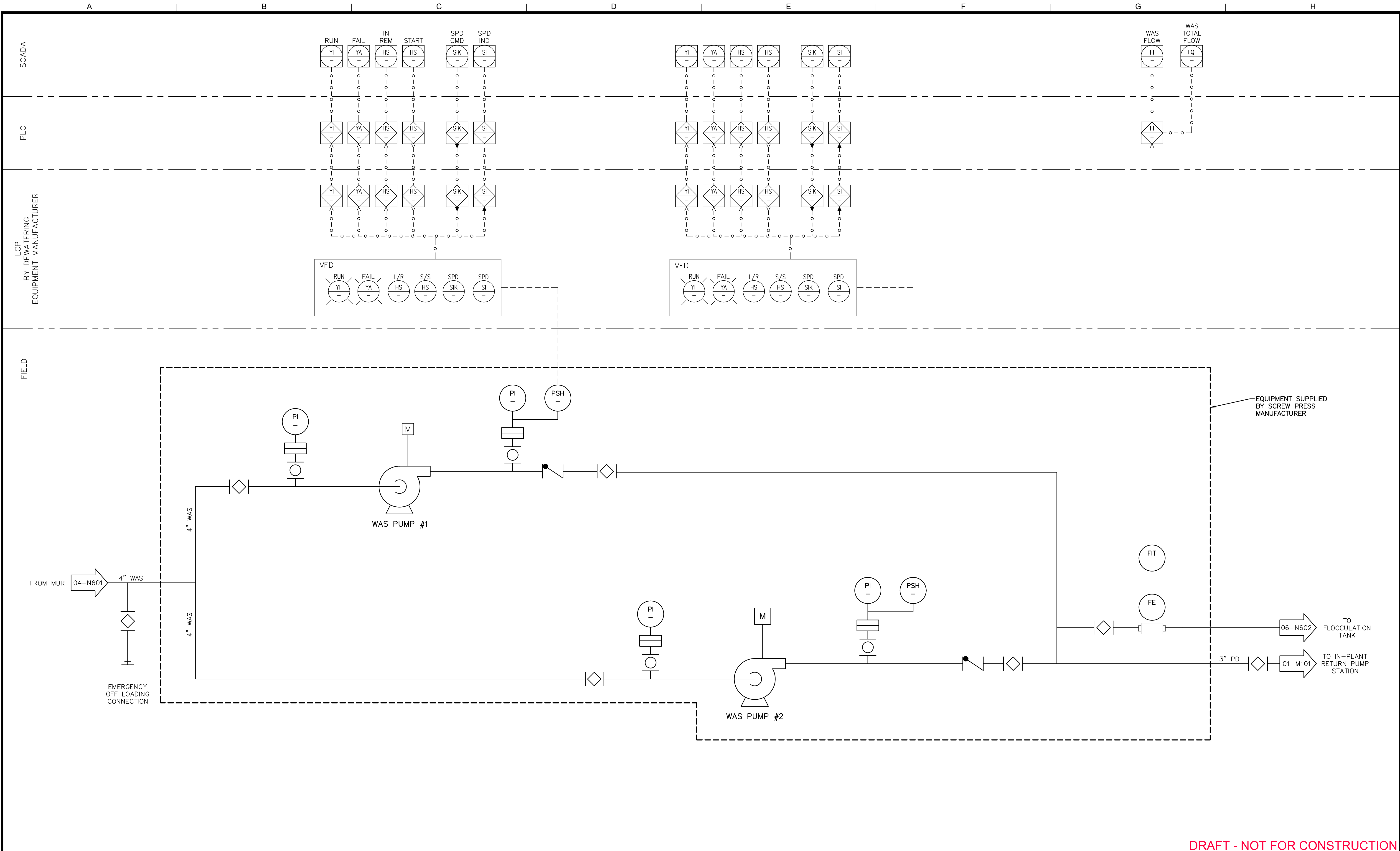

DRAFT - NOT FOR CONSTRUCTION

REV	DATE	BY	DESCRIPTION

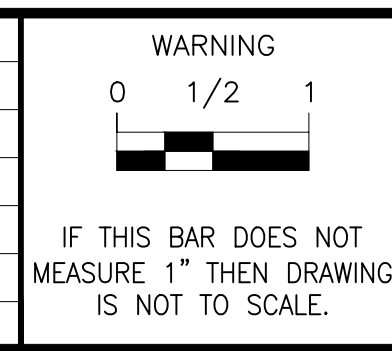

DESIGNED	JCC
DRAWN	PMD
CHECKED	MNR
SCALE	NO SCALE

PREPARED BY:
 JOHN CALTON, PE
 No.: E14099
 Exp.: 6-30-25
 DATE



HERITAGE RANCH COMMUNITY SERVICES DISTRICT
 4870 HERITAGE ROAD
 PASO ROBLES, CA 93446

APPROVED: _____ POSITION _____ DATE _____

WATER RESOURCE RECOVERY FACILITY UPGRADE
 INSTRUMENTATION
**DEWATERING SCREW PRESS SYSTEM
 P&ID 1**

DRAWING
06-N601
 SHEET X OF X
 PROJECT # _____

W:\3.0 Clients\Heritage Ranch Community Services District\1029\10090 WRF Upgrade Design\6.0 Working Files\0-CAD\1-SHEET FILES\G-HRCSO-WWTP - Instru.dwg 11/10/2023 2:50 PM Chris Durbin

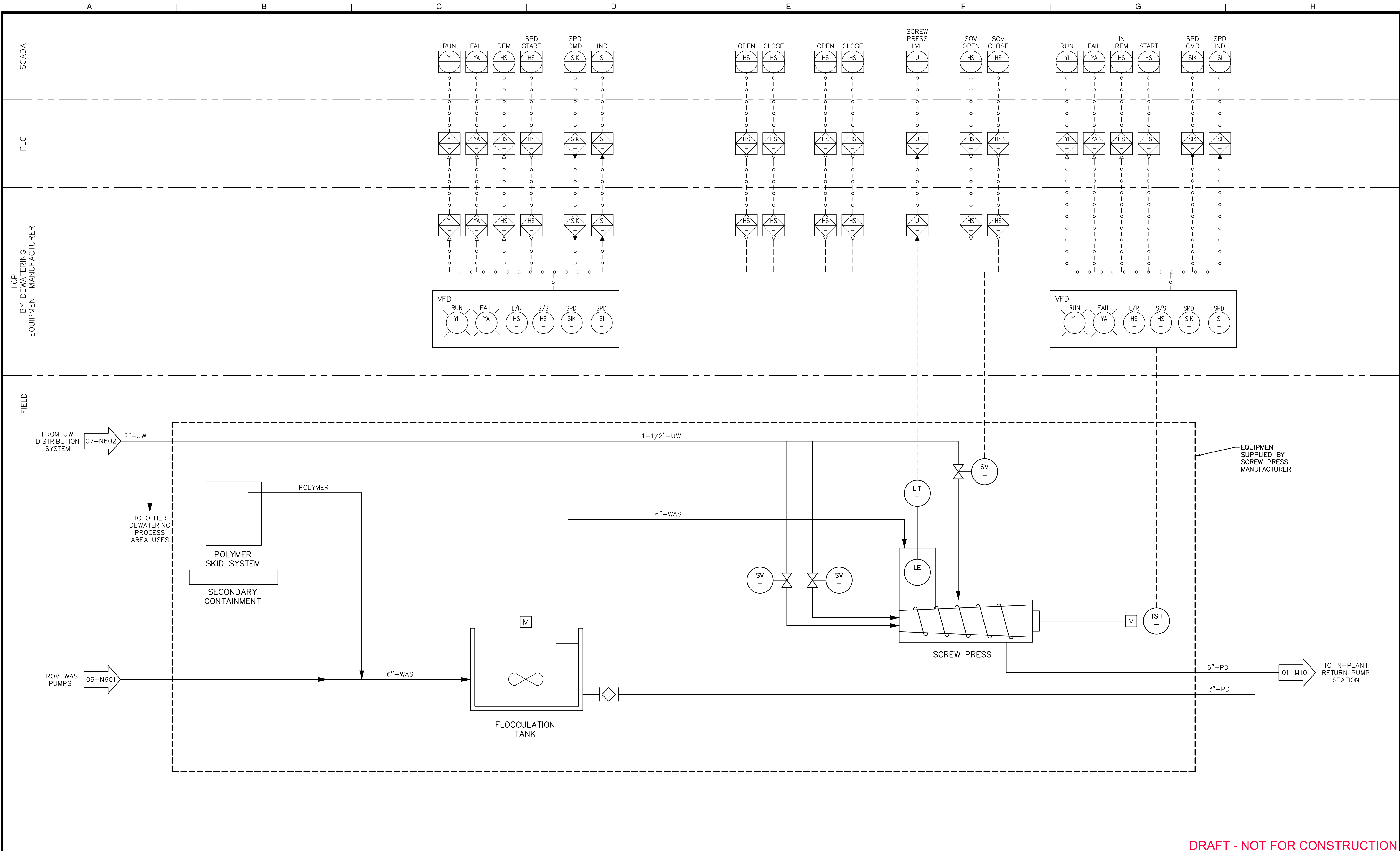

DRAFT - NOT FOR CONSTRUCTION

REV	DATE	BY	DESCRIPTION

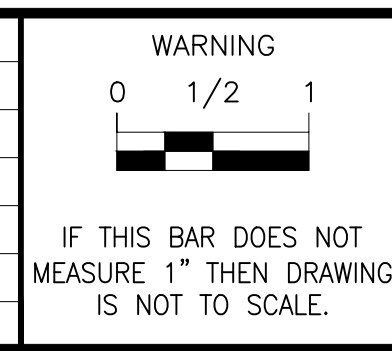

DESIGNED	JCC
DRAWN	PMD
CHECKED	MNR
SCALE	NO SCALE

PREPARED BY:

JOHN CALTON, PE
No.: E14099
Exp.: 6-30-25

DATE

HERITAGE RANCH COMMUNITY SERVICES DISTRICT
4870 HERITAGE ROAD
PASO ROBLES, CA 93446

805 AEROVISTA PLACE, SUITE 201
PHONE: (805) 457-8833

SAN LUIS OBISPO, CA 93401
FAX: (805) 888-2764

APPROVED:

----- POSITION

DATE

WATER RESOURCE RECOVERY FACILITY UPGRADE
INSTRUMENTATION
DEWATERING SCREW PRESS SYSTEM
P&ID 2

DRAWING

06-N602

SHEET X OF X

PROJECT #

W:\3.0 Clients\Heritage Ranch Community Services District\1029\10090 WRF Upgrade Design\6.0 Working Files\CAD\1-SHEET FILES\G-HRCSO-WWTP - Instrudwg 11/10/2023 2:50 PM Chris Durbin

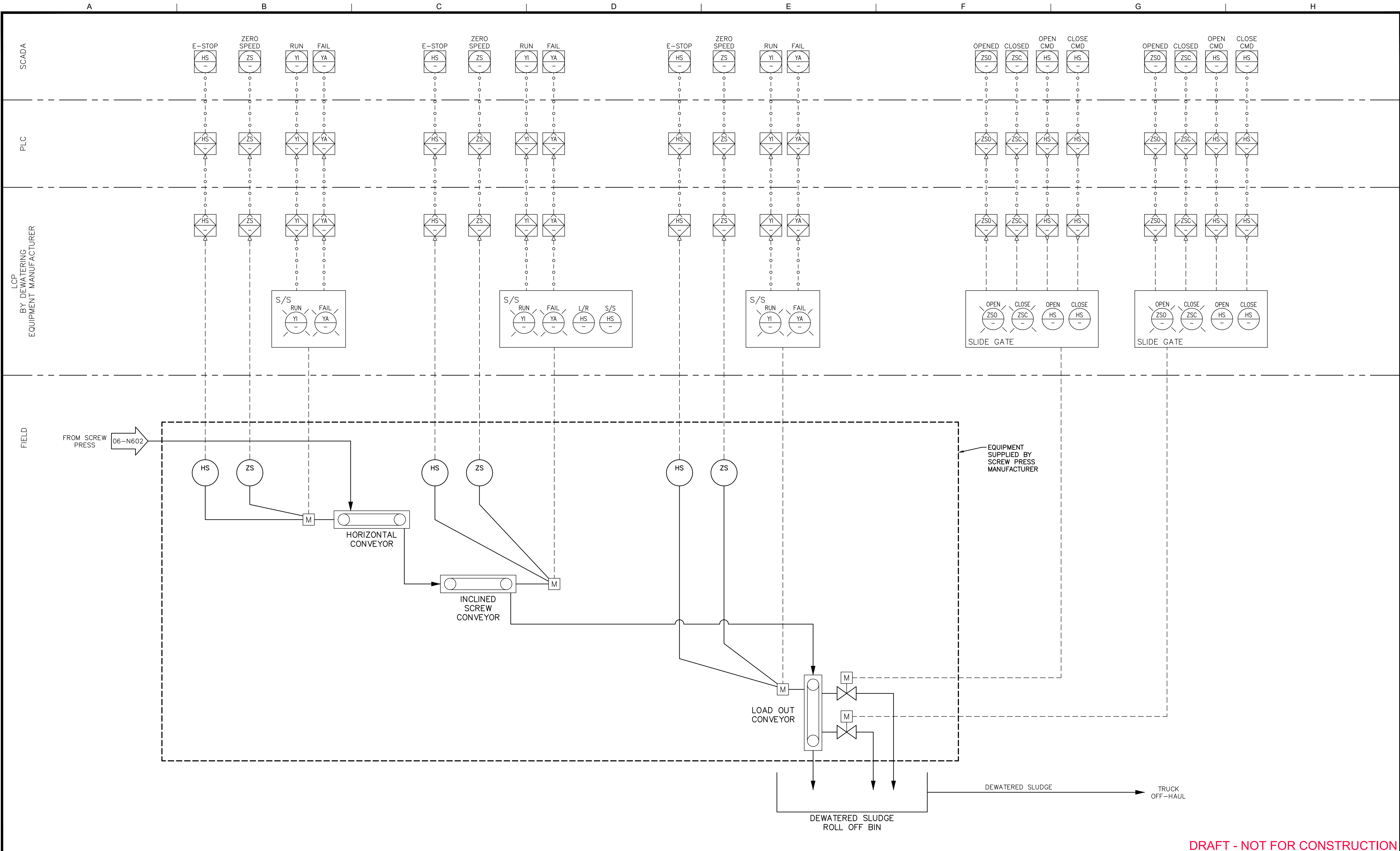

DRAFT - NOT FOR CONSTRUCTION

REV	DATE	BY	DESCRIPTION

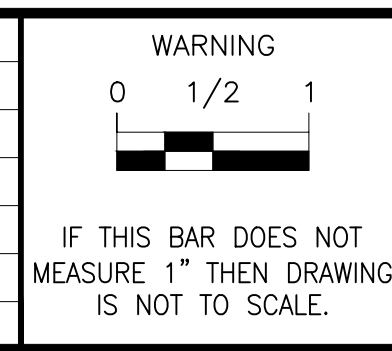

DESIGNED	JCC
DRAWN	PMD
CHECKED	MNR
SCALE	NO SCALE

PREPARED BY:

JOHN CALTON, PE
No.: E14099
Exp.: 6-30-25

DATE

HERITAGE RANCH COMMUNITY SERVICES DISTRICT
4870 HERITAGE ROAD
PASO ROBLES, CA 93446

805 AEROVISTA PLACE, SUITE 201
PHONE: (805) 457-8833

SAN LUIS OBISPO, CA 93401
FAX: (805) 888-2764

APPROVED:

POSITION

DATE

WATER RESOURCE RECOVERY FACILITY UPGRADE
INSTRUMENTATION
DEWATERING SCREW PRESS SYSTEM
P&ID 3

DRAWING

06-N603

SHEET X OF X

PROJECT #

W:\3.0 Clients\Heritage Ranch Community Services District\1029\10090 WRF Upgrade Design\6.0 Working Files\0-CAD\1-SHEET FILES\G-HRCSO-WWTP - Instrudwg 11/10/2023 2:50 PM Chris Durbin

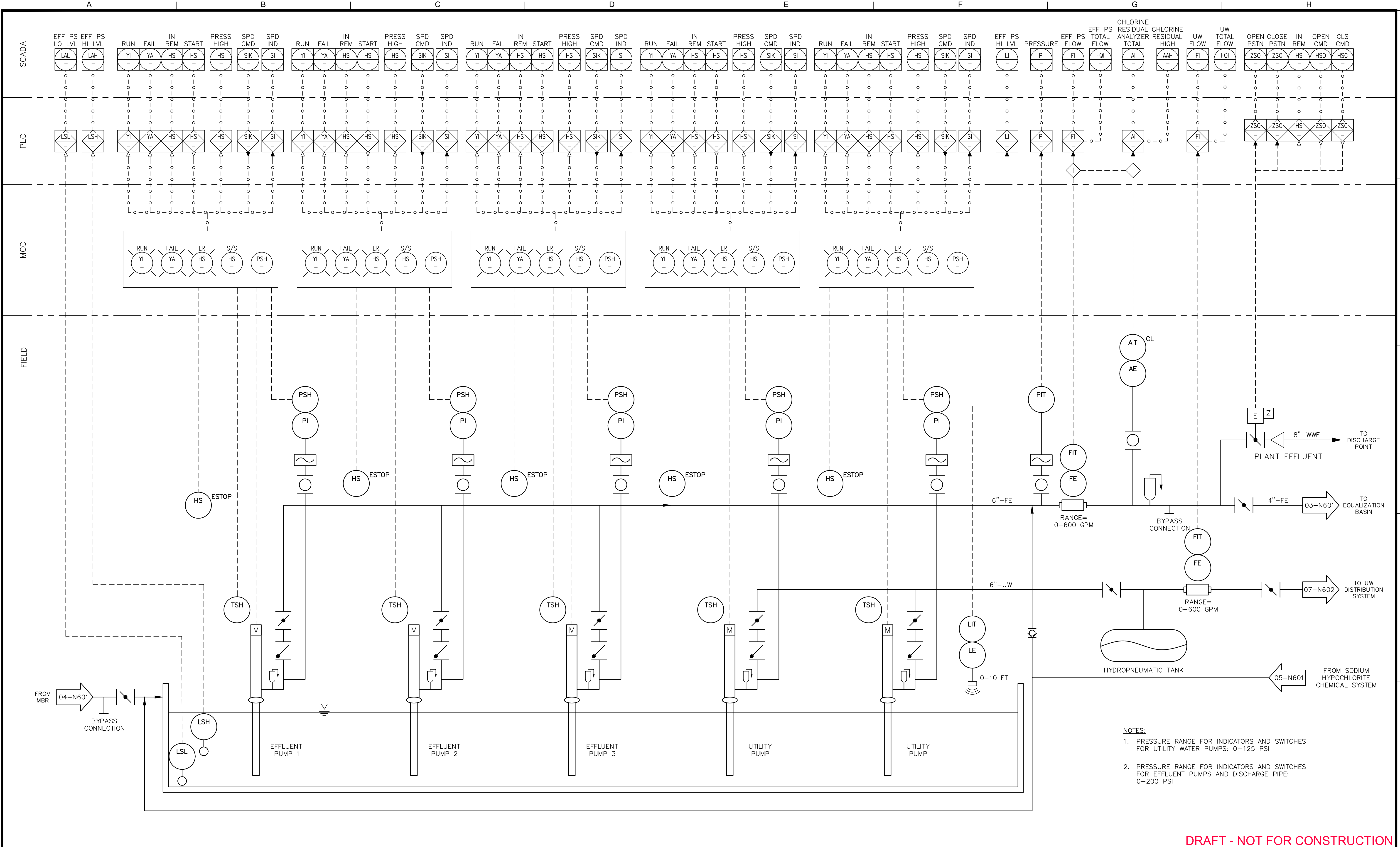

- NOTES:**
- PRESSURE RANGE FOR INDICATORS AND SWITCHES FOR UTILITY WATER PUMPS: 0-125 PSI
 - PRESSURE RANGE FOR INDICATORS AND SWITCHES FOR EFFLUENT PUMPS AND DISCHARGE PIPE: 0-200 PSI

DRAFT - NOT FOR CONSTRUCTION

REV	DATE	BY	DESCRIPTION

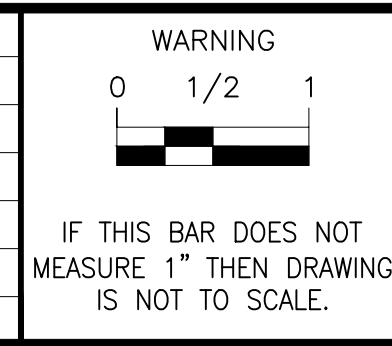

DESIGNED: JCC
 DRAWN: PMD
 CHECKED: MNR
 SCALE: NO SCALE

PREPARED BY:
 JOHN CALTON, PE
 No. E 14099
 Exp. 6-30-25
 STATE OF CALIFORNIA
 REGISTERED PROFESSIONAL ENGINEER - ELECTRICAL

WSC
 805 AEROVISTA PLACE, SUITE 201
 PHONE: (805) 457-8833
 SAN LUIS OBISPO, CA 93401
 FAX: (805) 888-2764

HERITAGE RANCH COMMUNITY SERVICES DISTRICT
 4870 HERITAGE ROAD
 PASO ROBLES, CA 93446

APPROVED: _____ POSITION _____ DATE _____

WATER RESOURCE RECOVERY FACILITY UPGRADE
 INSTRUMENTATION
EFFLUENT AND UTILITY WATER PUMP STATION P&ID

DRAWING
07-N601
 SHEET X OF X
 PROJECT # _____

SCADA

NO OUTPUTS OR INPUTS

PLC

NO OUTPUTS OR INPUTS

MCC

NO OUTPUTS OR INPUTS

FIELD

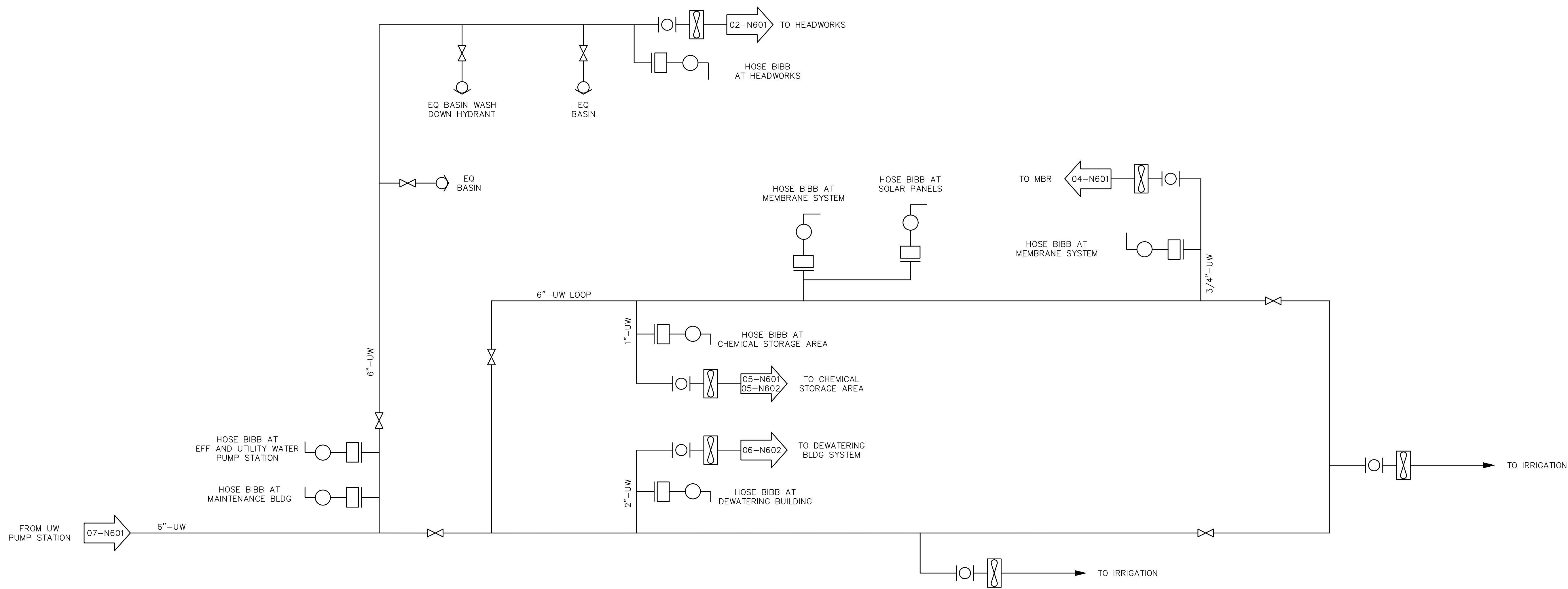

DRAFT - NOT FOR CONSTRUCTION

W:\3.0 Clients\Heritage Ranch Community Services District\1029\10090 WRF Upgrade Design\6.0 Working Files\0-CAD\1-SHEET FILES\G-HRCSO-WWTP - Instru.dwg 11/10/2023 2:50 PM Chris Durbin

REV	DATE	BY	DESCRIPTION

WARNING

IF THIS BAR DOES NOT MEASURE 1" THEN DRAWING IS NOT TO SCALE.

DESIGNED: JCC
 DRAWN: PMD
 CHECKED: MNR
 SCALE: NO SCALE

PREPARED BY:
 JOHN CALTON, PE
 No.: E14099
 DATE



HERITAGE RANCH COMMUNITY SERVICES DISTRICT
 4870 HERITAGE ROAD
 PASO ROBLES, CA 93446

805 AEROVISTA PLACE, SUITE 201 SAN LUIS OBISPO, CA 93401
 PHONE: (805) 457-8833 FAX: (805) 888-2764

APPROVED: _____ POSITION _____ DATE _____

WATER RESOURCE RECOVERY FACILITY UPGRADE
 INSTRUMENTATION
UTILITY WATER DISTRIBUTION SYSTEM P&ID

DRAWING
07-N602
 SHEET X OF X
 PROJECT # _____

CAPITAL COST		
Cost Item	Cost Basis	Nov 2023 Dollars
Sitework	LS	\$ 1,420,500
In-Plant Return Pump Station	LS	\$ 208,000
Headworks	LS	\$ 520,000
Influent Splitter Box	LS	\$ 63,000
Equalization Basin and Pump Station	LS	\$ 1,301,000
Packaged MBR System	LS	\$ 5,454,100
Chemical Storage Area	LS	\$ 482,000
Dewatering System	LS	\$ 1,044,300
Effluent and Utility Water Pump Station	LS	\$ 1,047,000
Electrical, Instrumentation and Control	LS	\$ 3,580,000
Effluent Pipeline	LS	\$ 692,000
Building Retrofits	LS	\$ 108,000
	Subtotal	\$ 15,919,900
Contractor OH&P and General Conditions	18.5%	\$ 2,946,000
	Construction Cost Subtotal	\$ 18,866,000
ESDC and CM	15%	\$ 2,829,900
Construction Contingency and Unaccounted for Costs	15%	\$ 2,829,900
	Total Capital Cost	\$ 24,526,000

The cost opinion presented above is an opinion of probable construction costs for estimation purposes based on an AACE Class 2 cost estimate with an accuracy range of -15% to +20%. Costs and assumptions used are based on quotes from manufacturers, recent bid estimates and industry cost data. The cost opinion is limited to the conditions existing at issuance and is not a guaranty of actual price or cost for the project. Uncertain market conditions such as, but not limited to labor availability, availability of qualified contractors, wages, other work, market changes for materials and equipment, price escalations, force majeure events, developing bidding conditions, etc. may affect the accuracy of this estimate.

HERITAGE RANCH COMMUNITY SERVICES DISTRICT

MEMORANDUM

TO: Board of Directors

FROM: Scott Duffield, General Manager

DATE: November 16, 2023

SUBJECT: Discussion and direction regarding disinfection byproducts.

Background

The District water system is exceeding the maximum contaminant level for haloacetic acids, a disinfection byproduct. This is not an immediate health risk and you do not need to use an alternative water supply. Your Board has been updated regularly on this issue.

Discussion

Sample data

The sample data for haloacetic acids (HAA5) over the last several years is shown below. This data is for individual samples. The maximum contaminant level for HAA5 is 60 parts per billion (ppb). In the table below, "Vintake TOC" is the TOC level of the water from the vertical intake; "RW TOC" is the TOC reading for Raw Water; "TW TOC" is the TOC reading for Treated Water; and "GAC Effluent" shows the TOC reading after the GAC vessels and before chlorination.

The reportable data required by the Division of Drinking Water is the Locational Running Annual Average (LRAA) by calendar quarter. The most recent LRAA for HAA5 is 76 ppb at the Black Horse Lane sample site and 71 ppb at the Wood Duck Lane sample site. We continue to send quarterly notices to customers until such a time we are under the maximum contaminant level.

HAA5 results for the last three consecutive months have been within the limits as also seen in the following table and graph.

TOC	Q1 2021	Q2	Q3	Q4	Q1 2022	Q2	Q3	Q4	Q1 2023		Q2 2023			Q3 2023			Q4 2023		
Vintake TOC						2.6	2.6			2.4	2.9	2.6	2.3	2.5	2.3	2.4	2.2	2.2	
RW TOC	3.6		3.9	5	4.6	3.9	3.9	4.3	3.7	3.0	4.0	2.6	3.2	3.3	3.0	3.0	2.9	3.0	
TW TOC	3.9		2.1	2.8	2.8	2.9	2.7	2.9	2.1	2.4	2.4	2.3	2.2	1.9	2.2	2.1	1.7	1.9	
GAC Effluent														0.9	2.0	1.8	1.8	1.9	

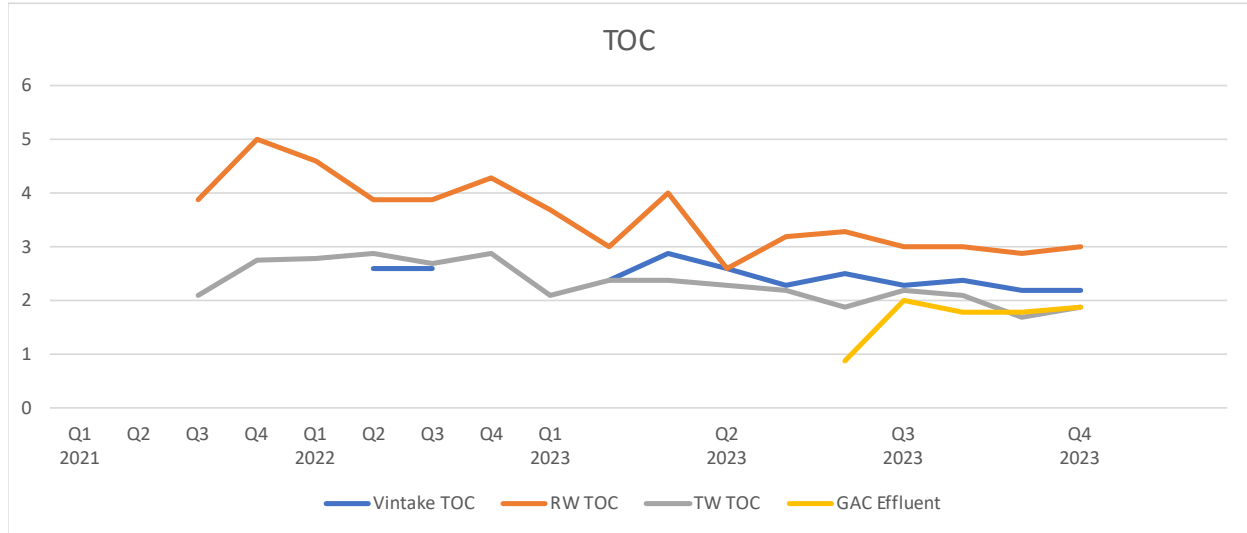

HAA5	Q1 2021	Q2	Q3	Q4	Q1 2022	Q2	Q3	Q4	Q1 2023		Q2 2023			Q3 2023			Q4 2023		
Clear Well		19	47	24	43	53	38	38	34	24	24	34	35	28	21	33	28	16	19
Wood Duck		53	95	50	51	100	130	91	100	67	66	64	64	81	46	83	50	30	31
Black Horse		43	99	81	59	81	80	90	83	68	86	64	110	74	66	100	52	40	43
MCL		60	60	60	60	60	60	60	60	60	60	60	60	60	60	60	60	60	60

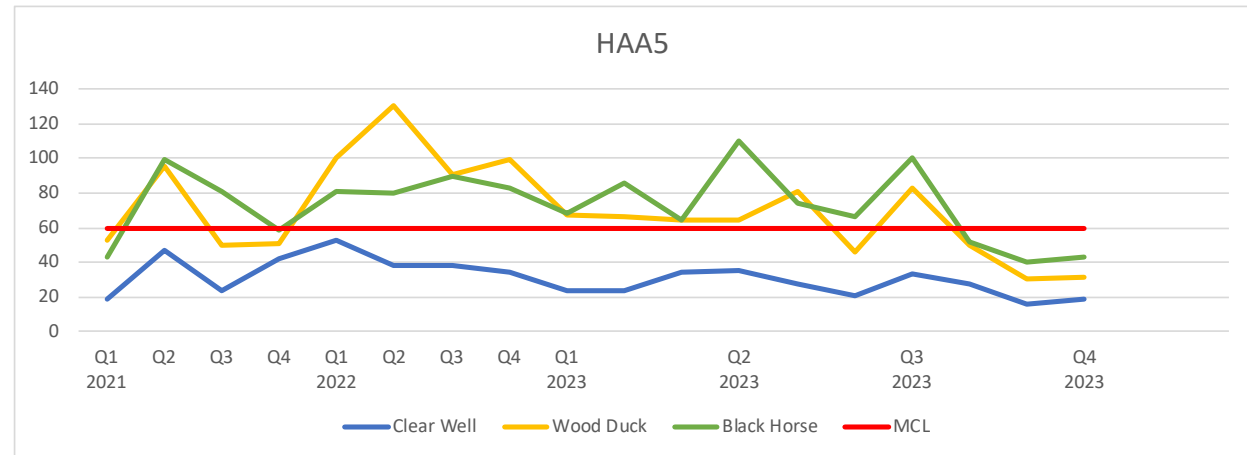

Operations and project updates

The Operations staff has made no operational changes to the water treatment process since last month's report. Replacement Carbon tanks for the GAC system were installed, backwashed according to manufacturer's specifications, and put into service this past Monday (11/13/23). Additional improvements in the planning phases include but are not limited to chemical injection refinement and safety entailing continuing upgrades to all

chemical injection stations and fully integrating them into the PLC programming. This will enhance the Operator's ability to adjust chemical feed rates and obtain immediate feedback from those adjustments.

For the ongoing GAC study, we took initial samples at startup of the new vessels for UVA/UVT and TOC (11/13/23), both upstream and downstream of the vessels. We will continue to take UVA/UVT readings weekly and TOC samples monthly (with DBP sampling). This information allows us track the efficacy of the GAC and gather more data for determining the expected life cycle of the GAC. Future operational costs for the use of GAC will be determined largely by the life expectancy of the GAC.

Fiscal Implications

The 5-year Capital Improvement Plan approved by your Board includes spending a total of \$1,000,000 for a DBP project(s) through Fiscal Year End 2027. The current year budget includes \$325,000 for a DBP project(s), as well as \$50,000 for the design phase of Vertical Intake No. 2.

File: OPERATIONS_DBP

HERITAGE RANCH COMMUNITY SERVICES DISTRICT

General Manager Report For the Month of November 2023

In addition to normal administrative, engineering, and operations duties, below are points for several areas of work:

Administration

- The General Manager met with the HROA General Manager in the field to look at the failed culvert on Heritage Road. A letter was also sent to HROA formally informing them of the urgency of the issue and potentially liability for District infrastructure.
- The October meeting of the MCWRA Reservoir Operations Committee was held in the District Board Room.
- The General Manager and Office Supervisor attended the Quarterly meeting of the CSDA SLO Chapter. The General Manager also attended the November meeting of the CSDA SLO Chapter Managers.
- The General Manager attended the November meeting of the Water Resource Advisory Committee.

Solid Waste

- The General Manager attended the November meeting of the IWMA Local Task Force.
- The SLO County Board of Supervisors approved re-joining SLO County Integrated Waste Management Authority (IWMA). In 2022 the County left IWMA, which is formed under a Joint Powers Authority or JPA. IWMA is working on updating the JPA again to add the County back. Additional updates will be reported as they become available.

Development

- There is nothing significant to report.

Reservoir Status

- As reported by Monterey County Water Resources Agency (MCWRA), as of November 6, 2023 the reservoir was at approximately 766.85 feet in elevation,

57% of capacity, or 214,135-acre feet of storage. MCWRA water releases were shown as 60 cfs.

